

Survey on IoT based Monitoring System for Advertising Board

Mayur Karale¹, Suraj Bhosale², Nikhil Gosavi³, Satish Birajdar⁴, Satish Yedde⁵

¹⁻⁴Student, Computer Engineering, K. J. College of Engineering and Management Research, Pune

⁵Guide, Computer Engineering, K. J. College of Engineering and Management Research, Pune

Abstract - With the increase of enormous outdoor advertising boards, the problems of public safety raised by the collapse of out of doors advertising boards have attracted great public concern. During this paper, a wireless sensor network (WSN) monitoring system is intended for the structural health monitoring (SHM) of enormous outdoor advertising boards. By using WSN technology, this method can judge the safety of the outdoor advertising boards and provides early warnings when the boards are being at risk. The monitoring system consists of two subsystems, one is that the WSN structure system supported Zig-Bee wireless sensor nodes with a 6-axis MEMS motion sensor integrated to capture the movement information, and therefore the other is that the monitoring center system controlled by ARM microcontroller for processing and long-distance wireless communications with a foreign server through a GPRS module. The simulation model of the outdoor advertising board is additionally built to research the deformed shape of the advertising board structure under wind load, and also the early warning judgment standard is proposed. The performance of the monitoring system is evaluated through several experiments under the condition of a laboratory in several aspects of the comparison experiments. With the rise of enormous outdoor advertising boards, the problems of public safety raised by the collapse of outside advertising boards have attracted great public concern. During this paper, a wireless sensor network (WSN) monitoring system is meant for the structural health monitoring (SHM) of enormous outdoor advertising boards. By using WSN technology, this technique can judge the safety of the outdoor advertising boards and provides early warnings when the boards are being in peril. The monitoring system consists of two subsystems, one is that the WSN structure system supported Zig-Bee wireless sensor nodes with a 6-axis MEMS motion sensor integrated to capture the movement information, and therefore the other is that the monitoring center system controlled by ARM microcontroller for processing and long-distance wireless communications with a foreign server through a GPRS module. The simulation model of the outdoor advertising board is additionally built to research the deformed shape of the advertising board structure under wind load, and therefore the early warning judgment standard is proposed. The performance of the monitoring system is evaluated through several experiments under the condition of a laboratory in several aspects of the comparison experiments.

Keywords: Software-Defined Networking, Internet of Things, Quality-of-Service, Routing.

1. INTRODUCTION

Now a day, large outdoor advertising boards are widespread within the prosperous area of a city, or along the most road and also the highway. These outdoor advertising boards are at risk of tilt or maybe collapse as time goes on because of their large size and long exposure within the complex outdoor environment (such as heavy rain, strong wind, earthquake, and other factors), thereby posing a heavy threat to the general public safety. Therefore, the relevant departments have to be compelled to track, in real-time, the condition of out of doors advertising boards. However, at the present, monitoring outdoor advertising boards mainly relies on the common manual inspection and video surveillance administered by the relevant government departments. It's evident that the lean risk can't be effectively identified at the sooner stage only by these visual inspections and straightforward physical measurements.

Now a Days, large outdoor advertising boards are widespread within the prosperous area of a city, or along the most road and also the highway. These outdoor advertising boards are at risk of tilt or perhaps collapse as time goes on because of their large size and long exposure within the complex outdoor environment (such as heavy rain, strong wind, earthquake, and other factors), thereby posing a significant threat to the general public safety.

2. LITERATURE SURVEY

Title: A USB-Enabled System-On-Chip Solution for 2.4-GHz IEEE 802.15.4 and ZigBee Applications.

Author: CC253x/4x User's Guide (Rev. D)

Description: The CC2531 is a USB enabled true system-on-chip (SoC) solution for IEEE 802.15.4, ZigBee, and RF4CE applications. It enables USB dongles or USB upgradable network nodes to be built with low total bill-of-material costs. The CC2531 combines the performance of a leading RF transceiver with an industry-standard enhanced 8051 MCU, in-system programmable flash memory, 8-KB RAM, and many other powerful features. □

Title: A fully compliant ZigBee 3.x solution: Z-Stack Z-STACK

Author: Texas

Description: Incorporates the uni_ed Zigbee Cluster Library which is at the foundation of dot-dot, the universal language

for IoT applications defining data objects, models and functionalities for embedded IoT applications Implements Zigbee Base Device Behavior specification, which defines a common set of mechanisms for network forming, discovering, and application provisioning to be used by all Zigbee devices Based on Zigbee PRO 2015 specification or later, it provides new and improved security modes, including Install Codes for out-of-band key exchange, and Distributed Security Networks for Coordinator-less network topology.

Title: Development of an Electronic Educational Kit with Android Application That Test Student Knowledge in Series and Parallel Resistor for Electrical Circuit (Res-Circuit Quiz Board)

Author: Mohd Firdaus Mohd Ab Halim, Nur Azmeen Iezzati Idrus, Amar Faiz Zainal Abidin, Siti Fatimah Sulaiman, Rozi Ri_n

Description: One of the important subjects in electrical Engineering course is the Electrical Circuit. The subject is known to be challenging as this is the first time student being exposed to the Electrical Engineering subject. To address this, this paper is proposing an educational board, named Res-Circuit Quiz Board. The educational board is designed to test students' knowledge in series and parallel resistor connection for subject Electrical Circuit. An android based application is designed as an interface for the quiz board to connect to through Bluetooth. The educational quiz board will give feedback to the student based on the circuit connection done by the student. The effectiveness of the educational quiz board is measured using a survey done to the target audience.

Title: Throughput of Customised ZigBee Stack- A Mathematical Modelling

Author: A.Narmada, P.Sudhakara Rao

Description: Research work is being done in the field of wireless communication protocols to find the desired applicability suitable to the end-user. ZigBee protocol is chosen due to its reliable, long-range, and robust communication. In this direction, there is a need for designing a common communication protocol to realize a virtual control network by customizing the existing Zig-Bee protocol stack. It is also required to embed internet support protocols in different layers of the proposed stack to enable the entire network with internet connectivity. The proposed application aims at interoperating different devices under user personal area network, this fact has led to propose a new protocol stack with which every device of the network can be easily operated or controlled with enhanced network capabilities like resource sharing, additional middle layer for realizing the proposed application using WPAN christened as ZigBee IP [ZI] stack.

3. Project Overview

In this system, we try to search out the condition of the board. During this system, we are using Arduino UNO and Wi-Fi Module to create it IoT. During this system, we also are using the Gyroscope Sensor to sense the change in angle. At the side of that, we also are able to find the condition of iron rod with the assistance of electrical Conductivity. We passing the electrical current through an iron rod, in order that depends on current conductivity we are able to measure either it's forged iron or Rust Iron. The simulation model of the outdoor advertising board is additionally built to investigate the deformed shape of the advertising board structure under wind load, and also the early warning judgment standard is proposed. The performance of the monitoring system is evaluated through several experiments under the condition of a laboratory in numerous aspects of the comparison experiments.

These outdoor advertising boards are at risk of tilt or perhaps collapse as time goes on because of their large size and long exposure within the complex outdoor environment (such as heavy rain, strong wind, earthquake, and other factors), thereby posing a significant threat to the general public safety. Therefore, the relevant departments got to track, in real-time, the condition of out of doors advertising boards. However, at this time, monitoring outdoor advertising boards mainly relies on the common manual inspection and video surveillance administered by the relevant government departments. It's evident that the lean risk cannot be effectively identified at the sooner stage only by these visual inspections and easy physical measurements.

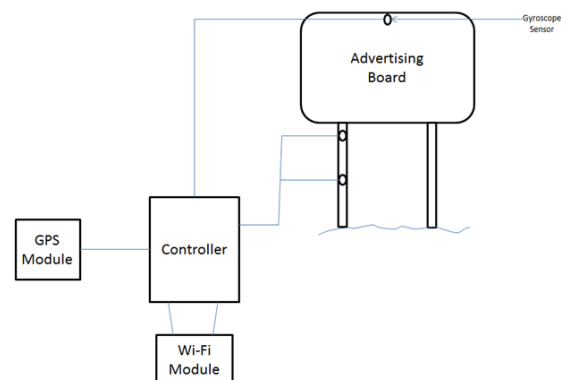

4. CONCLUSION

IoT Based monitoring system supported IoT and Gyroscope sensor for the big outdoor advertising boards is intended. Within the system, multiple 3-axis Gyroscope sensors are placed round the key load points on the massive outdoor advertising board, and that they all report back to one node called the coordinator. At each sensor node, an information fusion algorithm supported the measured data is employed to get an accurate and stable angle. The ZigBee network between the sensor nodes and coordinator allows the system to control with low power dissipation. Eventually,

the embedded monitoring platform judges the state of the boards and generates early warnings with the assistance of a predictive analytics algorithm.

5. REFERENCES

- [1] C CC253x System-on-Chip Solution for 2.4-GHz IEEE 802.15.4 and ZigBee Applications User's Guide. Available online: <http://www.ti.com.cn/cn/lit/ug/swru191f/swru191f.pdf> (accessed on 8 March 2017).
- [2] Stack Users Guide for SmartRF05EB and CC2530. Available online: <http://www.ti.com/tool/z-stackTechnical Documents> (accessed on 8 March 2017).
- [3] X. M. Wang, and J. H. Cheng, The causes analysis and countermeasure of billboard collapse under the strong wind load, *Construction Design for Engineering*, vol. 11, pp. 47-51, 2010.
- [4] Narmada, P. S. Rao, ZigBee based WSN with IP connectivity. in modeling and simulation, *Proc. Fourth International Conference on Computational Intelligence*, Sept. 2012, pp.178-181.
- [5] J. Ma, State-based time-series analysis and prediction, in *Proc. SNBP*, 2007, pp.227-232.
- [6] N. Sornin, M. Luis, T. Eirich, T. Kramp, and O. Hersent, *LoRaWAN Specification*. LoRa Alliance, 2016.
- [7] "Sigfox - The Global Communications Service Provider for the Internet of Things (IoT)." [Online]. Available: <https://www.sigfox.com/>
- [8] "Wi-SUN Alliance." [Online]. Available: <https://www.wi-sun.org/>
- [9] IEEE Standard for Local and metropolitan area networks- Part 15.4: Low-Rate Wireless Personal Area Networks (LR-WPANs) Amendment 3: Physical Layer (PHY) Specifications for Low-Data-Rate, Wireless, Smart Metering Utility Networks. IEEE Std 802.15.4g-2012 (Amendment to IEEE Std 802.15.4-2011), 2012.
- [10] IEEE Standard for Local and metropolitan area networks- Part 15.4: Low-Rate Wireless Personal Area Networks (LR-WPANs) Amendment 1: MAC sublayer. IEEE Std 802.15.4e-2012 (Amendment to IEEE Std 802.15.4-2011), 2012.
- [11] T. Winter, P. Thubert, A. Brandt, J. Hui, R. Kelsey, P. Levis, K. Pister, R. Struik, J. Vasseur, and R. Alexander, RPL: IPv6 routing protocol for low-power and lossy networks. *Internet Engineering Task Force (IETF)*, 2012.
- [12] IEEE Recommended Practice for Routing Packets in IEEE 802.15.4 Dynamically Changing Wireless Networks. IEEE Std 802.15.10-2017, 2017.
- [13] Y. Shoji, K. Nakauchi, and W. Liu, "Community-based wireless IoT infrastructure using ubiquitous vending machines," in *Proc. Cloudification of the Internet of Things (IoT)*, 2016.
- [14] W. Liu, K. Nakauchi, and Y. Shoji, "A location-aided flooding mechanism in community-based IoT networks," in *Proc. IEEE 7th Annu. Comput. Commun. Work. Conf. (CCWC)*, 2017.
- [15] Bluetooth SIG Proprietary, Specification of the Bluetooth System Covered Core Package Version 4.2, 2014. *mun.*, vol. 10, no. 5, pp. 1373-1377, May 2011.