

# Fabrication of Pedal Operated Multi Tools

Ankit Rajbhar<sup>1</sup>, Sudarshan Amudala<sup>2</sup>, Chandan Singh<sup>3</sup>, Deepak Gupta<sup>4</sup>, Ashish Patel<sup>5</sup>

<sup>1-4</sup>Department of Mechanical Engineering, Laxmi Institute of Technology, Sarigam

<sup>5</sup>Assistant Professor, Department of Mechanical Engineering, Laxmi Institute of Technology, Gujarat, India

\*\*\*

**Abstract** – Pedal operated multi tools machine is a machine which can be used for industrial application and household needs in which no specific input energy or power is needed. This project consist of crank and slider mechanism pedal is directly connected to the tools through crank and slider mechanism for the processing of cutting, grinding, and drilling of the wooden blocks, metal bars, PVC materials. The objective of the modal is using the conventional mechanical process which plays a vital role. The main aim is to reduce the human effort for machining various materials such as wooden blocks, steel, PVC etc.

This machine, which runs on human power works on the principle of the conversion of rotational motion to oscillatory motion. Importance of this project lies in the very fact that it is green project and helps us to reduce our electricity need. Secondary, this cutter can be used and transferred to our working place easily. Moreover, if we want we can generate electricity with our project by connecting it to dynamo, diode and battery.

**Key Words:** Pedal, Cutting, Grinding, Drilling, Multi Operations

## 1. INTRODUCTION

Industries are basically meant for Production of useful goods and services at low production cost, machinery cost and low inventory cost. Today in this world every task have been made quicker and fast due to technology advancement but this advancement also demands huge Investments and expenditure, every industry desires to make high productivity rate maintaining the quality and standard of the product at low average cost In an industry a considerable portion of investment is being made for machinery installation. So in this project we have a proposed a machine which can perform operations like drilling, cutting, grinding, some operations at different working centers simultaneously which implies that industrialist have not to pay for machine performing above tasks individually for operating operation simultaneously. According to some economists, manufacturing is a wealth-producing sector of an economy, whereas a service sector tends to be wealth-consuming. Emerging technologies have provided some new growth in advanced manufacturing employment opportunities in the Manufacturing Belt in India. A multipurpose machining is a machine to carry out multiple machining operations under single machine. This can be done by using a motor which can drive various tool bits that are used and designed to perform operations of drilling, slotting, sawing, chamfering and

countersinking. This will not only compact in size. The tediousness of using separate machines for various operations can be swapped by a user-friendly multipurpose machine which can perform all operations mentioned above under a single unit. The cost associated in buying the individual machines which can perform only one operation per will be no more. Apart from these most machines cannot perform the mentioned operation simultaneously.

## 2. WORKING PRINCIPLES

There are only two major principles on which our proposed machine generally works.

### 2.1 Scotch – Yoke Mechanism

Its convert rotary motion to reciprocating motion of hacksaw which is used for cutting operation.

### Scotch yoke mechanism

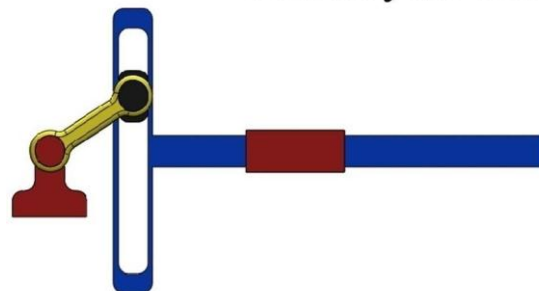

Fig-1: Scotch Yoke Mechanism

### 2.2 Slider Crank Mechanism

Power transmission through V-belt and pulleys. Its transmit power through the V-belt and pulley to the drilling and grinding attachments.

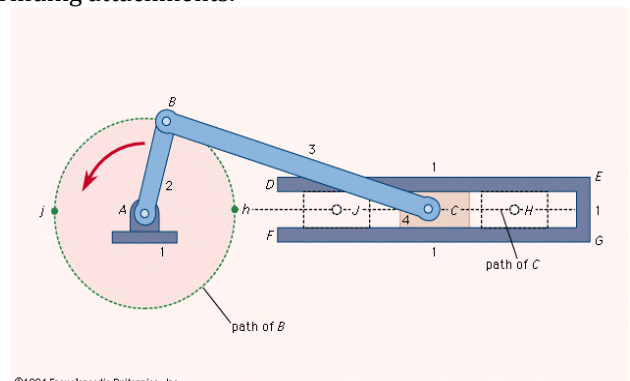

Fig-2: Slider Crank Mechanism

### 3. METHODOLOGY

In the present scenario most of machines are electrically driven to increase the productivity and reduce the manpower but in the rural area electricity is irregular or insufficient. Therefore we make human powered machine which can use in rural area and also in urban area to reduce the cost and to increase manpower utilization. Today in the industries production have been made very quicker and fast because of a new technology but this technology also demand a high investments. Our human powered machine is cheap that's why it reduce a cost of production. Electrically driven machines are mostly heavy weighted because of this it cannot be used for a mobile use. This automation is also become a cause of a worker's weaker health. Pedal operated machine also increase human health by a pedalling process its work as an exercise. Mostly electrically driven machines are single purpose machines. That's why it increase a machine equipment cost. Our multipurpose machine can be used for a more than one operations simultaneously on a same platform.

### 4. OBJECTIVES

- 1) The main objectives is to provide multi-operational machine which can also operate when electricity is not available. To provide a machine which can do more than one operation simultaneously.
- 2) To perform the drilling and grinding operation through pedaling.
- 3) To develop machine which will provide full utilization of manpower and also reduce worker health issue.
- 4) To make the machining operation cost-effective and eco-friendly.

### 5. ADVANTAGES

- 1) This pedal operated multi-purpose machine is fully manually operated that's why it can usable at a rural area. Less investment is required.
- 2) Reduce a worker health problem. Reduce an inventory and production cost.
- 3) It can be used for mobile application.
- 4) It is cheap as compared to all other electric operated machines.

### 6. DISADVANTAGES

- 1) This machine is not fit for mass production.
- 2) This machine is more time consuming as compared to electrical driven machines.

### 7. APPLICATIONS

- 1) This machine will be used in rural area, because of irregular electricity supply.
- 2) Reduce worker health issue.
- 3) For domestic Purpose.
- 4) To drill in a U-tube, wood and to grind mild steel, stainless steel etc.

### 8. FUTURE IMPLEMENTATION

- 1) We feel the project that we have done has a good future scope in any domestic purposes. The main constraint of this machine is the low initial cost and has low operating costs.
- 2) Savings resulting from the use of this device will make it pay for itself with in short period of time & it can be a great companion in any processing units.
- 3) The device affords plenty of scope for modifications, further improvements & operational efficiency, which should make it commercially available & attractive. If taken up for commercial production and marketed properly, we are sure it will be accepted to all. There are plenty of scopes if the machine is improvised as explained in the further improvisation concept.

### 9. CONCLUSIONS

We can see that all the production based industries wanted low production cost and high work rate which is possible through the utilization of multi-function operating machine. It requires less power as well as less time, since this machine provides working at different center it really reduced the time consumption up to appreciable limit. In an industry a considerable portion of investment is being made for machinery installation. So in this paper we have proposed a machine which can perform operations like drilling, cutting, grinding at different working centers simultaneously which implies that industrialist have not to pay for machine performing above tasks individually, since this machine will perform different operation simultaneously This machine can be used in remote places where electricity is irregular or insufficient. It can be used for light duty cutting and drilling operations of plywood also the grinding operation can be used to sharp the tools edges as well as to remove extra materials. Its working can be done in less floor space. Unskilled Labour can also handle it efficiently because of this we can reduce the cost of production which is the most important factor in production industry.

## ACKNOWLEDGEMENT

We would here by to take the opportunity to thank our institute for making us capable to take this project. We have undertaken this project under the guidance of a faculty member of our department. So we are very thankful to our guide **Mr. ASHISH PATEL**, in **Laxmi Institute of Technology** for their valuable guidance. He is the person who helped us in preparing the project with his best knowledge. We are also thankful to the college library staff for providing us the required reference books which helped us in preparing this project.

We would like to thank our HOD, **Mr. PARIKSHIT PATEL** for giving us the opportunity to take this project.

## REFERENCES

- [1] Dharwa Chaithanya Kirthikumar, "A Research on Multi Purpose Machine", International Journal for Technological Research in Engineering (Vol.1, Issue.1, ISSN:2347-4718) (2013).
- [2] S.G.Bahaley,Dr.A.U.Awate,S.V.Saharkar, "Performance Analysis of Pedal Powered Multipurpose Machine", International Journal of Engineering Research and Development (IJERD) (Vol.1, Issue.5,e-ISSN:2278-0181) (2012).
- [3] Linxu, Weinan Bai, Jingyu Ru,Qiang Li, "Design and Implementaion of the Reciprocating Pedal Powered Electricity Generating Device", Advanced Materials Research (Vol.282-283 (2011) pp 735-738.
- [4] Heinrich Arnold1 "The recent history of the machine tool industry and the effects of technological change "University of Munich, Institute for Innovation Research and Technology Management, November 2001.
- [5] Dr. Toshimichi Moriwaki "Trends in Recent Machine Tool Technologies" Professor Department of Mechanical Engineering Kobe University ,NTN Technical Review No.74(2006).
- [6] T. Moriwaki "Multi-functional machine tool" ,Department of Industrial and Systems Engineering, Setsunan University, Neyagawa, Japan CIRP Annals – Manufacturing Technology DOI:10.1016/j.cirp.2008.09.004 .
- [7] Frankfurt am Main "Multi-purpose machines ensure enhanced ", 1 January 11.
- [8] "Selecting and Planning the Process of Manufacture: Dr. Pulak M.Pandey <http://paniit.iitd.ac.in/~pmpandey>