

# Heating and Cooling Analysis of Workshop using CFD Simulation

Sweta Sharma<sup>1</sup>, Aniket Agrawal<sup>2</sup> Rahul Sahu<sup>3</sup>

<sup>1,2</sup> Mechanical Engineering Graduate, Government Engineering College Raipur, Chhattisgarh, India

<sup>3</sup> Assistant Professor, Department of Mechanical Engineering, Government Engineering College Raipur, Chhattisgarh, India

\*\*\*

**Abstract** - In this paper, the flow pattern of air currents and its influence in the temperature distribution is studied by the means of 3-Dimensional Computational Fluid Dynamics (CFD) model of a Workshop. Beginning with 3D model designing and simulation, the analysis is done in FLUENT and applying  $k-\epsilon$  turbulence model. The analysis is done by taking into consideration different situation like an open system analysis with all windows and a door open and a closed system analysis of the workshop with all openings closed, having a fan mounting that induces a turbulent air current. The velocity-pressure contour and other important parameters such as temperature, density variations etc. were also been plotted. The simulations were performed in steady state conditions. A simulation has also been performed with the change in ceiling material i.e. using a gypsum board as a ceiling material, instead of asbestos sheets (material which is usually used as a ceiling of a workshop building) for the heat reduction inside the room. On comparing, the results by the three simulation shows that using gypsum as a false ceiling material would reduce more outside heat and temperature accumulation inside the workshop, making it a comfort place to work for the staff and students. This would also reduce the dependence on artificial resources for comfort living.

**Key Words:** Reynold's number, Simulation, Asbestos sheet, Gypsum Board, Rayleigh number, Prandtl number.

## 1. INTRODUCTION

It is necessary to provide buildings with adequate ventilation to ensure both removal of stale air and the supply of fresh air for occupants. This can be provided in different ways, which include: mechanical ventilation, in which fans and ducts are used to move large volumes of air with or without heating the air; air-conditioning, in which the temperature and humidity of air, supplied via fans and ducts, is fully controlled; and natural ventilation which harnesses the naturally occurring driving forces of wind and buoyancy. It is also possible to use a hybrid approach which uses both natural forces and mechanical means (usually fans). These are known as mixed mode systems.

### 1.1 Background

Natural ventilation is effective in improving air quality, thermal comfort, and reducing energy consumption when utilized properly. Two principles that are important when

Designing buildings for natural ventilation are thermal comfort and air quality. Recommendations for thermal comfort and maximum air velocities are prescribed in the ASHRAE standard 55. Thermal comfort is determined from conditions where 80% of the occupants find the environment acceptable.

Moving air leads to an increase in the acceptable temperature. The thermal conditions and corresponding temperatures increase with air speed, and are summarized in Table 1.1 and Table 1.2. The upper limit of air speed for light activity is approximately 0.9 m/s (~1m/s).

**Table -1.1:** Thermal comfort conditions from ASHRAE Standard 55.

Outdoor Air Temperature	10° C		33.5° C	
	LOWER LIMIT	UPPER LIMIT	LOWER LIMIT	UPPER LIMIT
90% acceptable	17.5°	23.5°	23°	30.5°
80% acceptable	18.5°	24.5°	26°	31°

**Table -1.2:** Increase in acceptable temperature due to moving air.

Air Speed (m/s)	Temperature Increase (° C)
0.6	1.2
0.9	1.8
1.2	2.2

### 1.2 Gypsum Board

Gases have poor thermal conduction properties as compared to liquids and solids, and so they can be used as a great insulation if they can be trapped. In order to further augment the effectiveness of a gas (such as air), it can be disrupted into small cells which effectively cannot transfer heat by natural convection. **Gypsum or Drywall** is a panel of calcium sulphate dehydrate with or without additives,

used in the construction of walls and ceilings. The plaster is mixed with fibre typically paper, fibreglass, asbestos plasticizer, foaming agent and various additives. Gypsum boards have a number of outstanding advantages:

- Fire resisting
- Sound Attenuation
- Durable
- Economical



Fig - 1: Gypsum board

Manufacturers promote renewable energy sources, support technological research and development efforts, and educate employees as well as their communities on the importance of a responsible and holistic approach to the built and natural environments.

Table -1.3: Thermal properties of Gypsum Board

S. No.	THERMAL PROPERTIES	NUMERICAL RANGE
1.	Density of matrix	2000-2100 kg/m <sup>3</sup>
2.	Thermal Conductivity	0.336-0.400 W/m-K
3.	Volumetric heat capacity	(0.145*10 <sup>6</sup> )-(0.150*10 <sup>6</sup> )-m <sup>3</sup> /K
4.	Young's Modulus	2000N/mm <sup>2</sup>
5.	Compressive Strength	2.5-3N/mm

In the 1840s, physician and inventor Dr. John Gorrie [1] of Florida proposed the idea of cooling cities to relieve residents of "the evils of high temperatures" Gorrie believed that cooling was the key to avoiding diseases like malaria and making patients more comfortable. Study of indoor air is of interest because we spend a large amount of our time indoors. Chen [2009] and Chen et al. [2] [2010] presented several tools that are used to predict ventilation performance in buildings, such as analytical models, empirical models, small scale experimental models, full-

scale experimental models, multi zone network models, zonal models, and CFD models.

Chow et al. [3] [1996] demonstrated the application of CFD in building services engineering, and illustrated different systems such as fire engineering, prediction of smoke movement in large enclosures, sprinkler and hot air interaction, combustion with a simple chemical reaction system approach, HVAC design and air-conditioned gymnasiums and offices. Fletcher et al. [3] [2001] did a similar type of study and showed the importance of CFD as a building services engineering tool. In their work, different examples showing applications of CFD were presented, including contamination and thermal comfort in a room, pollution control in a car park, natural ventilation and thermal comfort with solar heating, the heat-stacking effect etc. Zhai [3] [2006] showed various applications of CFD in building design such as in site planning, ventilation, and pollution dispersion and control. Norton and Sun [4] [2006] gave a detailed review on the use of CFD as a design and analysis tool for the food industry. Lee et al. [5], Posner et al. [6][2003] and Khan et al. [7][2006] did CFD simulations to study the effects of inlet and exhaust locations and gas densities on contaminant concentrations.

Bulińska et al. [8] [2014] performed CFD simulations in a room with one sleeping person to find the measuring area of mean CO<sub>2</sub> concentration. Rojas et al. [9] [2015] studied the mixing of living room air and bedroom air while using supply air nozzles only in bedrooms. Gilani et al. [10] [2016] did sensitivity analysis for CFD simulations of a test room using different grid sizes, turbulence models, discretization schemes and convergence criteria. Ning et al. [11] [2016] used CFD to simulate airflow field, mean age of air and CO<sub>2</sub> distributions inside a bedroom using different heights of conditioned air supply outlet. Thus, several papers are available in the literature showing different applications of CFD modeling in indoor environments.

## 2. FUNDAMENTAL PRINCIPLES

### 2.1 Fundamental Principle behind Natural Ventilation

A major force behind natural ventilation is buoyancy. Buoyancy is driven by a temperature difference between the indoor and outdoor density difference. When buoyancy is the dominant force, the flows will have an upward flow, as hot air moves upward and cold air replaces it underneath. When the temperature difference is smaller, leading to a reduced buoyancy force, the flow is downward, as air moves from top to bottom. Once there is a negligible temperature difference, the stack pressure is reduced to near zero and buoyancy effects are less pronounced.

Buoyancy effects are determined by the ratio of buoyancy forces to viscous forces, known as the Grashof (Gr) number:

$$Gr = \frac{g \beta \Delta T l^3}{\nu^2}$$

where  $g$  is gravity,  $\beta$  is the thermal expansion coefficient,  $\Delta T$  is a temperature difference,  $l$  is a length scale, and  $\nu$  is the kinematic viscosity. Transition to turbulent flow approximately occurs when the Rayleigh (Ra) number is  $Ra = 10^9$ :

$$Ra = Gr \cdot Pr$$

where  $Pr$  is the Prandtl (Pr) number:

$$Pr = \frac{\nu}{\alpha}$$

$\alpha$  is the thermal diffusivity.

Wind-driven flow is due to a pressure difference between the openings. In cross-ventilation, the pressure difference is often created by wind on the windward side. The flow creates a higher pressure on the windward side of the building and a lower pressure on the leeward side, driving flow from windward to leeward. Other driving forces in wind-driven flow are turbulence effects and the opening size. The effect of wind-driven flow is measured using the Reynolds (Re) number:

$$Re = \frac{\rho V L}{\mu}$$

where  $\rho$  is the density,  $V$  is a velocity, and  $\mu$  is the fluid dynamic viscosity.

Most flows have a combination of buoyant forces and wind driven forces. The relationship  $Gr/Re^2$  is used to determine the dominant effect.

## 2.2 Turbulence Modeling Theory

The presence of the Closure Problem in turbulent flow poses an intractable problem. In an effort to meet the overwhelming need for computational results of turbulent flows, turbulence models were developed. Turbulence models consist of a set of several equations which, when solved in conjunction with the proper forms of the momentum and continuity equations, approximate the behavior of the Reynolds stresses. Numerous models have been introduced through the years, with varying degrees of success. The success of a model is determined by the following three criteria:

**Accuracy** - The model must be capable of providing solutions which are within tolerable bounds of accepted experimental results and the basic governing equations of fluid dynamics.

**Generality** - The model must be capable of being implemented into a wide variety of flow conditions and geometry without requiring significant changes.

**Easily Implemented** - Although computational capabilities have significantly increased, overly-complex models may

increase the required computational time beyond the limits of feasibility.

Turbulence models are divided into the following classes, based on the number of additional partial-differential equations which must be solved:

**Zero Equation Model** - The turbulence is described through the use of algebraic equations. Thus, the only partial differential equations requiring solution are the mean flow continuity and momentum equations.

**One Equation Model** - A partial-differential equation for the turbulent velocity scale is solved in addition to the mean flow partial-differential equations.

**Two Equation Model** - Two partial-differential equations for the turbulent velocity scales are solved in addition to the mean flow equations.

Although there are numerous models which may be employed, this study makes use of a two-equation model.

## 2.3 k-ε Turbulence Model:-

K-epsilon(k-ε) turbulence model is the most common model used in CFD to simulate mean flow characteristics for turbulent flow conditions. It is a two equation model that gives a general description of turbulence by means of two transport equations (PDEs). The original impetus for the K-epsilon model was to improve the mixing-length model, as well as to find an alternative to algebraically prescribing turbulent length scales in moderate to high complexity flows.

The first transported variable is the turbulence kinetic energy (k).

The second transported variable is the rate of dissipation of turbulence energy (ε).

## 2.4 Justification for k-ε Use:-

While detailed derivations of other turbulence models are not included, the justification for the use of the k-ε model should be addressed.

Because the k-ε model is a two-equation model, improved accuracy is obtained in comparison to less-complicated models. Researchers investigating some of the primary two-equation models have discovered that only the k-ε model yields experimentally substantiated results for regions far from solid boundaries or walls [Launder, 1974; Launder, et al., 1972][14]. For the other models to match the results, it was found necessary to replace some of the constants with empirical functions which added to the complexity of the models.

### 3. METHODOLOGY

#### 3.1 Geometric Modeling

Geometrical arrangement used in the experiment is presented, where  $H = 7.62\text{m}$  (height in meters). The inlet velocity distribution was a uniform velocity profile with a magnitude of  $3.53\text{ m/s}$ . Numerical computations were performed software package Fluent developed by ANSYS [15].

#### 3.2 CFD Meshing

The whole computational domain has to be divided into small control volumes, called grid cells in order to solve the discretized transport equations.

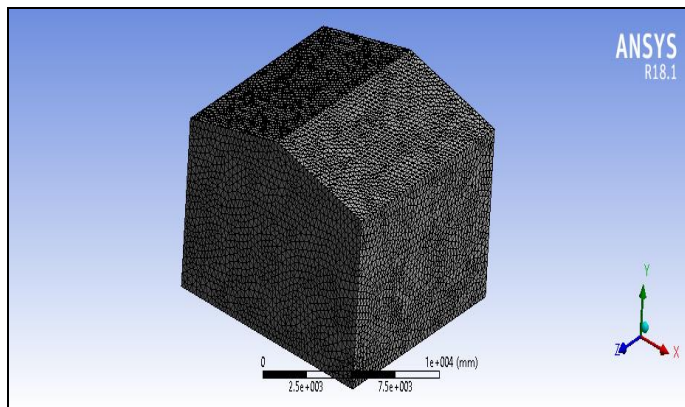

Fig - 3.2: Meshed model of Workshop

### 4. RESULT AND DISCUSSION

CFD problems are defined in terms of boundary conditions, and it is important to specify them correctly. The material that initially fills the entire solution domain was selected as the air at  $23^\circ\text{C}$ ,  $1\text{atm}$  and treated as incompressible fluid.

#### CASE 1: Natural Ventilation Analysis through windows and door

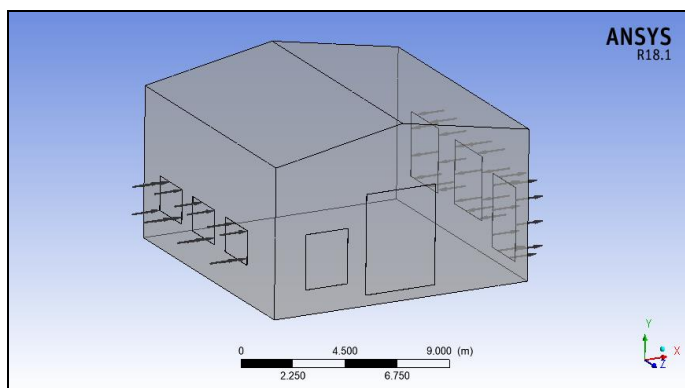

Fig - 4.1: Boundary Conditions

#### Analysis Details

Inlet boundary condition : Window

Outlet Boundary condition : Door

Reference Pressure :  $1\text{ atm}$

Turbulence Model : k-epsilon

Material : Air

Inlet air speed :  $3.53\text{ m/sec}$

Temperature :  $300\text{K}$

Turbulence Intensity : Medium

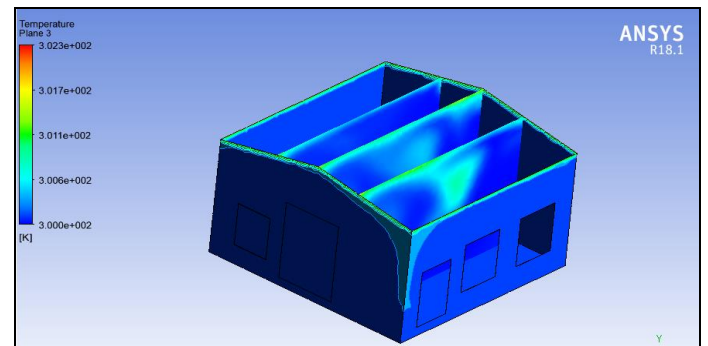

Fig. 4.2: Temperature Plot at different location using plane geometry plot

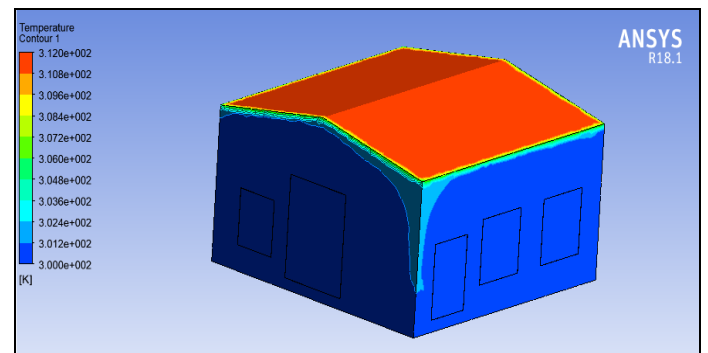

Fig. 4.3: Temperature plot from outer boundary including roof with temperature  $312\text{K}$

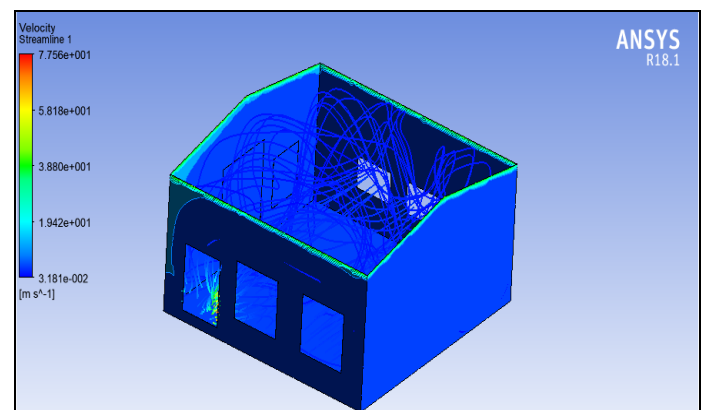
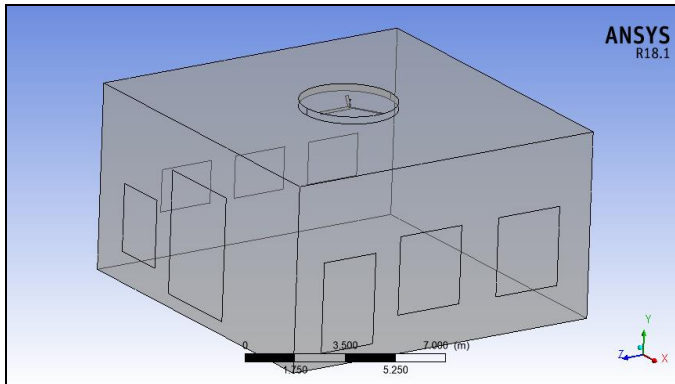

Fig. 4.4: Streamlines Plot

**CASE 2: Forced Air Model Analysis using Ceiling fan (CLOSED SYSTEM)**

**CASE 3: Forced Air Model Analysis using Ceiling fan (OPEN SYSTEM)**



**Fig. 4.5: Boundary Condition**

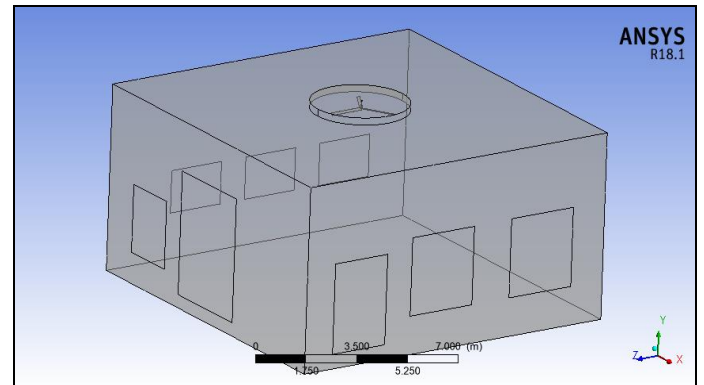

**Fig. 4.7: Boundary Condition**

**Analysis Details**

Inlet boundary condition : None(window closed)  
 Outlet Boundary condition : None (Door closed)  
 Reference Pressure : 1 atm  
 Turbulence Model : k-epsilon  
 Energy Model : Isothermal energy  
 Material : Air  
 Fan rotation speed : 80rev/sec  
 Ceiling Temperature : 312K  
 Room Temp initial : 300 K  
 Turbulence Intensity : Medium

**Analysis Details**

Inlet boundary condition : None(window open)  
 Outlet Boundary condition: None (Door open)  
 Reference Pressure : 1 atm  
 Turbulence Model : k-epsilon  
 Energy Model : Thermal energy  
 Material : Air  
 Fan rotation speed : 80rev/sec  
 Ceiling Temperature : 312K  
 Room Temp initial : 300 K  
 Turbulence Intensity : Medium

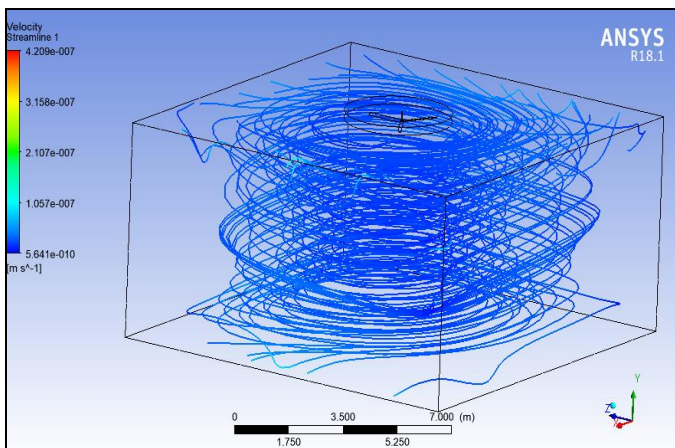

**Fig. 4.6: Velocity streamlines**

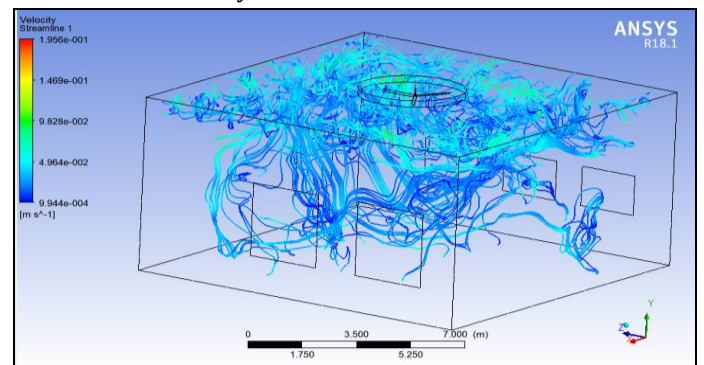

**Fig. 4.8: Velocity streamlines**

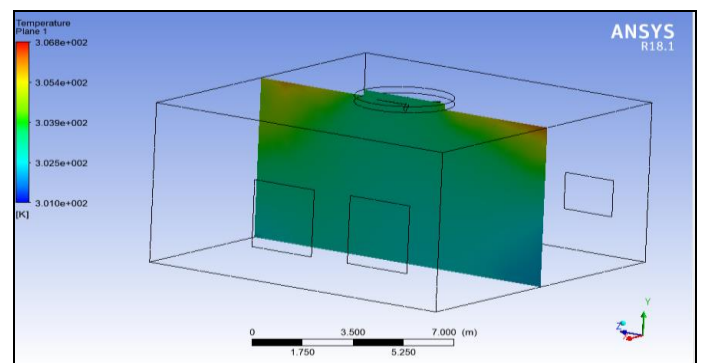

**Fig. 4.9: Temperature Plot**

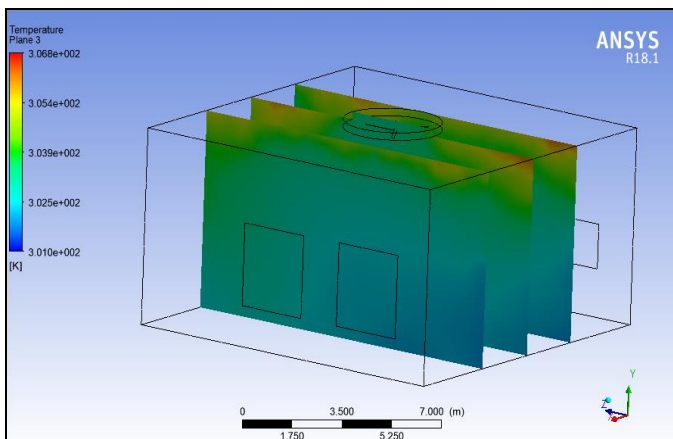

Fig. 4.10: Temperature plots

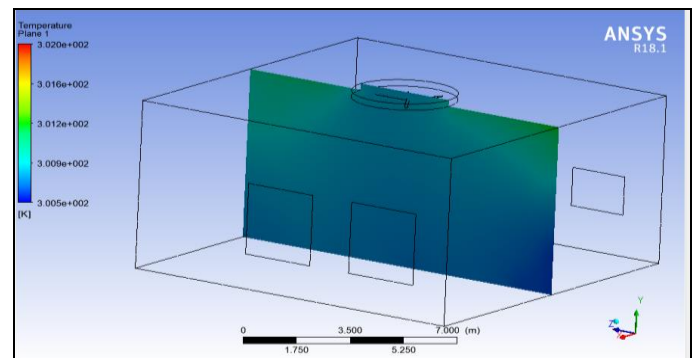

Fig. 4.13: Temperature plot on cross sectional plane

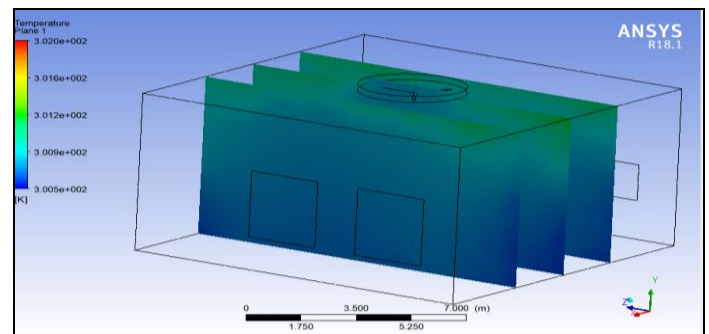

Fig. 4.14: Temperature plot on cross sectional planes

### CASE 4: Forced Air Model Analysis using false ceiling (Gypsum Board)

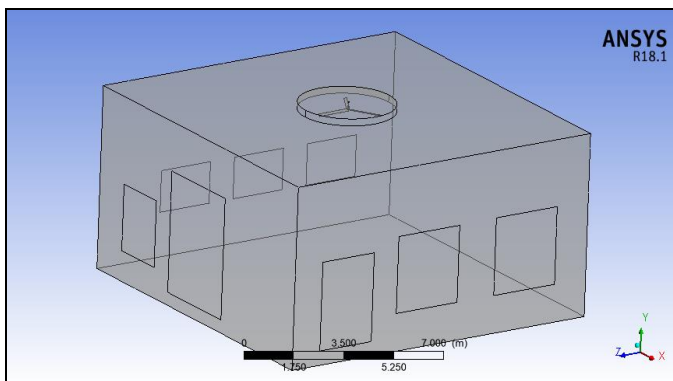

Fig. 4.11: Boundary Conditions

#### Analysis Details

Inlet boundary condition : None(window open)

Outlet Boundary condition: None (Door open)

Turbulence Model : k-epsilon

Material : Air

Fan rotation speed : 80rev/sec

Ceiling Temperature : 301K

Room Temp initial : 300 K

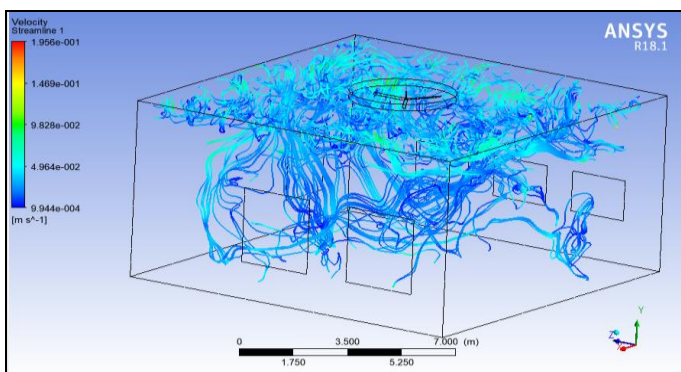

Fig. 4.12: Velocity streamlines

### 4.1 RESULT

On comparing the CFD simulation and the experiment data, we observe that there is a reduction of temperature inside the room by 6-8°C.

On using Gypsum Board as a false ceiling materials, we observe a temperature reduction from 3-4°C during a regular daytime.

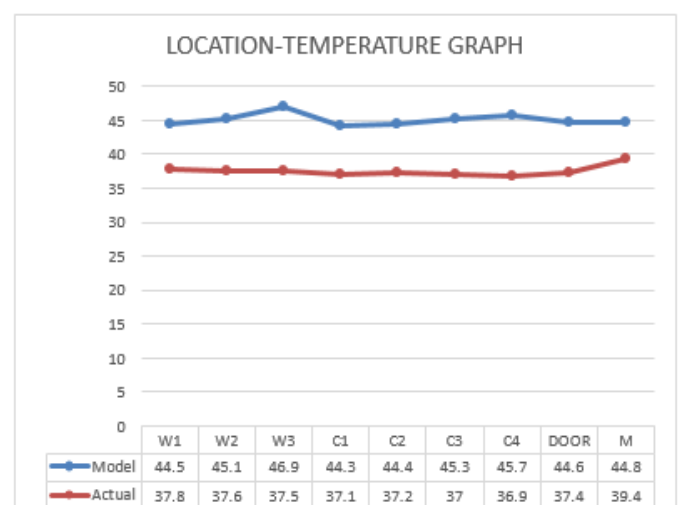

Fig. 4.15: Graph showing use of Gypsum Board

This graph is drawn with the location-temperature in the X-Y axis respectively. The abbreviations W, C and M denotes Windows, Corners of the room and temperature at the

Middle of the room respectively. The upper line shows the temperature line drawn without any false ceiling material whereas the lower line shows the line drawn using Gypsum as a false ceiling.

## 5. CONCLUSIONS

This work presents CFD simulations with temperature plots, velocity streamlines and airflow pattern in a workshop. The CFD simulations were performed to study the mixing of the air coming from the supply inlets and also, defining the critical region of the workshop due to huge amount of heat carried during the day time. Several CFD simulations are carried out by considering different conditions and using three-dimensional, steady state, incompressible flow energy equations with k- $\epsilon$  turbulence model.

Lowering the ventilation temperature to the human thermal comfort zone is very important for a building to make it efficient for the people living in. To lower the convective heat transfer rate from ceiling is studied and found that Gypsum as a false ceiling materials will lower the inside temperature of the room by 6°- 8°C. This material not only cost at cheap rate but are easily available in sheets at any false ceiling dealer. Most importantly, these materials are environment-friendly. They neither lead any step towards emission of harmful product into our atmosphere nor towards global warming. Hence, with the growing demand of HVAC in our planet, these materials are proving to be more energy efficient and beneficial for our future generation.

## REFERENCES

- [1] Chevron Corporation. Annual Report. [Online] 2006. Available from: [http://www.chevron.com/documents/pdf/annual\\_report/Chevron2006AnnualReport\\_full.pdf](http://www.chevron.com/documents/pdf/annual_report/Chevron2006AnnualReport_full.pdf).
- [2] Srujal Shah & Kari Dufva. CFD Modeling of Airflow in A Kitchen Environment: Towards improving energy efficiency in buildings. South-Eastern Finland University of Applied Sciences Mikkeli 2017
- [3] Chen, J., Duffy, B., Fletcher, D.F., Haynes, D.F. and Nelson, P. 2001. FTIR spectroscopy measurements and CFD simulations of the pollutants arising from unflued combustion in a room. *Building and Environment* 36, 597–603
- [4] Norton, T. and Sun, D.-W. 2006. Computational fluid dynamics (CFD) – an effective and efficient design and analysis tool for the food industry: A review. *Trends in Food Science & Technology* 17, 600–620.
- [5] Lee, E., Feigley, C.E. and Khan, J. 2002. An investigation of air inlet velocity in simulating the dispersion of indoor contaminants via computational fluid dynamics. *The Annals of Occupational Hygiene* 46, 701–712.

- [6] Posner, J.D., Buchanan, C.R. and Dunn-Rankin, D. 2003. Measurement and prediction of indoor air flow in a model room. *Energy and Buildings* 35, 515–526.
- [7] Khan, J.A., Feigley, C.E., Lee, E., Ahmed, M.R. and Tamanna, S. 2006. Effects of inlet and exhaust locations and emitted gas density on indoor air contaminant concentrations. *Building and Environment* 41, 851–863.
- [8] Bulińska, A., Popiołek, Z. and Buliński, Z. 2014. Experimentally validated CFD analysis on sampling region determination of average indoor carbon dioxide concentration in occupied space. *Building and Environment* 72, 319–331.
- [9] Rojas, G., Pfluger, R. and Feist, W. 2015. Cascade ventilation–Air exchange efficiency in living rooms without separate supply air. *Energy and Buildings* 100, 27–33.
- [10] Gilani, S., Montazeri, H. and Blocken, B. 2016. CFD simulation of stratified indoor environment in displacement ventilation: Validation and sensitivity analysis. *Building and Environment* 95, 299–313.
- [11] Ning, M., Mengjie, S., Mingyin, C., Dongmei, P. and Shiming, D. 2016. Computational fluid dynamics (CFD) modelling of air flow field, mean age of air and CO<sub>2</sub> distributions inside a bedroom with different heights of conditioned air supply outlet. *Applied Energy* 164, 906–915.
- [12] Launder, B.E. and D.B. Spalding. (1974). *The Numerical Computation of Turbulent Flows. Computer Methods in Applied Mechanics and Engineering*. Vol. 3.
- [13] ANSYS, Inc. 2014. ANSYS® Fluent, Release 16.0, Theory Guide, ANSYS, Inc.

## BIOGRAPHIES



Sweta Sharma obtained her bachelor's degree (B.E.) from Govt. Engineering College Raipur. Her areas of interest are thermodynamics and Heat transfer.



Aniket Agrawal completed his UG in Mechanical Engineering from Govt. Engineering College Raipur and interest in Thermal Engineering.



Rahul Sahu, Assistant Professor obtained his Master's in Technology (M. Tech.) from Indian Institute of Technology Bombay in Thermal & Fluid Mechanics.