

Complete Holter Monitor

Sharvari M. Kallole¹, Rutuja R. Pujari², Kajal V.Aursange³

^{1,2}B. Tech Student

^{1,2} Department of Electronics and Telecommunication Engineering,
DKTE Society's Textile and Engineering Institute, Ichalkaranji, Maharashtra, India

Abstract – Cardiovascular disease is the first leading cause of global death. There are well understood early symptoms of cardiovascular disease that could be used to greatly help in saving many lives and minimizing damages by detecting and reporting at an early stage. A Holter monitor is one of the solutions on this problem. A Holter monitor is a type of ambulatory electrocardiography device, which is used to monitor electrical activity of the heart (ECG). In this proposed system, we continuously transmit and monitor ECG with heart rate and oxygen percent present in blood. Data is extracted from the modules and using SD card module data is stored in SD card. To make system real time, we can use wifi module to upload data on cloud. By monitoring at least 24 to 48 hours of this biomedical data doctor can diagnose disease much earlier. If patient feels abnormal and wants to check current data for that purpose LED display is used. The proposed system is compact, low cost and real time.

Key Words: Holter monitoring, Heart diseases, ECG signal, Pulse sensor, oled display.

1. INTRODUCTION

Health related issues have been regarded as one of the major problem which impact quality of life. Hence there are numerous application in this field where as patient's can see their own physiological measurements and doctors as well. Cardiovascular disease, such as heart attack, stroke, and hypertension, is caused by disorders of the heart and blood vessels. There are well understood early symptoms of cardiovascular disease that could be used to greatly help in saving many lives and minimizing damages by detecting and reporting at an early stage. Heart disease has some early signs like shortness of breath, rapid or irregular heartbeats. If patient's heart seems to skip a beat, race, or work a bit too slow, patient could have a condition known as arrhythmia. Focusing on these signs doctors might suggest patient to wear a device called a Holter monitor. A Holter monitor is a type of ambulatory electrocardiography device, a portable device for cardiac monitoring for at least 24 to 48 hours. The Holter's most common use is for monitoring ECG (electrocardiography) heart activity. The Holter monitor records electrical signals from the heart via a series of electrodes attached to the chest. So at beginning stage doctor can diagnose disease and patient will get proper treatment. But, the Holter monitor presently available in market has facility of only monitoring ECG. In this project, we added two more parameters which are important in diagnosis of

cardiovascular disease that is heart rate and oxygen percentage present in blood. Holter monitor don't give real time results. It may take one or two weeks. So, in this project we make the system real time. As well as, if patient want to see their current biomedical data, by using oled patient can see current biomedical data.

Objectives:

1. To make light in weight holter monitor
2. Acquisition of two important ECG signal, PULSE signal and concentration of oxygen using SPO2 module.

2. Block diagram:

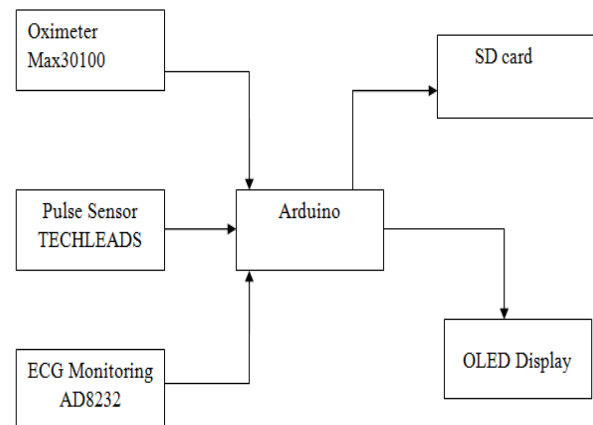

Fig -1: Block Diagram of complete holter monitor

Basically, patient may be asked to wear a holter monitor to check if the patient has slow, fast or irregular heartbeats. Considering not only heart but also the whole body for diagnosis, it may be easy to detect the abnormalities in patient's body. In proposed system, we are extracting ECG signal from AD8252 ECG module, Pulse signal from Techleads pulse sensor and oxygen concentration in blood by using (MAX 30100) SPO2 sensor module. These three components are used to acquire signal and given to arduino for further processing. All three signals are stored in SD card further it is given to doctor for diagnosis purpose and if patient wants to see their current reading so that the signals are displayed on OLED display.

3. Flow chart:

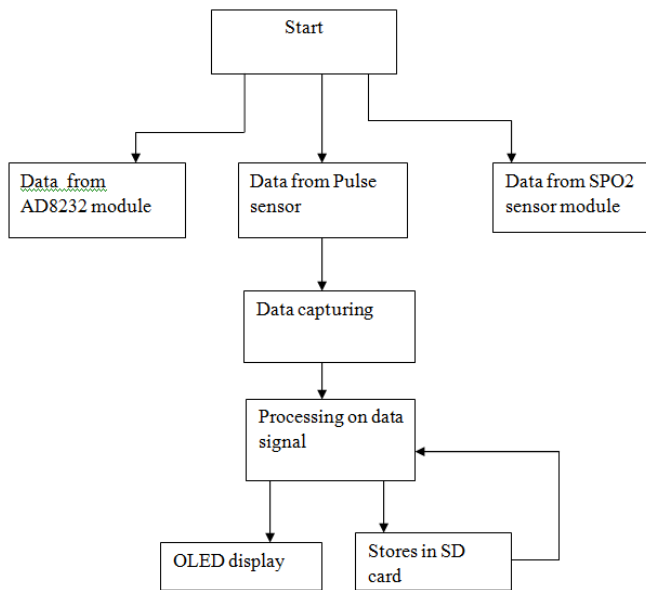

Fig -2: Flow chart of complete holter monitor

When the system gets started, biomedical data of patient's body is acquired using three sensors. This biomedical data is given to the microcontroller for processing. In microcontroller, we convert analog pulse signal to beats per minutes by using mathematical operations. This biomedical data is stored in SD card using SD card module and displayed on OLED display. We can send this data on IOT for real time access, so that doctor and family members can observe and record.

4. WORKING COMPONETS:

In this project, we are using three types of sensor modules which are pulse sensor, ECG AD8232 module and SPO2 MAX30100 sensor module. Also the microprocessor is Arduino UNO, OLED display and SD card module.

4.1 Arduino UNO:

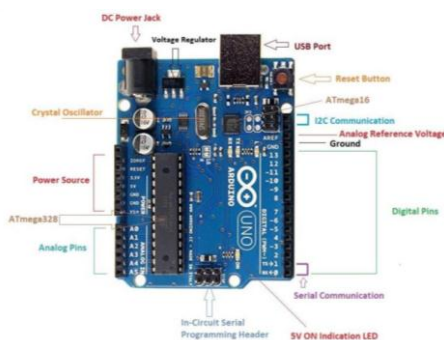

Fig -3: Arduino UNO

Arduino is an open-source electronics platform based on easy-to-use hardware and software. Arduino boards are able to read inputs - light on a sensor, a finger on a button, or a

Twitter message - and turn it into an output - activating a motor, turning on an LED, publishing something online. You can tell your board what to do by sending a set of instructions to the microcontroller on the board. To do so you use the Arduino programming language (based on Wiring), and the Arduino Software (IDE), based on Processing.

4.2 Pulse sensor:

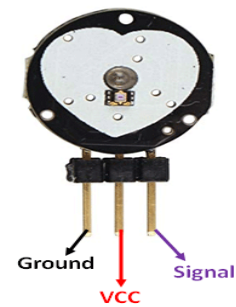

Fig -4: Heart rate sensor

Heart rate is a window into your muscles and lungs as it reveals how hard they are working. Heart rate can be measured in different ways. Two of the most common techniques are electrical and optical methods, the latter is more cost effective and convenient. In principle, the optical method (known as photoplethysmography) measures the heart rate by sensing changes in blood flow through the index finger. A plot for this change recorded against time is named as photoplethysmographic (PPG) waveform. The working of the Pulse/Heart beat sensor is very simple. The sensor has two sides, on one side the LED is placed along with an ambient light sensor and on the other side we have some circuitry. This circuitry is responsible for the amplification and noise cancellation work. The LED on the front side of the sensor is placed over a vein in our human body. This can either be your Finger tip or you ear tips, but it should be placed directly on top of a vein. Now the LED emits light which will fall on the vein directly. The veins will have blood flow inside them only when the heart is pumping, so if we monitor the flow of blood we can monitor the heart beats as well. If the flow of blood is detected then the ambient light sensor will pick up more light since they will be reflected by the blood, this minor change in received light is analyzed over time to determine our heart beats.

4.3 ECG AD8232 module:

The AD8232 Heart Rate Monitor breaks out nine connections from the IC. We traditionally call these connections "pins" because they come from the pins on the IC, but they are actually holes that you can solder wires or header pins to.



Fig -5: ECG AD8232 sensor module

The ECG Module AD8232 Heart ECG Monitoring Sensor Module kit for Arduino is designed to extract, amplify, and filter small bio-potential signals in the presence of noisy conditions; such as those created by motion or remote electrode placement.

Specifications:

1. Operating Voltage(VDC): 3.3V
2. Operating Temperature (°C): -40 to +90
3. Cable Length: 50 CM
4. Length (mm): 36, Width (mm): 30, Height (mm): 18
5. Weight (gm): 5
6. Designed to extract, amplify, and filter small biopotential signals.
7. Leads-Off Detection.
8. Shutdown Pin.

4.4 SPO2 MAX30100 pulse oximeter module:



Fig -6: MAX30100 sensor module

Pulse Oximeters are low cost non-Invasive medical sensors used to continuously measure the Oxygen saturation (SPO2) of hemoglobin in blood. It displays the percentage of blood that is loaded with oxygen. The principle of pulse oximetry is based on the differential absorption characteristics of oxygenated and the de-oxygenated hemoglobin. Oxygenated hemoglobin absorbs more infrared light and allows more red lights to pass through. Whereas deoxygenated hemoglobin absorbs more red light and allowing more infrared light to pass through. Each pulse oximeter sensor probe contains two light emitting diode one emitting red light and the other emitting near infrared light; it also has a photo-detector. The photo-detector measures the intensity of transmitted light at

each wavelength. And using the differences in the reading the blood oxygen content is calculated. The probe is placed on a suitable part of the body, usually a fingertip or ear lobe.

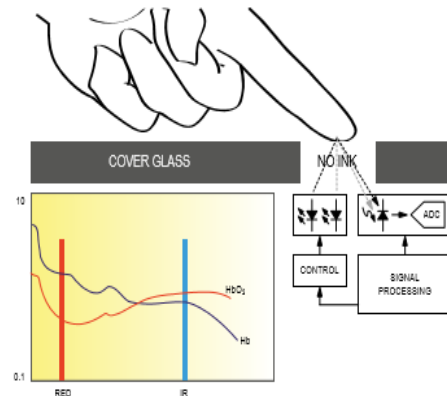

Fig -7: Internal structure of MAX30100

The MAX30100 is a complete pulse oximetry and heart rate sensor system solution designed for the demanding requirements of wearable devices. The MAX30100 is fully configurable through software registers, and the digital output data is stored in a 16-deep FIFO within the device. The FIFO allows the MAX30100 to be connected to a microcontroller or microprocessor on a shared bus, where the data is not being read continuously from the device's registers.

4.5 SD card module:

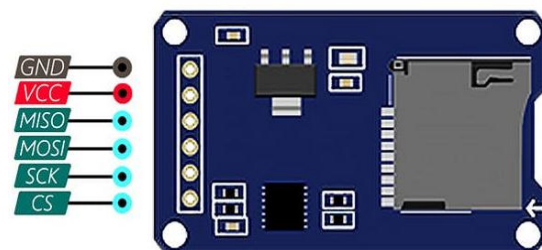

Fig -8: SD card module

This Micro SD Card is used for transferring data to and from a standard sd card. The pin out is directly compatible with Arduino and also can be used with other microcontrollers. It allows us to add mass storage and data logging to our project. The SD and micro SD card modules allow you to communicate with the memory card and write or read the information on them. The module interfaces in the SPI protocol.

Features:

1. Input Voltage: 3.3V/5V
2. With all SD SPI Pins out :MOSI, SCK, MISO and CS for further connection
3. Through programming, you can read and write to the SD card using your arduino

4. Make your SD application more easier and simple
5. Communicate with Arduino using SPI interface
6. Push-pop socket with card slightly over the edge of the PCB so it's easy to insert and remove

4.6 OLED display:

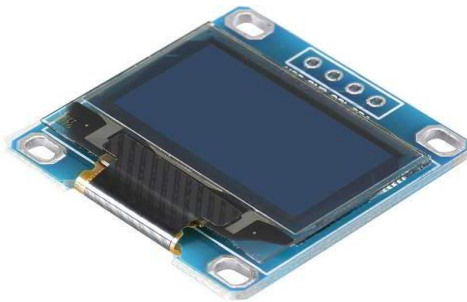

Fig -9: OLED display

OLED (Organic Light Emitting Diodes) is a flat light emitting technology, made by placing a series of organic thin films between two conductors. When electrical current is applied, a bright light is emitted. OLEDs are emissive displays that do not require a backlight and so are thinner and more efficient than LCD displays (which do require a white backlight). OLED panels are made from organic materials that emit light when electricity is applied through them. Since OLEDs do not require a backlight and filters (like LCD displays do), they are more efficient, simpler to make, and much thinner - and in fact can be made flexible and even rollable. OLEDs have a great picture quality - brilliant colors, infinite contrast, fast response rate and wide viewing angles. OLEDs can also be used to make OLED lighting - thin, efficient and without any bad metals.

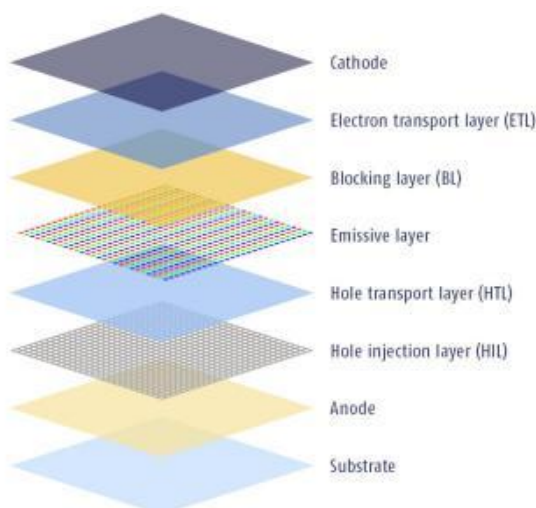

Fig -10: OLED display layers

Modern OLED devices use many more layers in order to make them more efficient and durable, but the basic functionality remains the same. An OLED panel itself is made from a substrate, backplane (electronics - the driver), front

plane (the organic materials and electrodes as explained above) and an encapsulation layer. OLEDs are very sensitive to oxygen and moisture and so the encapsulation layer is critical. The substrate and backplane of an OLED display are similar to those of an LCD display, but the front plane deposition is unique to OLEDs. There are several ways to deposit and pattern the organic layers. Currently most OLED displays are made using vacuum evaporation, using a Shadow Mask (FMM, Fine Metal Mask) to pattern. This is a relatively simple method but it is inefficient (a lot of material is wasted) and very difficult to scale up to large substrates.

5. METHODOLOGY:

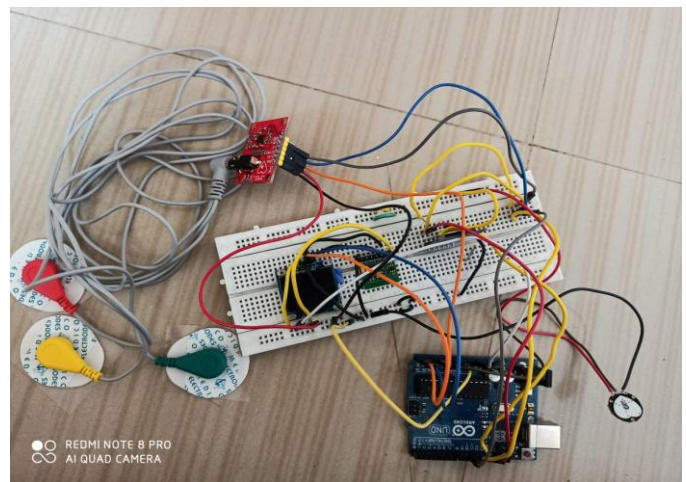

Fig -11: Complete holter monitor system

The proposed system is complete holter monitor, which is used for cardiac monitoring. Holter monitor is basically used for monitoring ECG (cardiac monitoring), but in this system we included two more parameters. Heart rate and oxygen percentage present in blood are the major parameters and are much important in diagnosis process. The system includes three modules to calculate heart rate, ECG signal and oxygen percentage in blood. Arduino microcontroller is used to control modules. There are many different ways to calculate heart rate, and in this project we built one algorithm which takes heart beats for 15sec and converted it to BPM. The output of ECG module is analog signal. So, we can directly store ECG into SD card and display it on OLED. Oximeter is used to measure oxygen percentage in blood. The main aim of this project is to make holter monitor light weight and low cost. The ECG module is having electrodes, and that electrodes patient need to wear for measuring ECG. Electrodes of ECG sensor causes skin penetration and patches. We can use this system in different ways like remote health monitoring and wearable health monitoring and so on.

6. SOFTWARE IMPLEMENTATION AND RESULTS:

6.1 Pulse sensor:

The output of pulse sensor is analog signal. The Arduino Uno ADC is of 10 bit resolution (so the integer values from (0 - (2¹⁰) 1023)). This means that it will map input voltages

between 0 and 5 volts into integer values between 0 and 1023.

Algorithm for pulse sensor:

- Step 1:** Start
- Step 2:** Declare variables:- counter1=0, counter2=0, BPM=0, cprev=0, flag=0, lastflag=0
- Step 3:** Read the value from pulse sensor
- Step 4:** for(15 sec) do
 - If Value < Threshold
 - counter1+=1
 - If counter2 = cprev
 - flag=1
 - Lastflag = flag
 - Else if Value > Threshold
 - Counter2+=1
 - If counter2 = cprev
 - flag=1
 - else
 - cprev=counter2
 - flag=0
 - BPM+=1
 - lastflag = flag
 - BPM=BPM*4
 - Print (BPM)
- Step 5:** Stop

In this algorithm, first we calculated heart rate value for 15sec then converted to BPM (Beats Per Minutes) In figure c is variable in which BPM values are stored.

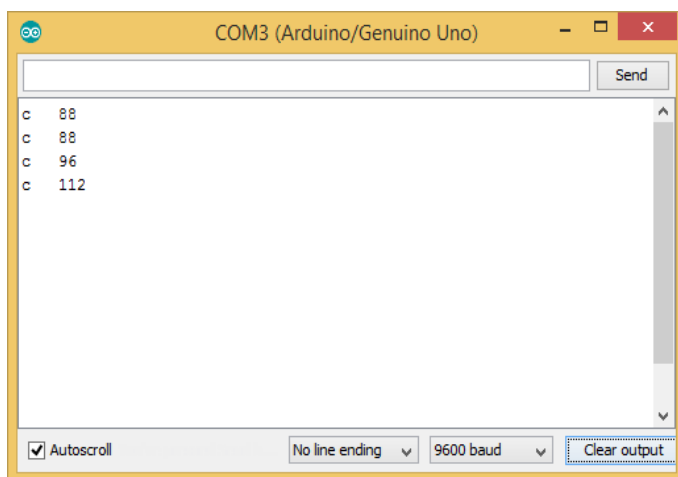

Fig -12: Calculated BPM values

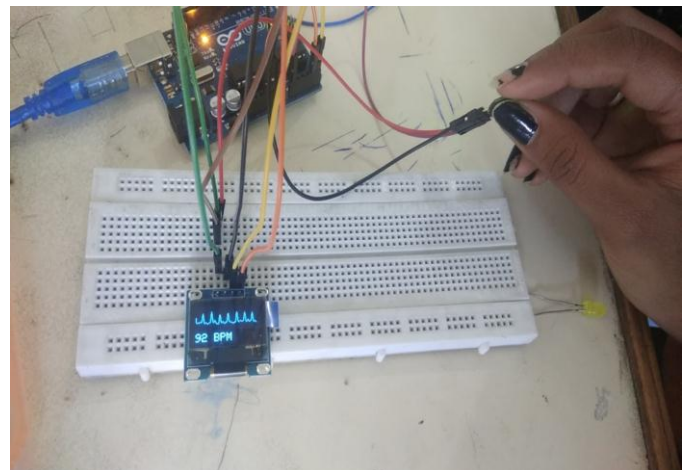

Fig -13: Heart rate display using OLED

6.2 Pulse Oximeter:

A peak detection algorithm is used to determinate the AC component of the signal that is generated by the pulsatile arterial blood absorption. This is the part of the signal which is used for SpO2 and beats per minute (bpm) calculation.

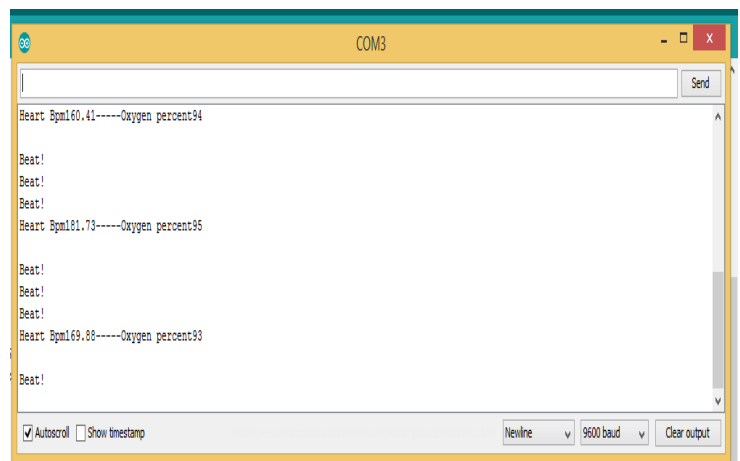

Fig -14: Output of pulse Oximeter

6.3 ECG Module:

The output of ECG sensor module AD8232 is analog signal. The AD8232 is an integrated signal conditioning block for ECG and other biopotential measurement applications. It is designed to extract, amplify, and filter small biopotential signals in the presence of noisy conditions, such as those created by motion or remote electrode placement. The ECG signal is displayed by using module. It has total three electrodes. These are connected in following manner to body of human being.

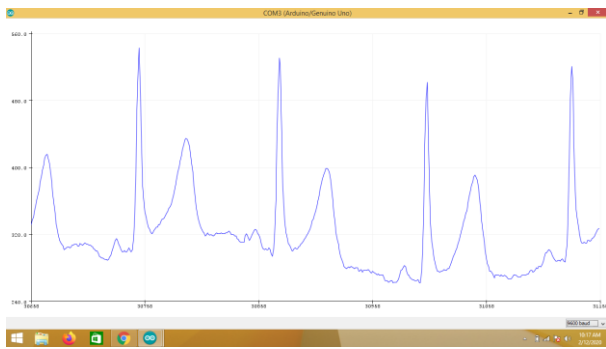

Fig -15: Analog output of ECG sensor module

6.4 Complete holter monitor outputs:

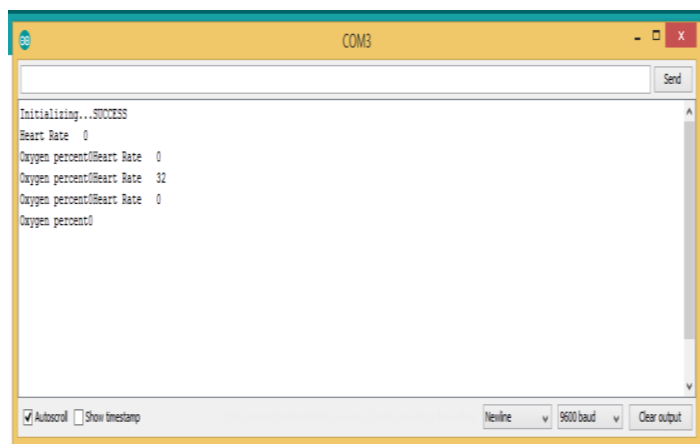

Fig -16: Heart rate and Oximeter readings

All Biomedical data of patient is extracted using sensors. Microcontroller Arduino is used for controlling modules and further processing. The data is stored in the SD card and display on OLED display. Pulse value in BPM and Oxygen percentage is stored in one file of SD card. Using online IOT platform like Blynk and Ubidot we can easily send data on cloud to make system real time. The proposed system has low cost and lighter in weight than holter monitor present in market. This system gave appropriate results as there are no any faulty readings in heart rate and ECG signal. But there is possibility that we get faulty result for pulse oximeter due to presence of carbon monoxide. The Figure 5.2 shows data stored in SD card.

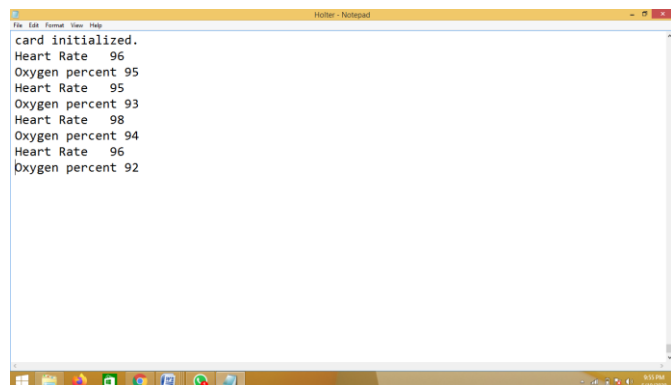

Fig -17: data stored in SD card

7. CONCLUSION:

The proposed system named as Complete Holter Monitor gives appropriate data. The major parameters are considered to make complete holter monitor is heart rate, ECG signal and oxygen percentage percentage in blood. The readings of heart rate and ECG signals are proper. The system is very light weight and low cost. We are storing data on SD card as well as displaying it on OLED display. Data stored in SD card will help doctor to diagnose diseases of patient and OLED display will give current status of parameters to patient. This data can be sent on Blynk for real time data access.

8. REFERENCES:

- [1] Ramya K, Vimal T, Sampath kumar K, Sudhagar G, "Wearable Device for Health Monitor", International Journal of Engineering and Advanced Technology (IJEAT) ISSN: 2249 – 8958, Volume-9 Issue-4, April 2020
- [2] Sowmyasudhan S and Manjunath S, "A wireless based real-time Patient monitoring system", International Journal of Scientific & Engineering Research, vol. 2, no. 11, Nov. 2011.
- [3] Harshal S Yeotkar, Dr. V.T. Gaikwad, "IOT BASED HUMAN BODY PARAMETERS MONITORING BY USING WEARABLE WIRELESS SENSOR NETWORK", International Research Journal of Engineering and Technology (IRJET), Volume: 06 Issue: 07, July 2019
- [4] Chaitali Kulkarni, Himani Karhade, Sonali Gupta, Prashant Bhende "Health Companion Device using IoT and Wearable Computing" 2016 International Conference on Internet of Things and Applications (IOTA) Maharashtra Institute of Technology, Pune, India 22 Jan - 24 Jan, 2016.
- [5] Supriya Kale, Satendra Mane, Pravin Patil, "IOT based Wearable Biomedical Monitoring System", International Conference on Trends in Electronics and Informatics ICEI 2017