

# SMART INFUSION CONTROL SYSTEM AND APPLIANCE AUTOMATION USING EYE BLINK

SWARAJ A S<sup>1</sup>, SUJIT M NAYAK<sup>2</sup>, VISHNU TEJA B<sup>3</sup>, VISHNU K R<sup>4</sup>, MAMATHA V<sup>5</sup>

<sup>1,2,3,4</sup>Student Dept. of Computer Science and Engineering BIT, Bangalore

<sup>5</sup>Professor, Dept. of Computer Science and Engineering BIT, Bangalore

\*\*\*

**Abstract** – Drip system is one of the basic equipment that is used in every hospital. And one of the basic problems is the reverse flow of blood after the bottle is empty. This and for immobile people can't interact with their surroundings. So, this paper overcome these problems we have used solenoid valve, Hall flow sensor, relay, ESP 8266 Wi-Fi Communicator for drip system and image processing algorithms like Haar Cascade Classifier to capture the eye blink counts to operate the surrounding appliance. Testing results prove that the proposed approach is 98% overall accuracy and 100% detection accuracy at a safe distance of 35cm.

**Key Words** solenoid valve, Hall flow sensor, relay, ESP 8266 Wi-Fi Communicator, Haar Cascade Classifier.

## 1. INTRODUCTION

Health monitoring systems are one of the chief usage of the technology and it is essential in many cases. It has been proved a very efficient role in monitoring of a diagnostic procedure, optimal maintenance of a chronic condition or during supervised recovery from an acute event or surgical procedure. In many cases the reverse flow of blood will occur due to negligence, or the absence and restlessness of the medical staff. This is a serious problem and measures must be taken to overcome this. Thus, we are proposing a automated drip control system.

One of the major loss of an paralyzed or immobile person is not be able to communicate with his surroundings like fan, light, voice command. We proposed automated appliance control using eye blink as it is simple and efficient way.

### 1.1 MOTIVATION

Due to lack of proper monitoring of patients and the inability of an immobile patient to communicate with his surroundings lead for us to develop this project. And to improve the effective monitoring of patient, making patient a comfortable stay in hospital.

### 1.2 AIM AND OBJECTIVES

The main cause for this paper is to build a system to an hospital room. Where it makes easy for medical faculty to

monitor the patient drip system and help an immobilized person to communicate with his surroundings.

The main objectives of this project are:

Monitoring the temperature and pulse of the patient.

Transmitting patient related information using LORA to PC. Interfacing the Hall flow sensor and inlet, outlet and verifying the flow rate. Face detection, pose estimation landmark estimation and voice conversion.

## 1.3 PROPOSED SYSTEM

In this system we are using solenoid valve, Hall flow sensor, relay to control the flow rate of the fluid and signal the doctors using Wi-Fi Communicator when the liquid level reaches below a certain threshold.

And we use the Haar Cascade Classifier to capture the face and detect the eye region and count the eye blink count to operate appliances.

## 2. LITERATURE SURVEY

Prof. Fan Yang [1] describes the proper research In order to achieve the function of the quantitative control in a variety of flow systems, a new type of electronic valve with quantitative control is designed. The valve collects flow pulse signal from the impeller Hall flow sensor. STM32 chip is used to calculate the flow value and cumulate the total value. It's also used to control relay in order to real-time control solenoid valve. The communication network of upper and lower computer is built through the serial port of STM32, which achieves remote real-time monitoring between the upper computer and multiple quantitative control valves. Experiment results show that the electronic valve has a high precision and the error is less than 2.5%. Prof. shuxiang Guo [2] describes about the solenoid actuator based novel type micro pump, In the medical field and in biotechnology, a new type of micro pump that can supply micro liquid flow has urgently been demanded. It is our purpose to develop a novel type of micro pump that has the characteristics of flexibility, driven by a low voltage, good response and safety in body. In this paper, we propose a new prototype model of a micro pump using solenoid actuator as the servo actuator. This paper describes the new structure and the motion mechanism of a micro pump using a solenoid actuator and discusses the possibility

of the micro pump. This micro pump consists of two one-way valves, a pump chamber made of elastic tube, and a casing. The overall size of this micro pump prototype is 18mm in diameter and 54mm in length. Characteristic of the micro pump is measured. The experimental results indicate that the micro pump has the satisfactory responses, and the proposed micro pump is able to make a micro flow and is suitable for the use in medical applications and in biotechnology. Prof. Takalkar Atul S [3] describes about This paper deals with design of nozzle/diffuser and the use of piezoelectric effect for the actuation of diaphragm of valve-less micro pump which has application in medical field for drug delivery. A three dimensional FE model of nozzle/diffuser and actuator is used for numerical simulation. Fluid flow analysis of nozzle/diffuser is performed to calculate their efficiency and frequency. The simulation is performed for variable converging and diverging angle by varying their length and width to calculate steady flow rate. Analysis of actuator unit is also carried out by using the COMSOL multi-physic software. The simulation of actuator unit depends on mechanical properties of material such as Young's modulus, Poisson's ratio. The numerical result used to predict the actual behavior of actuator unit for higher frequency range which helps in proper selection of material. The comparison between analytical and numerical results is done which helps in predicting the flow rate and actual working of micro pump. Prof Jinguo wen [4] describes The demonstrates an example of the solenoid valve driver scored on AVR microcontroller. With a discussion over the system's hardware architecture, we further explain the communication protocol between the module and system controller, as well as the corresponding software control process. Besides, we illustrate the reliability and flexibility of our design in both the software and hardware phases. The driver module has proved effective and satisfying in practices on related projects.

### 3. METHODOLOGY

#### 3.1 DRIP SYSTEM

In the Drip system the ARM, Load cell, Solenoid valve, relay, Wi-Fi model. All these are used in effective manner. The load cell always monitor the weight of the fluid in the bottle. And when the weight of the bottle reaches below a certain threshold then an intimates the doctor and concerned faculty about it using the Wi-Fi model. Even the flow rate can be controlled by the doctors sending signals to the controller (ARM) using Wi-Fi model. Then the help of solenoid valve , Hall flow sensor and relays the flow rate can be controlled. In case if there is fluctuation in the temperature(temperature sensor) or pulse(pulse sensor) the flow will be stopped and it will be intimate the doctors and concerned faculty about it.

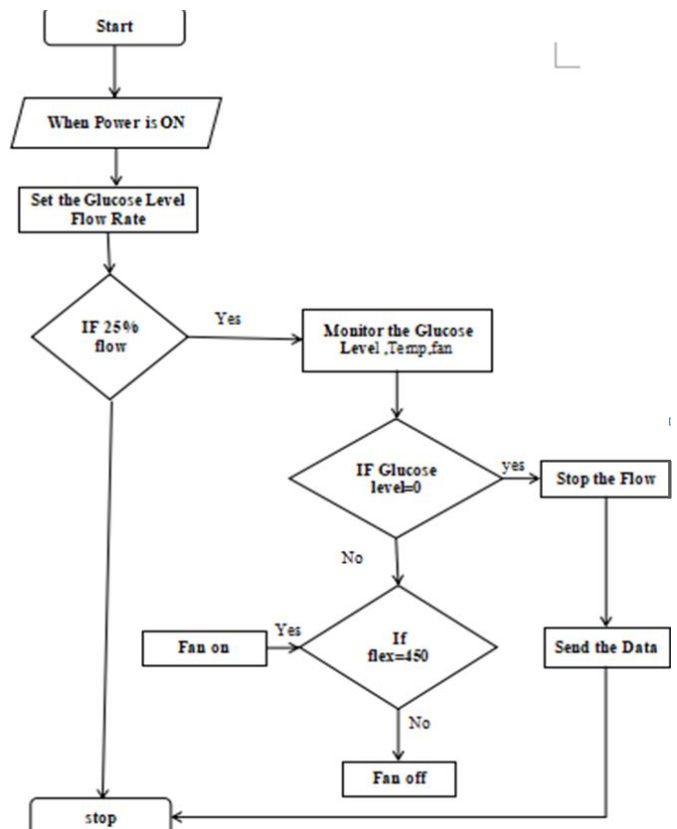

Figure 1. Drip system flow chart

If glucose level is zero then it will stop the flow and sends the data to the hospital faculty through the Wi-Fi module of his Android App. If glucose level is not zero then it checks the flex sensor is less than or equal to 450, if its yes then fan will be on, or else it will be off. The same will repeat for the 25%, 50% and 75% of the flow rates of the glucose level.

#### 3.2 EYE BLINK

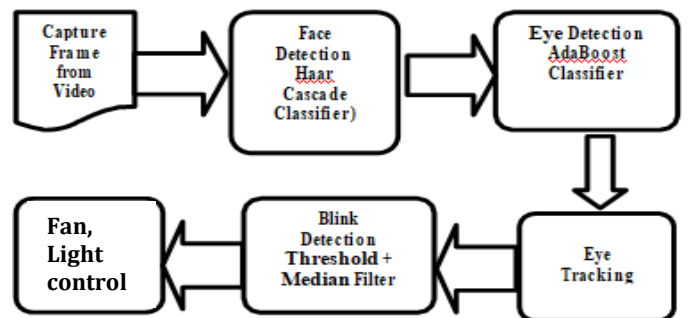

Figure 2. process of the eye blink detection

##### 3.2.1 FRAME CAPTURE

The first step of the proposed approach is to take the short video of the participant using the front camera. After which the frame method will be used to convert the video in to frames. Next the colored frames will be converted to gray scale frames by extracting the luminous component.

### 3.2.2 FACE DETECTION

The Haar Cascade classifier is used to detect the face. Haar cascade classifier rapidly detects the objects not based on pixels but by the features like facial features. The area of the image being analyzed for a facial feature needs to be regionalized to the location with the highest probability of containing the feature. By regionalizing the detection area, false positives are eliminated. As the result, the face is detected and marked with color rectangle and will be used later to approximate an axis of the eyes for eye detection step.

### 3.2.3 EYE DETECTION

To detect the eye region the Haar cascade classifier must be trained, the AdaBoost algorithm and Haar feature algorithm must be implemented, two sets of images are needed. One set contains an image or scene the doesn't contain the object. All detected elements from the Haar Cascade Classifier, and the result show the detected eye in color rectangle.

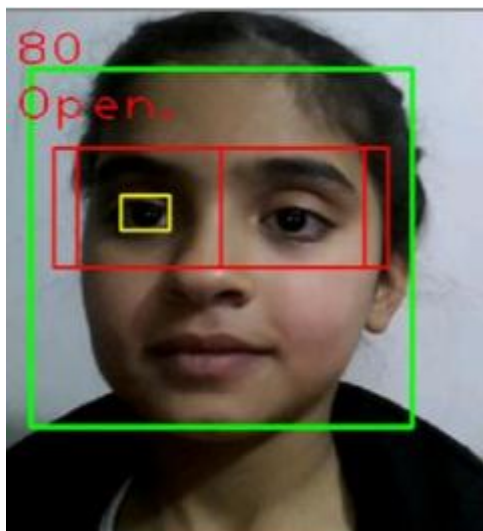

Figure 3. Detected the face and eye region by showing in colored region.

### 3.2.4 EYE BLINKING

Eye blinking can be detected by relatively high reliability by unremarkable techniques. In that the eye-gaze tracking data is used in a sensible way, since the nature of human eye movements is a combination of several voluntary and involuntary cognitive processes. The frames that have been detected earlier will be used in this step to find the status of the eye, if it is open or close. The algorithm gets 15 frames to identify the correct position of the eye. To determine the frame's pixels threshold, a binary threshold using the following equation has been applied. The threshold is initialized to 70 after experimentation we found that 70 is the best number to use. If the intensity of the pixel  $src(x,y)$  in the frame is higher than threshold, then the new pixel intensity is set to a max value. Otherwise, the pixels are set to zero.

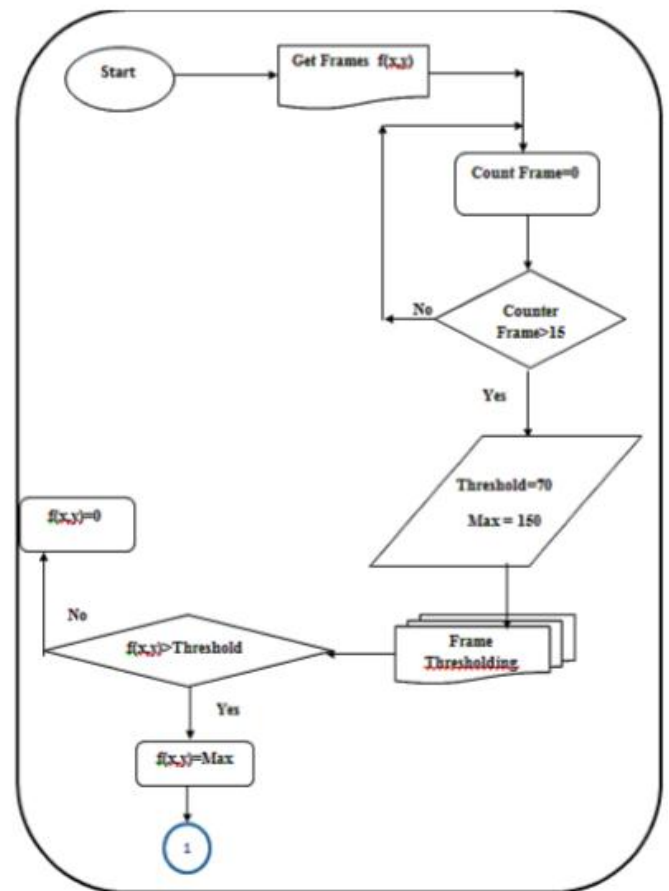

Figure 4 . Depicts the flowchart of the binarization process of the given frames and thersholding.

$$dst(x,y) = \begin{cases} maxval & \text{if } src(x,y) > threshold \\ 0 & \text{other wise} \end{cases}$$

If the state of the eye is close which means the human eye blinked. And the duration of that blink must be more than a threshold counted as a blink. In the binary frames, 0 represent the black color and 1 represent the white color for each pixel. These frames will go through a series of operations to convert all points of black and gray to zeroes and determine the length and width of the part under the eyebrows. If the index is not equal to zero, the points gray will increase. Otherwise, the number of black points will increase and this process help to discover whether the eye is open or closed. Consequently if the black points greater than 3, it means the case is open, otherwise the eye is close.

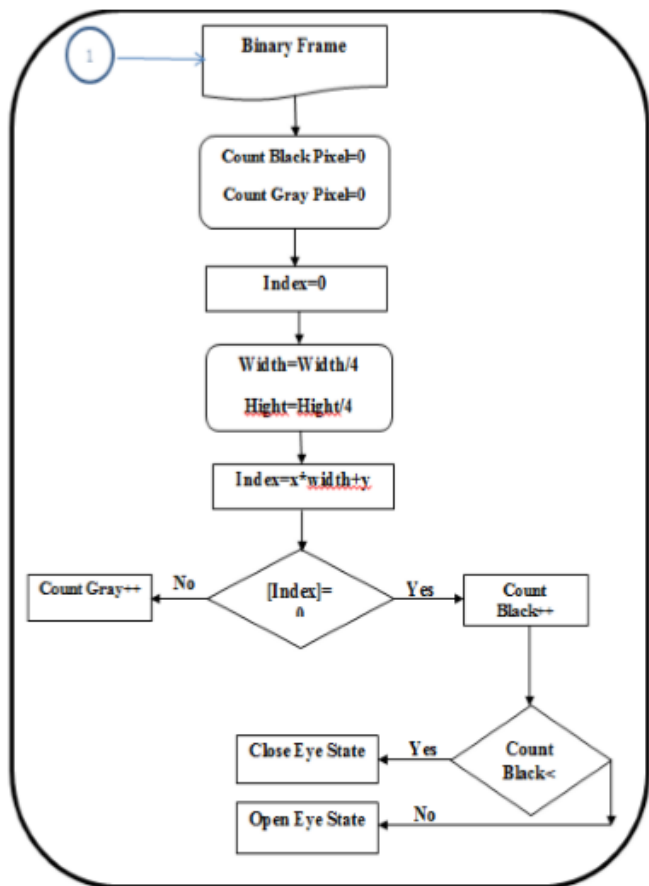

Figure 5 .Eye blink flowchart

By the help of the pixel values the status of the eye is detected.

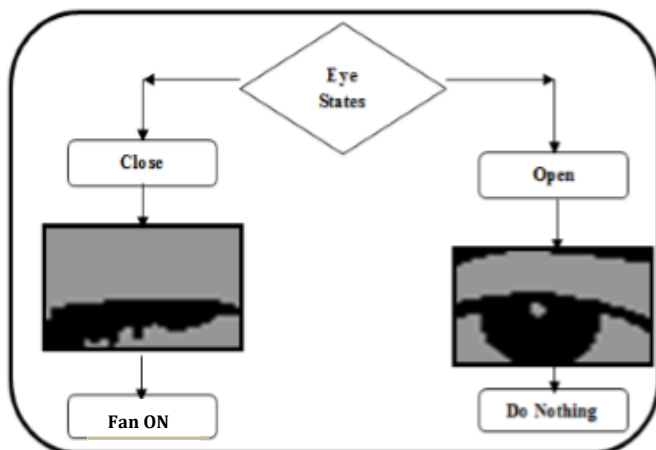

Figure 6 .Eye lid status .

### 3.2.5 PERFORMANCE PARAMETERS

The main factors that are effecting the performance of the eye blink system is the lighting condition and the distance between the camera and the face. As the distance increases the possibility of detecting the face and eye is minimal or not possible. Lighting condition also effect the possibility of

detecting. To find the accuracy the following algorithm is proposed and equation

$$\text{Over all Accuracy} = ((TP+TN)/(TP+FP+FN+TN))*100\%$$

$$\text{Detection Accuracy} = (TP/(TP+FN))*100\%$$

Where TP is the number of frames that are correctly detected eye blinks (true positive); FN is the number of frames that show eye blinks but the program is not detected (false negative); FP is the number of frames that are reported as eye blinks but they are not (false positive); and TN is the number of frames that are correctly reported as no blinks (true negative).

## 4. RESULTS

### 4.1 DRIP SYSTEM

All the components are connected in the below format.



Figure 7 . Drip system setup

### 4.1.1 THE ANDROID APP

An android app is developed and commands sent and received to monitor patient in this form.



Figure 8 . Android app developed to monitor patient.

### 4.1.2 LCD DISPLAY

The result or the status of the system will be displayed on the LCD like the Temperature of the patient, fluid level present in the bottle, and even the commands of eye blink system.



Figure 9 . LCD display of the system .

#### 4.2 EYE BLINK SYSTEM

The commands given through eye blink will be shown on LCD as in figure 9.

The system is tested in different distances to know the performance of the system.

The distance between the eye and camera are taken into account , ranging (15,20,25,30,35,40,45)cm.

With good lighting condition .

Distance (cm)	TP	FP	FN	TN	Overall %	Detection %
15	0	0	0	0	0	0
20	0	0	18	53	75	0
25	1	0	99	2489	96	1
30	3	0	265	2300	90	1
35	221	77	4	1355	95	98
40	142	16	30	2671	98	83
45	2	0	10	26	74	17

Table 1 . Overall and Detection accuracy Vs. Distance

#### 5. CONCLUSIONS

The model helps the hospital faculty to monitor the patient effectively and even helps patient to operate the surroundings using his eye blink. Even you can store the pre recorded voice commands (like calling doctor or nurse, help etc.) can be set to certain number of eye blink count. Drip system the continuous flow of medicine through drip to the patient is automatically controlled for three different flow rates 25 %, 50%, 75% of the IV cannula pipe. This can be done by measuring the level of medicine through the drip and is compared with set point and flow of medicine is stopped when it reaches the desired critical point which helps by stopping the reverse flow of the blood when the bottle gets empty and even notifies the concerned faculty. As the model implies the knowledge of image processing by applying Haar Cascade Classifier. And also the knowledge of IOT as used in Drip System and even knowledge of Wi-Fi model, ARM, API creation and android app. The eye blink system works effectively and detection accuracy are 95% and 98% respectively for a distance equal to 35 cm. In the presence of artificial light the system works effectively at 98% and detection accuracy is 100%.

#### REFERENCES

- [1] Fan Yang, Yu Wang “Research of the New Electronic Valve System with Quantitative Control” IEEE Third Global Congress on Intelligent Systems, 2012
- [2] Shuxiang Guo, Jian Wang, Qinxue Pan and Jian Guo “Solenoid Actuator based Novel Type of Micropump” IEEE International Conference on Robotics and Biomimetic, 2006
- [3] Takalkar Atul S, Lenin Babu M C “Characterization of Valveless Micro pump for Drug Delivery by Using Piezoelectric Effect” IEEE International Conference on Advances in Computing, Communications and Informatics 2016
- [4] Jingguo Wen, Zisheng Lian “Electro-Hydraulic Control System for Hydraulic Supports About the Study on Solenoid Valve Driver” IEEE International Conference on Computing, Measurement, Control and Sensor Network, 2012
- [5] Lu Quan, Sen Bao, Hong Li Jun “Research on Embedded Electro-hydraulic Proportional Valve Controller” IEEE Third International Symposium on Intelligent Information Technology Application, 2009.

#### BIOGRAPHIES



Swaraj A S  
Computer Science & Engineering  
Bangalore Institute of Technology  
Bangalore-560004



Sujit M Nayak  
Computer Science & Engineering  
Bangalore Institute of Technology  
Bangalore-560004



Vishnu Teja B  
Computer Science & Engineering  
Bangalore Institute of Technology  
Bangalore-560004



Vishnu K R  
Computer Science & Engineering  
Bangalore Institute of Technology  
Bangalore-560004