

# Arduino based Modular Mechatronics Laboratory Kits

Prasad Vengurlekar<sup>1</sup>, Prathmesh Yadav<sup>2</sup>, Utkarsha Thakur<sup>3</sup>, Reshma Pathave<sup>4</sup>, Priyanka Deshmukh<sup>5</sup>

<sup>1,2,3,4</sup>Students, Mechanical engineering Department, MCT Rajiv Gandhi Institute of Technology, Mumbai, Maharashtra, India

<sup>5</sup>Assistant Professor, Dept. of Mechanical Engineering, MCT Rajiv Gandhi Institute of Technology, Mumbai, Maharashtra, India

\*\*\*

**Abstract** – Mechatronics is platform to study advance domains of Robotics and Automation and gateway to Industry 4.0. To provide knowledge to students in this subject is a difficulty when it comes to institutions with limited resources and financial capital. This project provides a technique to the institutions to enhance the teaching learning process in the subject of Mechatronics through the use of this system. The main objective of our project is to design and fabricate modular Mechatronics laboratory kits for students training and experimentation purposes. The main objective is to provide student and instructor friendly kits which would require minimum maintenance and provide a platform to perform multiple experiments. Our prime focus is to bridge the gap between the theory and practical sessions. For the efficient use of the kits for learning purpose the kits have an Arduino board based platform whose programming is easier than the other control system platforms. For enhancing the instructor's role the kits are controlled by the instructor's command using a remote controlled interface module.

**Key Words:** Mechatronics, Modular, Arduino Mega 2560, Laboratory kits, Mechanical Engineering.

## 1. INTRODUCTION

Mechatronics is the subject that allows mechanical engineers to become compatible with the modern industrial revolution of Industry 4.0. But educating students with the knowledge of Mechatronics is a difficult task. The internet provides a huge source of information about the theoretical knowledge but less importance is given to practical knowledge and even less importance to make it low cost, efficient and multidisciplinary. This practical knowledge demands for better laboratory instruments and a link between the theory and practical sessions. It is observed that often this link is misunderstood as buying advance and expensive laboratory instruments. This misunderstanding can be beneficial many a times but still it involves a lot of capital of the institute, training and security.

Now, if we focus on the subject of Mechatronics then we can conclude that it is mostly related to Mechanical Engineering students but involves concepts which are from various domains such as Electronics, Computer Science and Automation. It also serves as a platform for the students to learn advance domains such as Robotics. Hence it is important for the institutes to involve students in the

process of laboratory development since they can provide the best feedback about the teaching methods. The subject is usually a single semester subject due to which many institutes are uninterested in investing a lot of capital for the laboratories. But still institutes can take help of students to develop experiments which can be run on a single microcontroller or microprocessor platforms such as Arduino, Raspberry Pi, etc. and submit them as their course projects.

The laboratory kits described ahead not only fulfils the demand of knowledge and instruments but also provides a platform for the students to design experiments of their own to be taught to others. It is not just equipment but it is a technique which includes instruments, procedures and methods to improve the teaching learning process. We describe them as "Modular Mechatronics Laboratory Kits". These kits are primarily based on Arduino platform.

## 2. LITERATURE REVIEW

The development of kit involves factors that have to be taken into consideration such as the syllabus, knowledge of students, different techniques to perform experiments, feasibility of kits, etc. All these factors are thoroughly studied in literature survey. Along with these factors we have studied the laboratory development of other universities which have Mechatronics engineering as a graduate degree course. We have drawn some conclusions from our studies which are described ahead.

In 2007, R. Sell et al described the various ways to carry out the training of the students in microcontroller programming to make them understand it better and practice it without having loss of hardware. It also included that the microcontroller selected for training should be easily programmable by the students of Mechanical Engineering with the aid of knowledge they had learned till their training. These techniques also stated the use of the modular stacking kits to compact the kit size. They also stated the development of the free software for easy learning. The prime output of their study was development of a cloud based virtual laboratory for carrying out research and education without the need of the lab and just accessing the equipments over the internet using a customized software.<sup>[1]</sup>

In 2014 at International Conference of Teaching, Assessment and Learning, three faculty members of engineering from Thailand shared their results of

implementation of Arduino in their laboratory experiments and their applications exhibited by their students in the semester projects. The results stated that Arduino can be used as a low cost platform for teaching Mechatronics to students. It enables the students to self learn the programming over the internet and apply it to generate new applications using the Arduino. They also demonstrated the complex technology of 3D printer using Arduino ATmega 2560 board. [2]

In 2017, a consultant in Silicon Valley, Nikola Zlatanov published a technical report on the DC power supplies. The report provides information about various types of conversion techniques, circuits for DC power supplies, load connection techniques and the measurement of voltage and current at the output terminals of the power supply. For designing laboratory equipments, it is necessary to have safety of the students and the operators. The power supplies on which equipments work are ensured to provide the purpose of safety along with providing required power to the equipments. [4]

In 2014, Jorge Juan Gil et al published the results of running an actuator on Arduino and its performance based on the current characteristics with and without heat dissipating model. The result states that if improper heat management is done then it can degrade the output of the actuator and can also damage the Arduino board even leading it to failure. [3]

In 2006, Tarek A. Tutunji et al published Mechatronics curriculum development at the Philadelphia University in Jordan. The Philadelphia University in Jordan developed its syllabus based on the requirement of the industries. They developed their laboratory equipments based on the simple design and circuits which can be easily grasped by the Mechanical Engineering students. They developed programs based on the C language and circuits based on operational amplifier. [6]

In 2005, Victor Giurgiutiu et al published the laboratory developments in Mechatronics education at the University of South Carolina. The University of South Carolina updated its curriculum based on the real life problems in the industries. But they developed the complex systems which can better train the students in dealing real life problems. They used Motorola ICs and modules which can be customized readily using any of the programming language. They also developed a simulation and emulation software which is used to virtually test the laboratory equipments over any personal computer. [5]

In 2016, the Mumbai University syllabus of the Mechanical Engineering was revised to Choice Based Credit and Grading System. This syllabus included the subjects of Mechanical Measurement and Control, Mechanical Measurement and Control Laboratory, Mechatronics, Mechatronics Laboratory, Industrial Automation and Industrial Electronics as single semester subjects in an 8 semester degree course. These subjects are directly linked to the advance domains of Robotics and Automation. [7]

### 3. DESIGN

The design of the kits is based on the block diagram of control system. This block diagram has sensors, signal conditioning, control unit, actuators and feedback as its components. Since the feedback is provided by the sensors itself hence it can be merged into sensors.

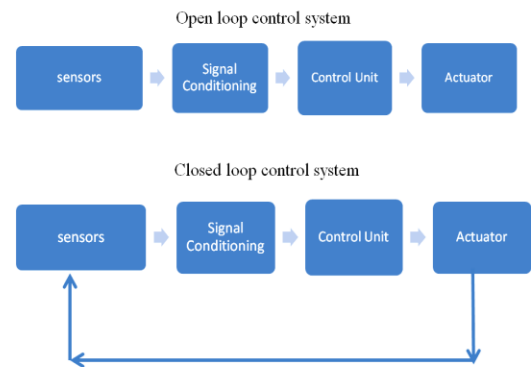

Fig 1 Block Diagram of Control System

The equipment has four components:

1. Kit 1 (six sensors and signal conditioning).
2. Kit 2 (control unit and five actuators).
3. Interface module.
4. Remote control.

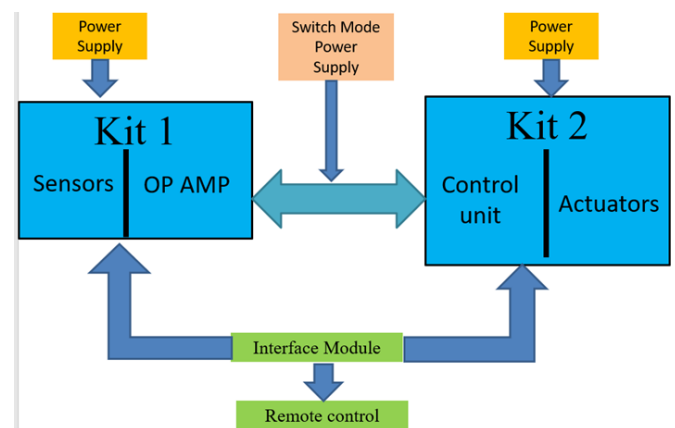

Fig 2 Layout of the System

Each component is driven by its own power supply. The signal conditioning and actuators sections also require their own separate power supplies.

#### 3.1. KIT 1

Kit 1 consists of two sections of sensors and signal conditioning. The sensors section has provision for six sensor modules. The signal conditioning section has provision for single module. The module has operational amplifier which can perform various operations on the signal along with amplification, inversion and buffering.

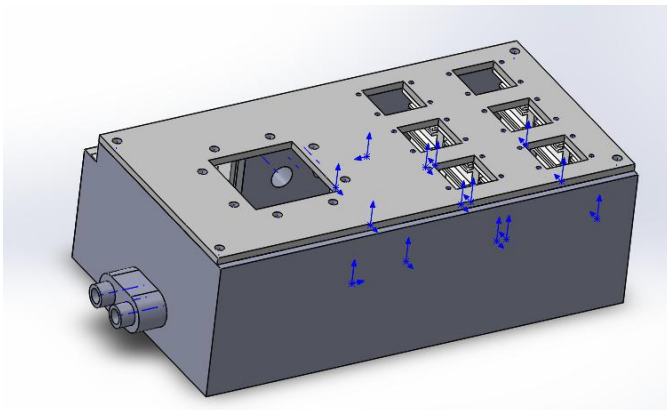

Fig 3 Design of Kit 1 in SolidWorks

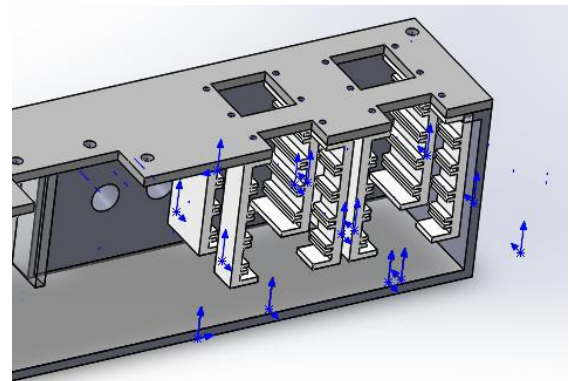

Fig 5 Cross Sectional View of Kit 1 with PCB holders Mounted to Sensors Section in SolidWorks

Kit 1 has sections where lot of circuits are involved hence a PCB (Printed Circuit Board) holder is designed which allows to mount PCB in a way which is analogous to tray system in an oven. This requires the circuit to be constructed in a vertical form as in case of Nano satellites such as CubeSats.

The use of PCB holder in signal conditioning section is dependent on the amplifier used and the techniques used in the construction of the circuits. Since amplification units require proper heat dissipation for their proper functioning hence sufficient clearance should be provided for efficient flow of air.

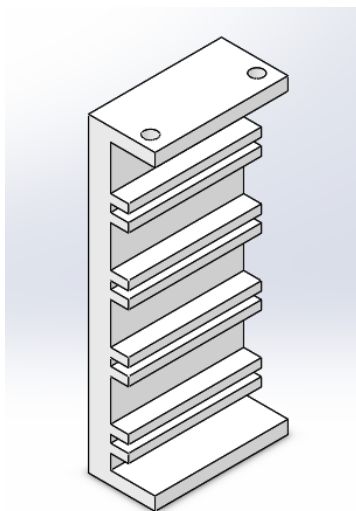

Fig 4 Design of C channel of PCB holder in SolidWorks

The PCB holder is designed to hold PCBs, breadboard, hole boards and tag boards. It consists of two C channels fixed to a square or rectangular plate on one side with nuts and bolts. The sensing part of the sensor is placed above plate while the rest of the sensor body remains inside the body of the kit. The PCB holder is secured to the body of the kit with nuts and bolts and it is easily removable.

### 3.2. KIT 2

Kit 2 consists of a control unit section with a single control unit and actuators section with provision for six actuators. It does not require the use of PCB holder since control unit has only a single PCB and actuators have their own clamping and mounting fixtures.

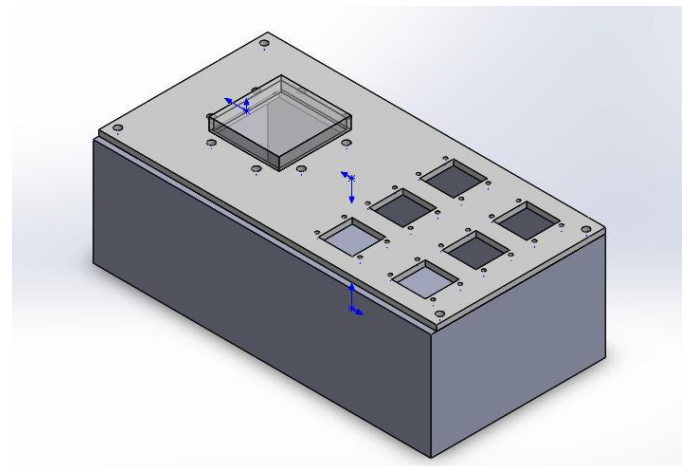

Fig 6 Design of Kit 2

It also requires an exhaust fan due to heat generation in actuator operation. The heat generation can cause deflection in the operation parameters of the actuator.

### 3.3. INTERFACE MODULE

The interface module is designed to hold a single Arduino board with provision for the IR (Infrared) receiver to receive signal from the remote control. The module will also have the circuitry to control the utilities of the kit 1 and kit 2.

It is made light weight to ensure fitting to any location such as walls, panels, wood, casings, etc. It is necessary to ensure the proximity of interface module within five metres of the kits as the distance effect the working of the data bus.

### 3.4. POWER SUPPLY

Power supply is a major component for the working of the whole system. The system requires various forms of power supplies to be utilised either for the operation or for the performance of the experiments.

The kits have controller Arduino boards inside them having requirement of 5V DC power supply. But the power regulator on board reduce the actual voltage to less than 5V hence, power supply of 7V to 12V is used to power the Arduino boards through their power input jack socket.

The hardware inside the kit for proper operation also requires DC power but the signal conditioning section and actuators section requires high power inputs which are provided by the laboratory grade DC power supply units. The Arduino boards are supplied power using 9V SMPS (Switched Mode Power Supply) Adaptors which are commercially available in the markets at very lower rates than the bulky power supplies.

The sensors derive their power from the Arduino Mega board used as a controller unit inside the kit. But still sensors can use external power supply if they require variable supply to study their various characteristics. For experimentation purposes ac signals are required to study the response of various systems. It can be easily fulfilled using a signal generator.

### 3.5. MATERIALS

All the modules are designed for easy installation and uninstallation from the kits. The body of the kits are realised using polymer switch box blanks and the various structures are made from the same polymer blanks used for the body of the kits. The switch boxes available in market are made of either ABS (Acrylonitrile Butadiene Styrene) or Polycarbonate with certain additives. Both the materials are suitable for realising the body of the kit.

Acrylic sheets of 2mm thickness are used as protection panels for the screens and covering lids for ensuring protection against impacts.

### 5. HARDWARE

The kits use Arduino Mega 2560 as their controllers. The interface module is also an Arduino Mega 2560 with VS1838 infrared receiver. The control unit section is also an Arduino Mega 2560.

The modules are switched ON and OFF using relay modules. Kit 1 utilise one 8 channel relay module and one 4 channel relay module. Kit 2 utilise only one 8 channel relay module.

The sensors section has five sensors which include a piezoelectric plate, Hall Effect sensor, digital waterproof temperature probe, Thermistor and a pair of infrared LED (Light Emitting Diode) and photodiode. The signal conditioning section has an operational amplifier in the form of IC 741.

The actuators section has DC motor, stepper motor, servo motor and Rotary Optical Encoder. Kit 1 has an LCD (Liquid Crystal Display) screen for displaying the various readings from the sensors.

An exhaust fan system is installed on both the kits to ensure proper flow of air inside the kits. It is based on the IC 555 timer and utilises a coreless DC motor.

### 6. SOFTWARE AND PROGRAMMING

The kits are designed using the SolidWorks 2015 software. The programming of the Arduino Mega 2560 is realised using Arduino IDE software. The programming code is designed in a way to ensure that any sensor or actuator can be added without any obstruction in the operation of the other sensors and actuators.

The code utilises an IRremote library which is included in Arduino IDE software externally. The structure of the code is in the form of switch case statements. The code also utilises user defined functions which can perform many commands in a single declaration.

### 7. Working

The working of the system is realised using a data bus for communication between the Arduino boards in the system. The I<sup>2</sup>C (Inter Integrated Circuit) bus is used for communication and data flow.

#### 7.1. I<sup>2</sup>C BUS

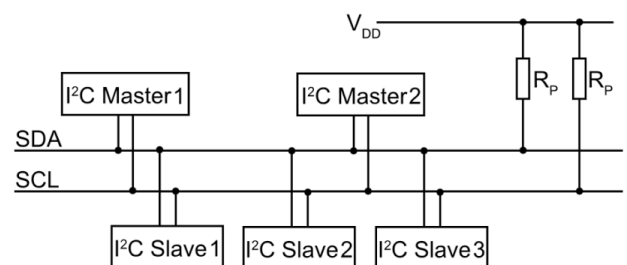

Fig 7 I<sup>2</sup>C Bus Connection Diagram

I<sup>2</sup>C stands for Inter-Integrated circuit. It is a synchronous, multi-master, multi-slave, packet switched, single ended; serial computer bus invented in 1982 by Phillips Semiconductor. It is widely used attaching lower speed peripheral ICs to processors and microcontrollers in short distance intra board communication. It uses only two bidirectional open collector or open drain lines, Serial Data Line (SDA) and Serial Clock Line (SCL), pulled up with

resistors. Typically used voltages are +5V or +3.3V. Other voltages are also permitted. Common I<sup>2</sup>C speeds are 100 kbit/s in standard mode and 400 kbit/s in fast mode. The number of nodes which can exist on a given I<sup>2</sup>C bus is limited by the address space and also by the total bus capacitance of 400pF, which restricts communication distances to a few meters. The relatively high impedance and low noise immunity requires a common ground potential which again restricts practical use to communication within the same PC(Personal Computer) board or small system of boards.

## 7.2. OPERATION

The remote control transmits an IR (infrared) signal at 38 kHz frequency which is modulated as per the protocol used by the remote control. The signal is received by the IR receiver of the interface module. This receiver is coupled with the Arduino which converts this signal into a hexadecimal code which is unique for every key of the remote. After receiving and converting the signal, the Arduino transmits a unique string of bits over the I<sup>2</sup>C bus. The Arduino also transmits the address to which the string is to be sent.

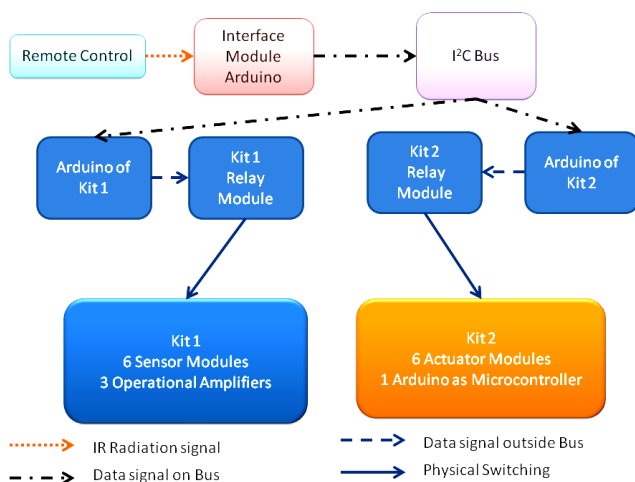

Fig 8 Working Diagram of System

The Arduino in the kits receive the string of bits over the I<sup>2</sup>C bus. The string is received only by the Arduino whose address is assigned by the interface module along with it. The Arduino in the kit has the combinations of modules to be activated as per the experiments in the form of switch cases. These switch cases basically contain the functions required to run the various sensors and actuators and also the commands that are required to be sent to LCD screen for display and to the relay module. When the string received from the bus matches with the switch case variable then the commands within that switch case are executed.

The system has 16 individual modules which are switched in various combinations depending upon the requirements of the experiment to be performed. The process of receiving the commands is continuously done in the system due to the use of Arduino. When the command or the string is not received over the bus the system executes the previous switch case commands till the Arduino is reset or the power is cut off the board.

## 8. ADVANTAGES

- The system has modular structure which allows installing or removing the components easily.
- Due to Arduino used as a control unit, it becomes easier for the Mechanical Engineering students to understand the code as it is based on C language.
- There are many sensors in the market which are compatible with the Arduino boards and require generally only three terminals to connect to the board. This allows making multiple modules and using them as per the requirement.
- Students can design their own sensors, actuators or experiments and make them compatible with the Arduino parameters and operate on the kits as a single module.
- Due to modularity of the kits, the failure of the components is localised to a single part of the kit while the other parts of the kits remain operational.
- The whole system contains four Arduino boards performing various functions but the equipment can perform experiments with aid of single Arduino with limitations on the certain functions.

## 9. LIMITATIONS

- The design of the kit is specifically done for the students of Mechanical Engineering.
- The Arduino Mega 2560 is a microcontroller which cannot perform large computations and store them due to memory issues.
- The kits are incompatible with experiments having large power requirements.
- The data bus used is only suitable for short distances. For long distance data transmission it requires additional hardware and settings.

## 10. FUTURE SCOPE

- The use of remote control can be replaced with Bluetooth, WI-Fi, radio transmitter or Internet of Things.
- The data bus can be replaced with other data bus systems available which are compatible with Arduino.
- The Arduino boards can be replaced with Raspberry Pi boards but it can increase the cost of the kits.
- The number of modules the kits can hold can be increased with increase in size of individual kits.

## 11. CONCLUSIONS

The main objective of our project was to provide laboratory equipment which can provide a link between the theory and practical sessions. We also implemented a modular design in it so that the cost is reduced. This also generated a test platform for the students to implement their own

experiments in the laboratory other than only learning. There are several companies which offer laboratory equipments to institutes but their maintenance is difficult as the structure and working is designed by the company to earn profit and is a generalized one. But still it is difficult to understand it.

Our project allows institutions to design their own equipments by participation of students and teachers together whose structure is made by the institution, for the institution and is specific to the requirements of the institution.

Our project work is based on the syllabus of Mechatronics. But it is not necessary to apply the techniques, designs and algorithms only to the same subject. It can be implemented for any subject and can be based on any other ideas too. The experiments designed are specific to Mechanical Engineering students who have limited knowledge about programming and electronics. Some of the implemented components and systems are worth of improvement with different materials which reduce the weight and size of the equipments.

## ACKNOWLEDGEMENT

We would like to express our sincere thanks to Prof. Priyanka M. Deshmukh of Mechanical Engineering for her guidance and supervision in all respects of this paper.

## REFERENCES

- [1] Sell, R., Seiler, S., Ptasiak, D., 2014, "Microcontroller Based Intelligent Platform for Research and Education in Mechatronics".
- [2] Sell, R., Seiler, S., Ptasiak, D., 2014, "Microcontroller Based Intelligent Platform for Research and Education in Mechatronics," International Conference of Teaching, Assessment and Learning (TALE).
- [3] Gil, J.J., D'iaz, I., Justo, X., Ci'aurriz, P., 2014, "Educational Haptic Controller based on Arduino Platform," 978-1-4799-6002-6/14/\$31.00 © IEEE.
- [4] Zlatanov, N., 2017, "DC Power Supplies, Applications and Measurements," Technical Report: January DOI: 10.13140/RG.2.2.27236.17288.
- [5] Lyons, J., Rocheleau, D., Liu, W., 2005, "Mechatronics/microcontroller education for mechanical engineering students at the University of South Carolina. Victor Giurgiutiu," Elsevier Ltd.
- [6] Tutunji, T., Jumah, M., Hosamel-deen, Y., Abd Rabbo, S., 2006, "Mechatronics curriculum development at Philadelphia University in Jordan," Published by Elsevier Ltd.
- [7] Mumbai University Choice Based Credit and Grading System Revised Syllabus (Rev - 2016) under Faculty of Technology in Mechanical Engineering.