

DESIGN OF ICE CANDY MACHINE

Prof. Krunal Parikh¹, Tejas Bhalani², Sameer Gondaliya³, Ronakkumar Pansheriya⁴, Smit Gajera⁵

¹Assitant Professor Department of Mechanical Engineering IITE, INDUS UNIVERSITY, Ahmedabad

²³⁴⁵Students, Dept. of Mechanical Engineering IITE, INDUS UNIVERSITY, Ahmedabad

Abstract - Refrigeration may be defined as the process of achieving and maintaining a temperature below that of the surroundings, the aim being to freeze ice, cool some product, or space to the required temperature. One of the important applications of refrigeration is in ice candy machine. Ice candy machine is used for producing refrigeration effect to freeze (water + syrup) in standard molds placed in rectangular tank which is filled by brine. Our project based on simple refrigeration system which uses the vapour compression cycle. The vapour compression cycle comprises four process compression, condensing, and expansion and evaporation process. Our ice candy model contains various parts such as- Compressor, condenser, filter drier, Expansion valve, Evaporator coil etc. The model is analyzed for its cooling capacity assumed per unit mass flow rate of refrigerant. Its COP is also calculated. The model is compared for its coefficient of performance (COP) and cooling capacity by using R-134a refrigerant with a theoretical COP.

1. INTRODUCTION

An ice candy machine may refer either to a consumer device for making ice candy, a stand-alone appliance for making ice candy, or an industrial machine for making ice candy. Refrigeration may be defined as the process of achieving and maintaining a temperature below that of the surroundings, the aim being to cool some product or space to the required temperature. A good definition of refrigeration is the removal of heat energy so that a space or material is colder than its surroundings. An ice candy machine based on same principle as a simple refrigeration system. A refrigeration is always been a great deal for human being and play a vital role in preserving food, chemical, fisheries and providing appropriate temperature in working Entity of any industry. Ice candy machine manufacture is used for producing refrigeration effect to freeze potable water in standard cans placed in rectangular tank which is filled by brine solution. An ice candy machine is based on same principle as a simple refrigeration system. An ice machine contains various parts such as compressor, condenser, receiver, expansion valve, and evaporator and refrigeration accumulator. The Ice candy machine works on simple vapour compression refrigeration cycle and uses R134A as a refrigerant. These are

environment friendly. The system is fabricated such that students can observe and study ice formation process. It is also useful to understand working of vapour compression system, its performance and controls used. The arrangement of parts such that, all the parts are visible and working can be easily understood. The Ice candy Plant works on the principle of VCR Cycle. It shows the concept of indirect cooling in which the brine solution is cooled first with the help of refrigerant and then this cold brine solution cools the specimen. We have used two capillary tubes of same length and different diameter to check the performance of the plant. We are using R-134a as refrigerant as it is eco-friendly.

2. COMPONENTS OF ICE CANDY MACHINE

In the study of an ice candy machine the components generally used are viz. compressor, oil separator, condenser, receiver, drier, expansion valve, evaporator, brine Tank, refrigerant accumulator and pressure gauge.

2.1 Compressor:



The low pressure and temperature of the vapour refrigerant from evaporator is drawn into the compressor through IV or suction valve where it is compressed to high pressure and temperature. Refrigerant is discharged into the condenser through delivery or discharge valve. There are many types of compressors used in an ice plant industries depending upon its capacity. The compressor used in this model is hermetically sealed reciprocating compressor. The hermetically sealed compressor is discussed in details ahead. A semi-hermetic uses a large cast metal shell with gasket covers that can be opened to replace motor and pump components. The primary advantage of a hermetic and semi-hermetic is that there is no route for the gas to leak out of the system.

2.2 Condenser:



Condenser is an important component of any refrigeration system. In a typical refrigerant condenser, the refrigerant enters the condenser in a superheated state. It is first de-superheated and then condensed by rejecting heat to an external medium. The refrigerant may leave the condenser as a saturated or a sub-cooled liquid, depending upon the temperature of the external medium and design of the condenser. Based on the external fluid, condensers can be classified as: a) Air cooled condensers b) Water cooled condensers, and c) Evaporative condensers, in this model forced air cooled condenser.

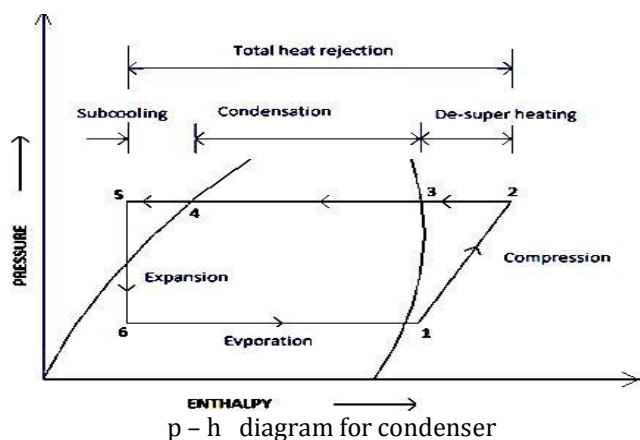

2.3 Evaporator:

The bare tube coil evaporators are also known as prime surface evaporators. Because of its simple construction, the bare tube coil is easy to clean and defrost. In its operation, the liquid refrigerant from the condenser enter the capillarity tube due to friction resistance offered by small diameter tube, the pressure drops since the frictional resistance is directly proportional to the length and inversely proportional to the diameter. The stirrer is used for uniform cooling of the brine solution. Copper tubes are used in the evaporator as it gives.

2.4 Filter Drier:

The function of filter dryer is to remove any physical material from compressor's wear and tear, and remove any moisture presence within an air conditioning system. The Drier is made up of a metal outer container and inside there is a desiccant (moisture removal material) and strainer. Refrigerant passes through the drier and give up any moisture as well as any unwanted matter. The main job of the drier is to protect the metering device from clogging either by Ice (moisture) or blockage by particles. It is not uncommon for driers and filters to block due to their nature of picking up unwanted agents - evidence of this can be seen by frost build up. Filtering process is achieved by mechanical action of partitioning the flow. Particles will be trapped, whilst the refrigerant flow will be maintained. These desiccants can be of two types, viz. absorbent and adsorbent type. In this model adsorbent type filter drier is used which is defined ahead.

2.5 Receivers:

A liquid receiver will be required if it is necessary to temporarily store refrigerant charge within the system, or to accommodate the excess refrigerant arising from changing operating conditions. The total refrigerant charge required in a circuit will vary with different operating loads and ambient, and must be sufficient at all times so that only liquid enters the expansion valve. A receiver requires a minimum operating charge which adds to overall charge and cost, and also increases system complexity. Hence receivers are avoided on many smaller systems.

2.6 Expansion Devices:

The expansion device (also known as metric device or throttling device) is an important device that divides the high pressure side and the low pressure side of a refrigerating system. It is connected the receiver (containing liquid vapour at high pressure) and the evaporator (containing liquid refrigerant at low pressure). The expansion device performs the following functions like to reduce the high pressure liquid refrigerant to low pressure liquid refrigerant before being fed to the evaporator and to maintain the desire pressure difference between the high and low pressure side of the system, so that the liquid refrigerant vaporizes at the designed pressure in the evaporator. There are many types of expansion devices used viz. capillary tubes, automatic or constant-pressure expansion valve, low side float valve, high side float valve and thermostatic expansion valve in an ice plant industry depending upon its capacity. In this model the

capillary tube type expansion device is used which is discussed in details ahead.

2.7 Capillary Tube:



The capillary tube is used as an expansion device used in small capacity hermetic sealed refrigeration units such as domestic refrigeration, water cooler, room air conditioner and freezers. It is a copper tube of small diameter and of varying length depending upon the application. The inside diameter of the tube used in refrigeration work is generally about 0.5 mm to 2.25 mm and the length varies from 0.5 m to 5 m.

3. METHODOLOGY OF ICE CANDY MACHINE:

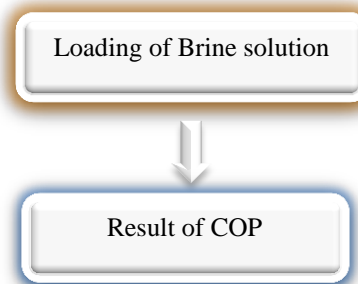
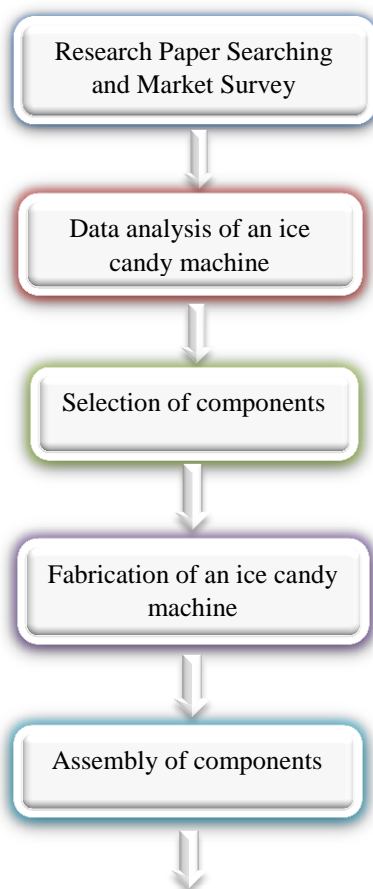

4. WORKING OF ICE CANDY MACHINE:

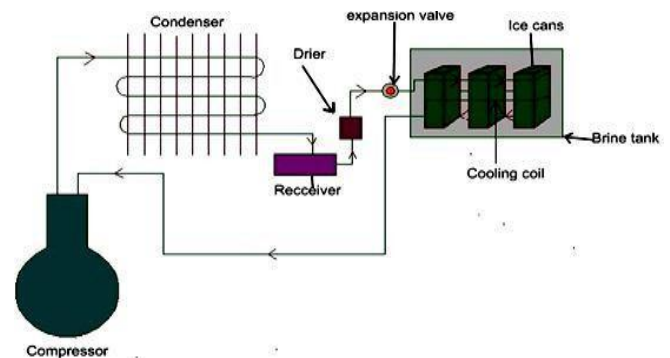

In ice candy machine the tank are filled with chilled brine. A brine temperature is maintained at -10°C . The brine is the secondary refrigerant. The primary refrigerant used do not leave the plant but it is circulated around the system alternatively after condensing and evaporating. The actual working of ice plant is shown in figure. In ice candy machine the function of expansion valve is to expand the refrigerant R-134a coming out from a receiver to low pressure as shown in fig. Then it enter the evaporator where evaporator vaporize the liquid refrigerant from expansion valve by extracting heat from brine and hence brine gets cooled and it is recirculated to water tank containing 'ice candy' to absorb heat of water to freeze it and make ice candy. Then the vaporized refrigerant is compress by the compressor to high pressure and temperature above the atmospheric which will ready to dissipates, its heat in the condenser. In condenser refrigerant is condensed by water and the refrigerant give up the heat which is absorbed in the evaporator. This heat is transferred to water which is used as cooling medium in condenser. Compressor compresses the vapour coming from evaporator and send it to the condenser for cooling. Condenser condenses the high pressure vapour and passes it to the evaporator through expansion valve. Expansion valve converts the high pressure liquid into low pressure vapour and refrigerating effect is produced in the evaporator by absorbing heat from the secondary refrigerant.

5. REFRIGERANTS:

There are many types of refrigerants, But we are using R134a (Tetrafluoroethane).

- ▶ R134a is also known as Tetrafluoroethane (CF₃CH₂F) from the family of HFC refrigerant. With the discovery of the damaging effect of CFCs and HCFCs refrigerants to the ozone layer, the HFC family of refrigerant has been widely used as their replacement.
- ▶ It is now being used as a replacement for R-12 CFC refrigerant in the area of centrifugal, rotary screw, scroll and reciprocating compressors. It is safe for normal handling as it is non-toxic, non-flammable and non-corrosive.
- ▶ It exists in gas form when exposed to the environment as the boiling temperature is -14.9°F or 26.1°C.

6. BRINE SOLUTION USED:

In this prototype model the mixture of NaCl and water in the proportion of 1:3 is used. The mixture of CaCl₂ and water can be used as brine but it is not used because of its toxicity.

- ▶ Brine is a solution of salt in water
- ▶ Used where temperatures are required to be maintained below freezing point of water
- ▶ The commonly used brines are calcium chloride, sodium chloride and glycols
- ▶ In ice making Sodium chloride is used
- ▶ The eutectic temperature of sodium chloride brine is -21.1 degree Celsius at salt concentration of 23% by mass

7. FABRICATION AND ANALYSIS OF ICE CANDY MACHINE:

The prototype model of an ice candy machine has been fabricated consist of compressor, condenser, filter drier, capillary tube, evaporator, brine tank, energy meter, pressure gauge and digital temperature indicator whose detailed information are given in the Table 1, below for the thermal analysis of model.

Table-1 : Specifications and Energy Equations for Different Components

Components	Specifications	Energy equation
Compressor	Specifications of the compressor used in project are given below: - Application with R-134a - Type -Hermetically sealed compressor - Cooling capacity (-6.7 °C): 595 W - Displacement : 9.1 cm ³	Adiabatic compression work = $m(h_2 - h_1) = mc_p (T_2 - T_1)$ Here T ₁ , T ₂ are temperatures at inlet and outlet and m is mass flow rate.
Condenser	Single role forced air cool condenser with fan. - Fin material : Aluminum - Copper tube dia. : 9.52 mm	Heat lost by steam = $m (h_2 - h_1)$, kJ
Filter drier	For use with R-134a Refrigerants	
Expansion device	- Type- capillary tube - Diameter of capillary tube is 0.05 inch. - Length of capillary tube is 6m	Throttling refers to passage of a fluid through some restricted opening under isenthalpic conditions. During flow through these passages enthalpy remains constant, such that $h_1 = h_2$

Evaporator coil	Specifications of the evaporator used in project are given below: - Diameter of copper coil : Inner diameter : 4.175 mm Outer diameter : 5.175 mm	Heat transfer rate at evaporator or refrigeration capacity, Q_e is given by: $Q_e = m_r (h_1 - h_4)$ Where m_r is the mass flow rate in Kg/sec, h_1 and h_2 are the Specific enthalpies (kJ/kg) at the exit and inlet to the evaporator, respectively. $(h_1 - h_4)$ is known as specific refrigeration effect or simply refrigeration effect, which is equal to the heat transferred at the evaporator per kilogram of refrigerant.
-----------------	------------------------------------------------------------------------------------------------------------------------------------------------------------	-------------------------------------------------------------------------------------------------------------------------------------------------------------------------------------------------------------------------------------------------------------------------------------------------------------------------------------------------------------------------------------------------------------------------------------------------

Components	Specifications
Brine Tank	-dimensions of tank: length=350mm, width=250mm, height=250mm
Candy molds	-Quantity = 8 -Material of molds are plastic

$$= 31.57 \frac{\text{kJ}}{\text{min}} = 526 \text{ w}$$

5) Brine tank calculations

- Volume of tank = $l \times b \times h$

$$= 35\text{cm} \times 25\text{cm} \times 25\text{cm}$$

$$= 21,875 \text{ cm}^3$$
- Quantity of brine = Volume of brine tank - volume of candy molds

$$= 21,875 - 1,270$$

$$= 20,605 \text{ cm}^3 = 20.6\text{L}$$
- Brine solution ratio = 1 : 3

$$= 5.15 \text{ kg salt \& } 15.45 \text{ L}$$

8. DESIGN CALCULATIONS:

1) Volume of 8 Candy

$$= 8\pi r^2 h$$

$$= 8 \times 3.14 \times 2.25 \times 2.25 \times 10$$

$$= 1270 \text{ cm}^3 = 1.27 \text{ L}$$

2) Heat to be removed from molds of candy by Brine

$$= mc_1 \Delta T + \text{latent heat of ice} + mc_2 \Delta T$$

$$= 1.27 \times 4.187 \times 28 + 335 + 1.27 \times 2.108 \times 5$$

$$= 497.27 \frac{\text{kJ}}{\text{kg}}$$

3) Ice to be produced per min

$$= \text{Volume of candies} / \text{Time}$$

$$= 1.27 / 20 = 0.0635 \frac{\text{kg}}{\text{min}}$$

4) Refrigeration capacity

$$= \text{Ice to be produced per min.} \times \text{Heat to be removed}$$

$$= 0.0635 \times 497.27$$

9. T-S diagram and P-H diagram:

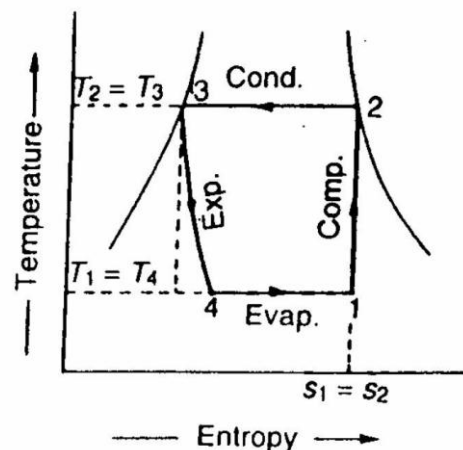

(a) T-s diagram.

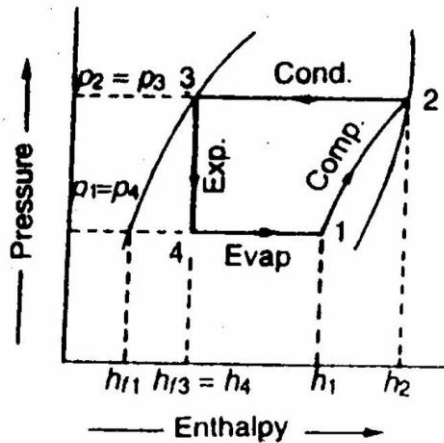

(b) p-h diagram.

STATE 1:

- Low temperature
- Low pressure
- Saturated vapour
- $p_1 = 180 \text{ kpa}$
- $T_1 = -12.7 \text{ }^\circ\text{C}$
- $h_1 = 242.9 \frac{\text{kJ}}{\text{kg}}$
- $s_1 = 0.9397 \frac{\text{kJ}}{\text{kg}\cdot\text{K}}$

STATE 2:

- High temperature
- High pressure
- Superheated vapour
- $p_2 = 1200 \text{ kpa}$
- $T_2 = 53.73 \text{ }^\circ\text{C}$
- $h_2 = 282.52 \frac{\text{kJ}}{\text{kg}}$
- $s_2 = 0.9397 \frac{\text{kJ}}{\text{kg}\cdot\text{K}}$

STATE 3:

- Mid. temperature
- High pressure
- Saturated Liquid

- $p_3 = 1200 \text{ kpa}$
- $T_3 = 46.3 \text{ }^\circ\text{C}$
- $h_3 = 117.8 \frac{\text{kJ}}{\text{kg}}$
- $s_3 = 0.4245 \frac{\text{kJ}}{\text{kg}\cdot\text{K}}$

STATE 4:

- Low temperature
- Low pressure
- Liquid/vapour mixture
- $p_4 = 180 \text{ kpa}$
- $T_4 = -12.7 \text{ }^\circ\text{C}$
- $h_4 = 117.8 \frac{\text{kJ}}{\text{kg}}$
- $s_4 = 0.46078 \frac{\text{kJ}}{\text{kg}\cdot\text{K}}$

10. BRINE AND REFRIGERANTS CALCULATIONS:

Brine calculations:

Concentration of salt (g/dm ³)	Specific heat capacity (J/gK)
0	4.80
100	3.02
200	2.87
300	2.48

Brine calculations:

- heat transfer from brine = 500 kj
- $= mc\Delta T$
- $500 \text{ kj} = m \times 2.87 \times 10$
- $m = 17.5 \text{ kg}$ (concentration of salt is 20%)

Refrigerant calculations:

- Heat transfer in evaporator = 500 kj = $m (h_1 - h_4)$
- $m = 3.99 \text{ kg}$
- Density of R134a in liquid state = 1.335 g/cm^3
- $m = \rho v$
- volume of refrigerant in evaporator = 2996.25 cm^3
- Volume of pipe = $\pi r^2 L$
- Let $L = 700 \text{ cm}$

- size of brine tank = 30×30×35 cm
- Radius of pipe = 1.17 cm

$$\text{COP} = \frac{h_1 - h_4}{h_2 - h_1} = \frac{242.9 - 117.8}{282.52 - 242.9}$$

$$\text{COP} = 3.157$$

11. NOMENCLATURE:

h = specific enthalpy

m = mass flow rate in Kg/sec

Q = heat supplied

T_1 = inlet temperature of refrigerant

T_2 = temperature of refrigerant after compression

T_3 = temperature of refrigerant after condensation

T_4 = temperature of refrigerant after expansion

p_1 = inlet pressure of refrigerant

p_2 = pressure of refrigerant after compression

p_3 = pressure of refrigerant after condensation

p_4 = pressure of refrigerant after expansion

s = entropy

h = enthalpy

v = velocity

W = work done

ΔT = Temperature difference

C = specific heat

COP = Coefficient of performance

12. RESULT AND DISCUSSION:

- The chilling tank is perfectly insulated.
- There is no heat loss from or to the chilling tank. The power input to the ice plant model is uninterrupted.
- The actual COP of the system is found to be 1.4, which is directly depends upon Refrigeration effect and inversely depend upon the work done by the system.
- If the refrigeration effect is increases by a certain value, the actual COP of the system increases or vice a versa. And if the value of work done increase then the actual COP of the system decreases or vice a versa.
- The actual COP is found out with the help of p-h diagram (R-404a chart) on the basis of the Condenser pressure and Evaporator pressure.
- The efficiency of ice plant is expressed in terms of the coefficient of performance (COP).

13. CONCLUSION:

- It concludes that theoretical COP of test rig is greater than actual COP.
- As actual COP is less than theoretical COP, the compression process is polytrophic.
- Expansion process is not exactly isenthalpic.
- Pressure drop in condenser and evaporator is takes place.
- When evaporator tank is perfectly insulated then COP of system increases.

14. REFERENCES:

- A text book of Refrigeration and Air conditioning by R.S. Khurmi & J.K. Gupta.
- A text book of Refrigeration and air conditioning by C.P. Arora.
- A textbook of Refrigeration and Air conditioning by Arora and Domkundwar.
- P. Yadav and B. R. Singh., A study on analysis and fabrication on ice plant model, Samridhhi-A Journal of Physical Sciences, Engineering and Technology (S-JPSET), 2(1), 2011.
- S. K. Wang, Handbook of Air Conditioning And Refrigeration (McGraw Hills Publication, Second Edition, 2000).
- Rex Miller & Mark R. Miller, A textbook of Refrigeration and Air Conditioning, (McGraw Hills Publication, 200604-01).