

# Adaptive Camber Suspension Strategy using PID Control

Mohammed Asif N<sup>1</sup>, Hrishikesh K Nair <sup>2</sup>, Ashwin Jacob Shaji<sup>3</sup>, Tony Davis<sup>4</sup>, Abhijith T.G<sup>5</sup>

<sup>1-5</sup>Mechanical Engineering, TKM College of Engineering, Kollam, India

\*\*\*

**Abstract** - A suspension system serves a dual purpose of providing stability to the vehicle whilst providing a comfortable ride quality to the occupants. As of now, automotive companies have focused on improving the comfort and handling of vehicles; while keeping the cost, space, and feasibility of manufacturing in the constraint. This project proposes a method for improving handling characteristics of a vehicle by controlling the camber angle adaptively using variable-length arms. The goal of the active camber concept is to generate a vehicle with extreme maneuverability. A quarter car physical model with double-wishbone suspension geometry is modeled in SolidWorks. It is then imported and simulated using Openmodelica. The output characteristics of the passive system were studied on MSC ADAMS car software. The proposed system intends to improve vehicle handling characteristics like roll stability, by controlling the camber angle. This is accomplished by incorporating a Bell-crank mechanism with a Linear Mechanical actuator which varies the camber angle of the wheel dynamically to maintain vehicle traction and prevent rollover. A PID controller is employed to trigger the actuator based on the camber angle from the sensor for reducing the error existing between the actual and desired value. A comparison between active and passive systems is carried out by analyzing graphs of variation in the camber angle obtained from the simulation done in Openmodelica. From the results, it is observed that there is a reduction of 81% in the camber angle. Hence, the system provides the scope of a considerable adaptive strategy in controlling the dynamic characteristics of the suspension system.

**Key Words:** *Maneuverability, Vehicle Traction, Roll Stability*

## 1. INTRODUCTION

An automotive suspension system is crucial to vehicle ride and performance due to its function and mechanism. The suspension system could absorb the effect from different conditions such as uneven road, bumping, cornering, sudden acceleration, and braking. There are different types of systems used in automobile, the commonly used in a passenger car are independent suspension system

It is desired that passengers have a comfortable ride as well as good control over the vehicle. The suspension system carries the total load of the vehicle and provide comfort to passengers and also delivers a good road holding when the vehicle travels on rough terrain.

A passive system is common in vehicles nowadays to control the dynamic character of vehicles, pitch, and roll. However, this system cannot provide energy to the suspension system and limits the relative velocities to a rate that contributes to ride comfort. A damping element is introduced between the body and wheels of the motor vehicle to reduce the relative velocity and vertical body acceleration to obtain good contact force.

Hydraulic shock absorbers, leaf spring, antiroll bar are some of the common dampers in the application. The primary design of a suspension system focused on reducing the suspension stiffness and unsprung mass to provide a better damping ratio. Thus, a passive system offered an appealing choice for a car. But with further development in technology and research, it was seen that the conventional shock absorbers do not provide sufficient energy and they are only able to control the displacement of the vehicle and wheel by limiting the parameters with respect to the rate determined by the engineers. Hence it is desirable to improve handling by designing a stiffer or higher rate shock absorber, but this stiffness decreases the ride quality performance which is the sole purpose according to a consumer's point of view.

In the case of a passive system, a significant portion of the available suspension travel is used to take care of static load variations and of body roll caused by cornering, while in an Active Suspension system the passive force element is replaced or assisted by active force elements. These elements can produce a force when required and act independently of the suspension condition. The trade-off between ride comfort, suspension travel, and wheel load variations can be better resolved. Therefore, it is capable of reducing a vehicle's body roll during cornering and thus maintaining an optimal orientation of tires with respect to road.

## 1.1 METHODOLOGY

Our proposed suspension system works by changing the camber angle in real-time to the actual road conditions thus improving the steering and vehicle stability without compromising the ride comfort. In normal scenarios, an anti-roll bar is incorporated into the suspension to enable low rate springs. which provides ride comfort with a fair amount of ride handling.

From the literature review conducted, we had chosen a double-wishbone system as our primary suspension geometry. The main reason for choosing double-wishbone was its simplicity in varying camber angles, which is done by

varying the upper and lower control arm length. To specify the system parameters like camber caster toe roll center height etc., a passive double wishbone system has been developed and simulated on ADAMS/ CAR

Our proposed mechanism for varying camber includes an actuation system, which is attached to the upper control arm with the help of a bell crank mechanism which helps in good packing of the suspension system.

After a thorough study of various actuation systems, we had chosen electromechanical actuators. The major benefits of electromechanical actuators are its ability for controlling over the entire motion profile, heavy load capabilities, and high-speed actuation.

For analyzing the variations in the adaptive suspension system, an Openmodelica model was modeled. In our case, a standard simulation model is not available. Therefore, a model is developed on solid works. The model developed was imported to the Openmodelica and a PID controller was designed.

In order to demonstrate the active suspension system the working and planning to build a quarter model suspension test rig including the actuation system and a controller for varying the camber angels. Accelerometers are used to measure the parameters in order to control the actuation system.

**2. REVIEW ON PASSIVE SYSTEMS**

In order to study how the vehicle behaves in normal road conditions, a passive suspension system is considered. For that, the front suspension system of Alpha 3.0 was chosen. Alpha 3.0 was the 3rd generation ATV, which was designed and build in house by the team members of SAE TKMCE to compete for the SAE BAJA 19 competition held at IIT Ropar, Punjab.

**2.1 DESIGN CONSIDERATIONS**

**Table -1: Parameters of Alpha 4.0**

Parameter	Front	Rear
Ground Clearance	381 mm	368.3 mm
Track Width	1422.4 mm	1346.2 mm

- Wheel base: 1600 mm
- Tire: 23x8x10 inch
- Total mass: 230 kg
- Front mass: 103.5 kg
- Rear mass: 126.5 kg
- Sprung mass: 178 kg
- Unsprung mass: 52 kg
- Front sprung: 80.1 kg
- Rear sprung: 97.9 kg

**2.2 KINEMATIC AND COMPLIANCE TEST (K&C)**

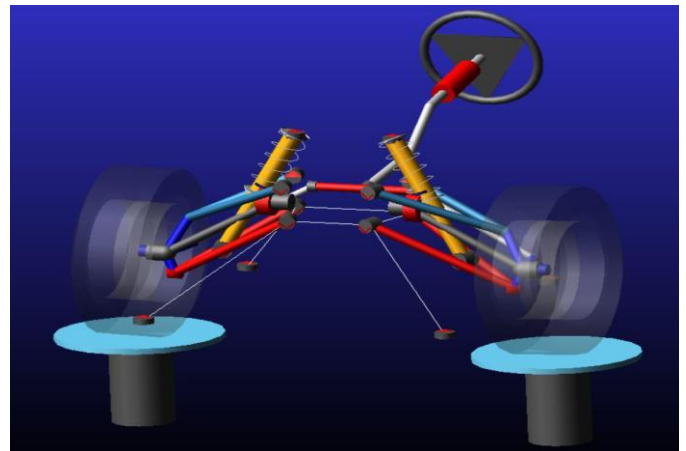

**Fig -1: Simulation Setup in MSC Adams.**

K&C is a special type of vehicle suspension testing in which measures suspension parameters both statically and dynamically as they change due to applied road height, roll angle, and horizontal forces. To simulate the K&C test ADAMS/ CAR software was used. A specific module of the chassis platform is developed to analyze suspension ride comfort on adaptability to different vehicles with ADAMS/Car. The work intention is to make a parametric ADAMS model and then link it to a Knowledge-Based Engineering application to facilitate designers to quickly carry out designing iterations in order to reduce development time. The Knowledge-Based Engineering software is made using an object-oriented language called 'Object Definition Language' which is developed using VC++ software languages. The module not only carries through parametric modeling of front and rear suspension and other subsystems of chassis quickly and compactly but also can carry on the analysis and optimization of various factors that have a crucial impact on ride comfort. The module offers two test-bend, vehicle virtual simulation test stands, and four-post-test rig.

loc_x	loc_y	loc_z	remarks	
hpl_drive_shaft_inr	0.0	-200.0	500.0	"(none)"
hpl_lca_front	-101.5	-123.666	457.2	"(none)"
hpl_lca_outer	0.0	-508.0	222.1	"(none)"
hpl_lca_rear	101.5	-177.8	457.2	"(none)"
hpl_lwr_strut_mount	0.0	-359.835	319.136	"(none)"
hpl_subframe_front	-400.0	-450.0	150.0	(none)
hpl_subframe_rear	400.0	-450.0	150.0	(none)
hpl_tierod_inner	175.0	-152.4	514.431	"(none)"
hpl_tierod_outer	150.0	-508.0	296.056	"(none)"
hpl_top_mount	40.0	-147.0	736.0	"(none)"
hpl_uca_front	-101.5	-135.0	579.0	"(none)"
hpl_uca_outer	40.0	-475.0	415.0	"(none)"
hpl_uca_rear	101.5	-177.8	571.0	"(none)"
hpl_wheel_center	0.0	-609.6	296.253	"(none)"

**Chart -1: Hardpoints of the Double Wishbone**

To model the suspension geometry for the test rig, hardpoints were calculated from the front geometry of the vehicle by

considering the ground clearance, track width, and side geometry features like anti-dive and anti-squat.

### 2.2.1 PARALLEL WHEEL TRAVEL

In this test, the wheel is actuated upward and downward for a certain amount of jounce and rebound. Here the jounce value applied is 177 mm and rebound as 127mm. During this test, the suspension parameters change depending on the geometry and the compliance of the suspension system. Various changes obtained from the post-processing window are

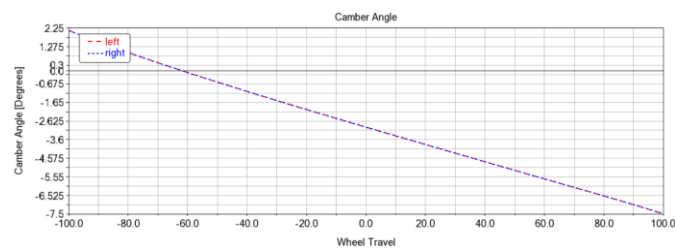

Fig -2: Plot of Camber angle vs wheel travel



Fig -3: Plot of Caster Angle vs Wheel Travel in ADAMS

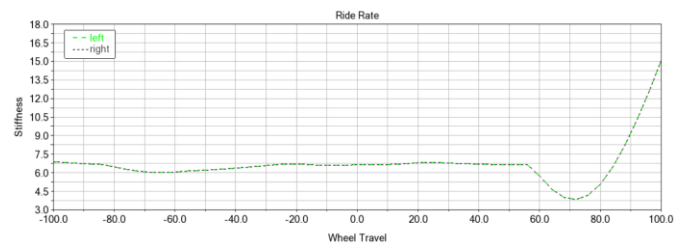

Fig -4: Plot of Ride Rate vs Wheel Travel in ADAMS

### 3. ADAPTIVE STRATEGY AND VALIDATION

Proposed active suspension system consists of a linear electromechanical actuator connected to the upper control arm of the suspension system. A bell crank mechanism is incorporated between the arms and the actuator to evenly distribute the actuator load and to improve the packing efficiency of the total mechanism which is crucial in automobile systems.

Linear electromechanical actuator is controlled by a control system which measures camber angle with the aid of a gyroscopic sensor placed on the knuckle and a PID controller triggers the actuator when the camber values go beyond the safe limits.

To analyze the active camber model, a simulation setup is developed for measuring various conditions and draw conclusions. In this case, a standard simulation model is not available.

Therefore, a model is developed on SolidWorks and simulated on Openmodelica. Openmodelica formulates and solves the equations of motion for the complete mechanical system. And to compare the results a passive system is also modeled on the Openmodelica.

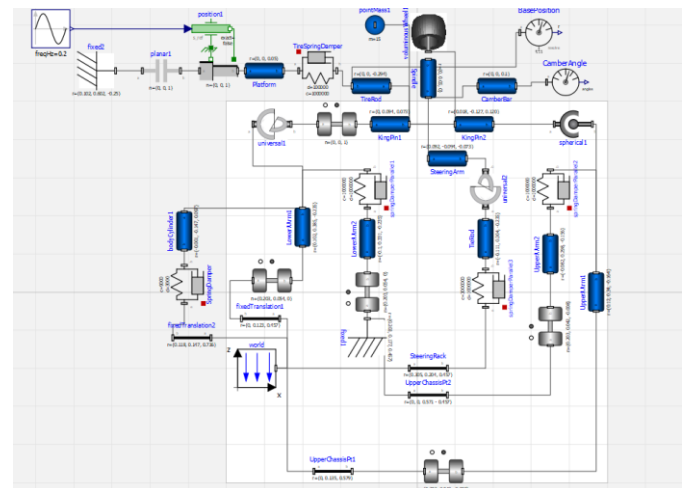

Fig -5: Openmodelica block diagram of Passive Suspension.

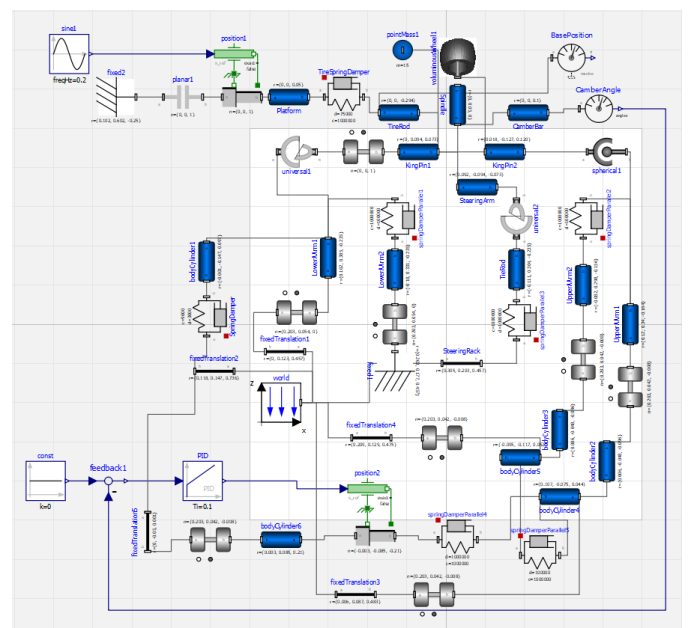

Fig -6: Openmodelica block diagram of Active Suspension

The blocks indicate the components of the system like the tire, spindle, knuckle, tie rod, lower arm, upper arm, the test rig and the jack. In the case of the adaptive model actuators and sensors are added. The sensors used in passive model are just for the acquisition of data and they do not modify the system. The input to the system is a sine wave road profile having bumps and potholes. The camber and toe angles are sensed using transform sensors in both the model. The PID controllers used in the adaptive model receive input signals

from the sensors, process the data and provide response signals to the actuators so that the camber and toe angles are brought to the desired values.

### 3.1 ANALYSIS OF PASSIVE AND ACTIVE SYSTEM

Passive and active suspension models generated with the help of openmodelica is simulated by giving road conditions. A road profile with bumps and potholes is given to the system using openmodelica models to simulate wheel travel and analyse the camber and toe characteristics of both the systems.

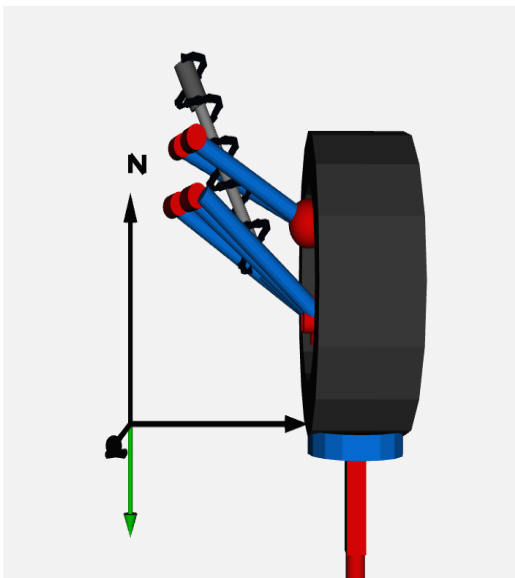

Fig -7: Physical model of Passive System in Openmodelica

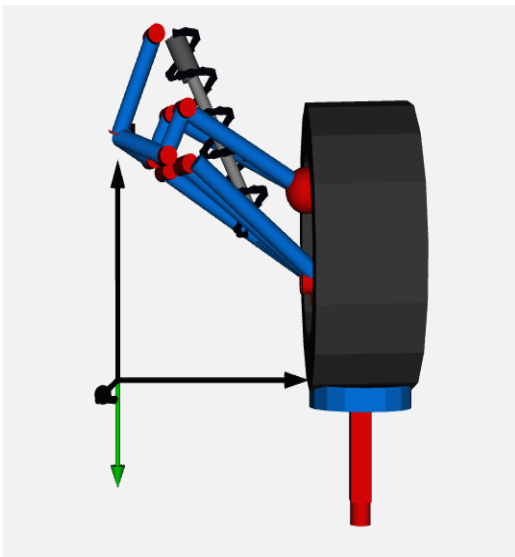

Fig -8: Physical model of Active System in Openmodelica

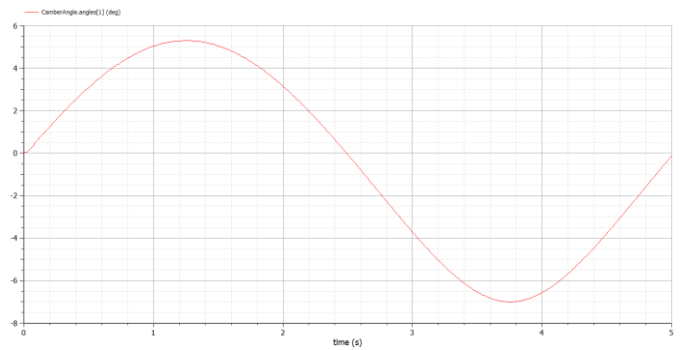

Fig -9: Plot of Camber Angle vs Time of Passive Model in Openmodelica

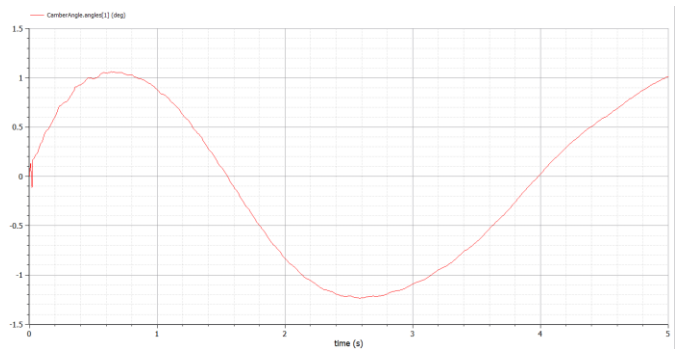

Fig -10: Plot of Camber Angle vs Time of Active Model in Openmodelica

### 3.2 ANALYSIS INFERENCE

On comparing the adaptive and passive systems, a substantial reduction of the camber and toe angle can be interpreted. The adaptive suspension system successfully manages to reduce the camber angle to 1.151° from 5.8°. This shows that the adaptive suspension system is successful in controlling the camber angles and thus improving the overall vehicle stability.

### 4. QUARTER CAR SUSPENSION TEST RIG

A quarter mass of vehicle suspension system is taken for the experiment and is referred to as quarter car suspension test rig. Proposed system consists of a double wishbone suspension, electric control unit, gyroscope and a linear electro-mechanical actuator. Double wishbone system consists of an upper-arm, lower-arm and OEM designed steering knuckle, wheel. A roller is introduced under the wheel as a cam to provide dynamic motion which resembles the bumps and irregular terrain conditions of the road on a real-time basis. This cylindrical shaped roller is made up of nylon material. Nylon with its stiff engineering plastic, bearing and wear properties is frequently used to replace metal bearing and bushings often eliminating the need for external lubrication. A reduction in part of weight, decreased wear and less operating noise allows nylon to be manufactured into different components like gears, sprockets and mainly rollers. A toggle clamp is also introduced to this roller from beneath, its lever is used to apply the clamping force, thus pushing against the workpiece when pressed upon. This allows specific terrain conditions, specific angles to be worked upon without practical implementation.

Camber adjustment and alteration is done with the help of the gyroscope sensor placed on the knuckle whilst real time data is preassigned and fed through a PID controller to obtain the desired result. A linear actuator is preferred to provide a controlled linear displacement at the upper arm of the fulcrum axis., actuation is done and the tire returns to its programmed position irrespective of the road profile. These actuators are preferred because they can provide a clean operation, motion and force control within a desirable price range. Adjacent to this actuator lies the bell crank which is an 'L' Shaped lever pivoted at its centre, the direction of the input movement or force would be turned through 90° at the output end. Now specifying the masses, tire and axle forms the unsprung mass and the rest of the quarter model is the sprung mass.

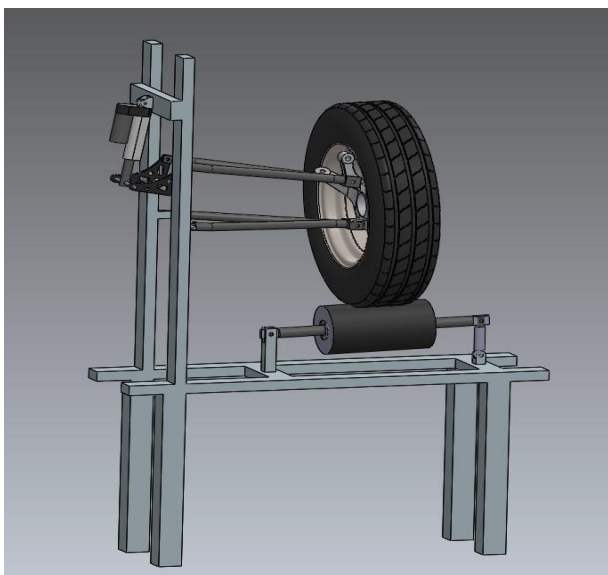

Fig -11: Prototype of Quarter Model.

**4.1 MULTIBODY ANALYSIS OF THE PROPOSED MODEL IN MSC ADAMS**

Solid model modelled created in solid works is imported to ADAMS and relations between the parts in setup based on the proposed strategy and a simulation is performed by giving step functions to various joints and parts.

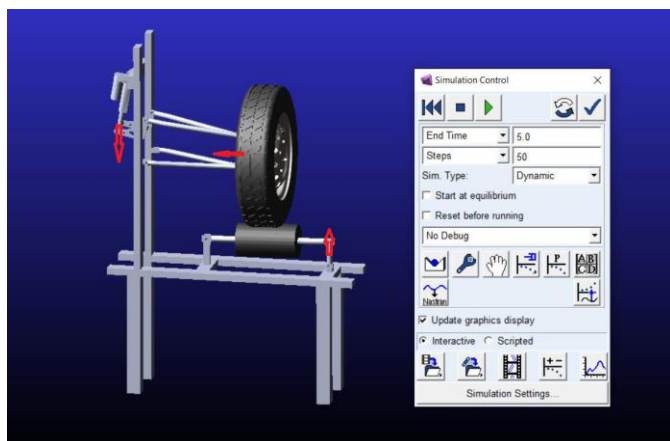

Fig -12: Setup for simulation in ADAMS.

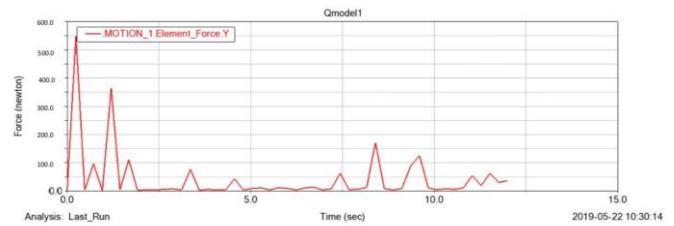

Fig -13: Plot of actuation force vs time.

From the results obtained in the dynamic simulation, compatibility of mechanism is validated and the load acting on the actuator is determined. On the basis of this result an actuator is selected for actuation with a load capacity of 1000N.



Fig -14: Fabricated Quarter model suspension test rig.

**5. CONCLUSIONS**

An adaptive suspension system was developed in this project to improve the performance and maneuverability of vehicles during intense turning scenarios. This is accomplished by increasing the lateral tire force capability by introducing an active camber suspension system coupled to the upper control arm. A gyro sensor was implemented on the wheel upright to measure camber gain during intense cornering and a control strategy was developed using a PID controller which senses the camber gain and generates a signal to trigger the electromechanical actuator. To study the varying parameters a passive system was studied. From the study conducted, the camber angle was identified as one of the major attributes for roll-over. Then a quarter model was developed in Solidworks and was imported to Openmodelica, the passive and active system was simulated in it. The camber angle variation was more in the passive system compared to the active system. A quarter rig was fabricated with a double-wishbone suspension system, and a varying upper control arm coupled with a linear actuator to control the camber gain. The advantage of the proposed system over other systems is that it involves less complexity, ease of application,

reduction of expenses, and power requirement. This system would also help in increasing wheel travel without compromising camber characteristics. In the future, research will be focused on refining the method with non-linearity and also complex control mechanisms to improve the smoothness in the response of the particular system.

#### REFERENCES

- [1] Gillespie, T. D. **(1994)**. Fundamentals of Vehicle Dynamics. Society of Automotive Engineers.
- [2] Heisler, H. **(2002)**. Suspension. Advanced Vehicle Technology.
- [3] Jazar, R. N. **(2018)**. Vehicle Dynamics Theory and Application. Cham: Springer International Publishing.
- [4] Kavitha, C., Shankar, S., Ashok, B., Ashok, S., Ahmed, H. and Kaisan, M. **(2018)**. Adaptive Suspension Strategy for a Double Wishbone Suspension Through Camber and Toe Optimization. Engineering Science and Technology, an International Journal, 21(1), 149-158.
- [5] Milliken, W. F., **(1995)**. Race car vehicle dynamics. Society of Automotive Engineers.
- [6] Németh, B., Fényes, D., & Gáspár, P. **(2016)**. Independent wheel steering control design based on variable-geometry suspension. IFAC-PapersOnLine, 49(11), 426-431.
- [7] Pan, H., Sun, W., Jing, X., Gao, H., & Yao, J. **(2017)**. Adaptive tracking control for active suspension systems with non-ideal actuators. Journal of Sound and Vibration, 399, 2-20.
- [8] Roethof, D., Sezer, T., Arat, M., and Shyrokau, B., **(2016)**. Influence of Active Camber Control on Steering Feel. SAE Int. J. Passeng. Cars - Mech. Syst. 9(1), 01-0466.
- [9] Sert, E. and Boyraz, P. **(2017)**. Optimization of Suspension System and Sensitivity Analysis for Improvement of Stability in a Midsize Heavy Vehicle. Engineering Science and Technology, an International Journal, 20(3), 997-1012.
- [10] Shao, X., Du, H., and Naghdy, F., **(2016)**. Enhanced Vehicle Handling and Ride through Anti-Pitch Anti-Roll Hydraulically Interconnected Suspension. SAE Technical Paper, 01-1561.