

Development of Side-Stand Retrieval Mechanism for Two Wheeler Motorcycle

More Sushant S.¹, Jadhav Malhar A.¹, Takalkar Atul S.²

¹Student, Department of Production Engineering, Kolhapur Institute of Technology's College of Engineering, Kolhapur, India

²Assistant Professor, Department of Production Engineering, Kolhapur Institute of Technology's College of Engineering, Kolhapur, India

Abstract - Nowadays, the percentage of two-wheeler motorcycle accidents is increased due to the ignorance of the driver. Mostly the ignorance is observed in not removing the side stand before starting the two-wheeler motorcycle. The present study deals with the development of the side stand retrieval mechanism for a two-wheeler motorcycle to avoid accidents. The present study deals with the utilization of the chain sprocket mechanism with the attachment of the arm to retrieve the stand. The developed product will help to retrieve the stand automatically before the two-wheeler come into the motion.

Key Words: Side stand, Retrieval mechanism, Accident reduction, Two-wheeler vehicle

1. INTRODUCTION

According to a sales survey conducted by Statista [1], the sales of two-wheelers for the fiscal year 2017-18 were around 20 million units for the top six OEMs and is expected to grow surpassing China to claim the first position in two-wheeler sales. Still, the rates of accidents caused by these vehicles are significant. The road accidents for different types of vehicles observed in the year 2016 is shown in Fig. 1. The number of non-fatal accidents injured about 1,53,060 people in 2016, and the major reason for such kinds of accidents is carelessness while riding the vehicle, which includes forgetting to retrieve the side stand or not following the safety regulations [2].

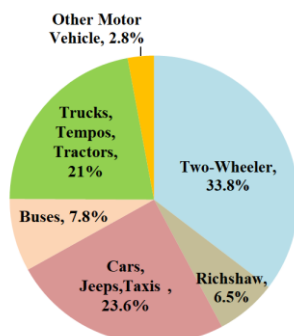

Fig -1: Road accidents for different types of vehicles in the year 2016 [2]

The problem may be small, but a considerable amount of accidents are caused due to these reasons. In India, about 22

% of accidents were observed to be occurred due to ignorance in lifting the side stand.

2. LITERATURE REVIEW

Gowtham et al. [3] proposed the system which automatically retrieves the stand by using chain drive, whereas the device was proposed by Muralidharan et al. [4] to raise the stand while running of the motorcycle. Similarly, the separate attachment had been provided for the lifting of the stand automatically [5, 6, 7]. The side stand retrieval system was developed by using sprocket [8, 9] and spring [10], which can help to reduce the accidents. The design and fabrication of the automatic side-stand retrieval system were carried out by a few authors. The designed setup was mounted between the chain drive, which rotates and helps to automatic retrieval of stand [11, 12]. Few designs were fabricated, which operates totally by means of manual feet power of the rider. Along with the design, few authors had also carried out the analysis of side stand mechanism using finite element software [13, 14].

Elimination of such kinds of accidents can be achieved by introducing additional safety devices to the vehicles, which will not only enhance the riding quality but also acts as a safeguarding device for the rider. This can be achieved by implementing the mechanism for retrieving side stand, which consists of minimum addition of components in an already existing transmission system of a two-wheeler.

3. MATERIAL

The components used in the development of the mechanism are of different materials as per their functionality. The major elements utilized in the mechanism are shown in Table 1 with their respective material.

Table -1: Elements in the proposed mechanism with their material

| S.N | Component | Material |
|-----|----------------------------|------------------|
| 1 | Rear wheel sprocket | Low Carbon Steel |
| 2 | Final drive sprocket | Low Carbon Steel |
| 3 | Chain | Alloy Steel |
| 4 | Lifting and sprocket lever | Mild Steel |

4. CONCEPT

In the present working two-wheeler motorcycles, the power is delivered to the rear wheel through a transmission train, which utilizes a chain sprocket mechanism for the efficient transmission of power and torque. [2]

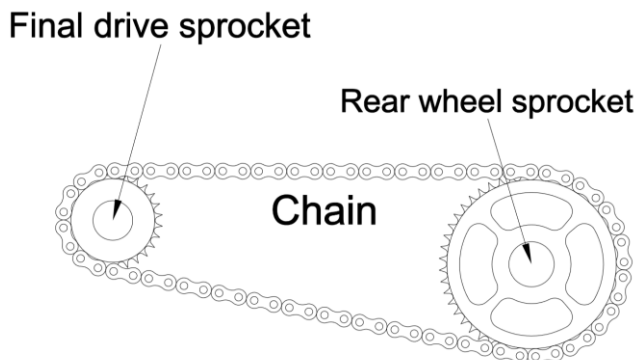

Fig -2: Transmission mechanism in two-wheeler vehicle [2]

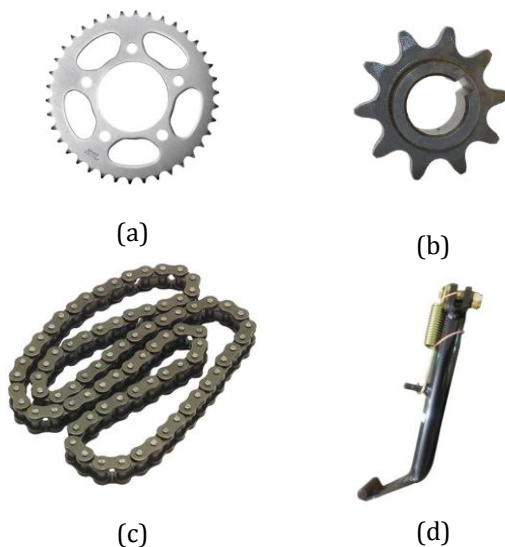

Fig -3: Elements in the proposed mechanism, (a) rear wheel sprocket, (b) final drive sprocket, (c) chain, (d) side-stand [2]

The transmission train commonly adapted for Indian two-wheelers consists of different elements, as shown in Fig. 2. The final driving sprocket at the end of gearbox generally transmits the drive from the gearbox to the rear wheel sprocket mounted on the rear wheels of a two-wheeler

through an overrunning chain. [2]

The proposed mechanism utilizes the components available in the secondary drive system of power transmission train, which includes rear wheel sprocket, final drive sprocket, chain, and side-stand as shown in Fig. 3. Along with these components, the transmission train consists of levers, and the extra drive sprocket is shown in Fig. 4.

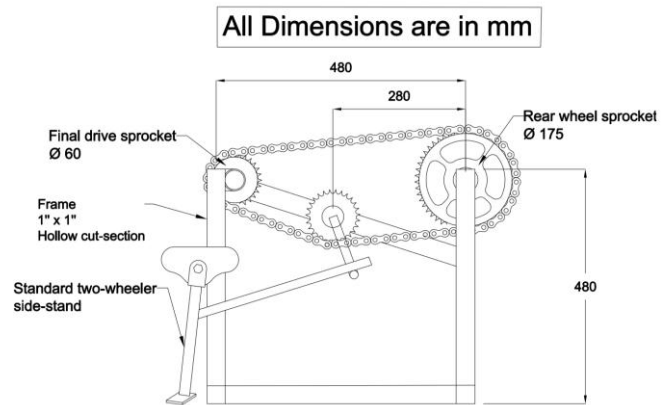

Fig -4: Dimensions of the proposed side stand retrieval mechanism [2]

5. RESULT AND DISCUSSION

The constructional feature for the proposed mechanism includes a sprocket situated in the transmission train in between the final drive sprocket and rear wheel sprocket along with a lever mounted on the periphery of the sprocket. Similarly, a lever welded on the side stand act as lifting lever, as shown in Fig. 5.

When the vehicle is in the parked condition, the lever welded to the side stand rests over the sprocket lever. This condition will prevail whenever the vehicle is rested on the side stand. When the vehicle is to be set in motion, the elements of the transmission train will receive the power along with the sprocket set in between the driving and driven sprocket. The rotation of the sprocket will cause the lever to push the side stand lever in an upward direction, and the rest of the work required to retrieve the side stand is done by the spring tension present in the side stand. As the stand gets retrieved, the contact between both the levers gets diminished. [2]

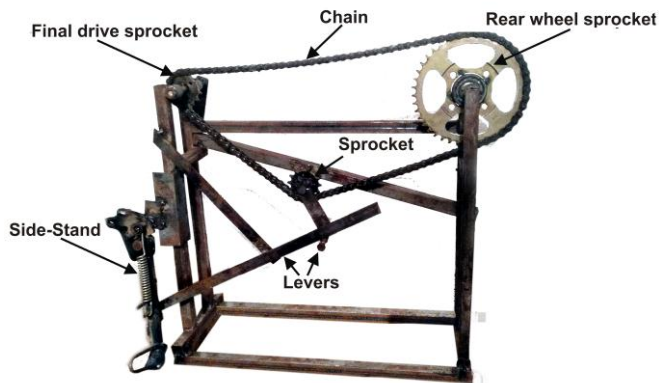

Fig -5: Proposed model of the side stands retrieval mechanism

The experimental setup of the proposed mechanism is observed to be fulfilling the requirement of retrieval of the side stand. The limitations which were observed while constructing the mechanism can be overcome by further development. The position of the sprocket in the chain is a convoluted part that has to be handled properly with a mathematical approach as the position of the sprocket will determine the length of the side stand to lift lever which has to be minimum as possible to fit in available space present in the vehicle. The placement of the sprocket in the proposed mechanism is on the frame itself, which provides it sturdy support, but while considering a two-wheeler, such space is difficult to identify. Thus the construction of the extra frame feature in the vehicle needs the support of the sprocket.

6. CONCLUSIONS

Although the accidents caused by the extended side stand while riding is a sign of carelessness but the accidents caused due to this reason is considerably high in percentage. This can be overcome by implementing the modified chain sprocket mechanism in a two-wheeler motorcycle for effortless and accident-free riding. The implementation of the proposed mechanism can be utilized in the heavy two-wheelers vehicles used for the carrying heavy load by the farmers where the retrieval of the side stand is difficult when fully loaded.

The new drivers often forget to retrieve the stand, which can lead to an accident. The new rider can't handle such a situation properly; thus proposed retrieval mechanism ensures the safety of driver and people in the surrounding. Further, the development in the mechanism can be made by the introduction of the sensors and electronic control over the system with the mechanism which can be shrunk down for an easy installment in all sorts of two-wheelers.

ACKNOWLEDGEMENT

This work was supported by Bhavani Ironchem Technologies Pvt. Ltd., Kolhapur, India.

REFERENCES

- [1] Article from statista.com, "Two wheelers sales in India from 2010/11 to 2017/18".
- [2] Road accidents in India – 2016, Government of India ministry of road transport & highways transport research wing, New Delhi.
- [3] K.Gowtham, G.Gokulnath, K.Jeevanandhan, C.Senthilraja, L.Vinoth, "Automatic Side Stand Retrieves System", International Journal of Innovative Research in Science, Engineering and Technology, ISSN: 2319-8753, Vol. 4, Special Issue 13, December 2015.
- [4] Bharaneedharan Muralidharan, Ranjeet Pokharel, "Automatic Side Stand Retrieve System", Indian Journal Of Research, ISSN - 2250-1991, Volume: 3, Issue: 2, Feb 2014.
- [5] Achinta Mandal, Sai Kiran Velgada, Sanjay Kumar Sabat, Kamlesh Kumar, Medimi Dinesh, "Automatic Side stand retrieval System", International Journal of Scientific Development and Research, ISSN: 2455-2631, Volume 2, Issue 4.
- [6] Pravin Barapatre , Pushpak Manmode, Prashant Khadatkar, Pratik Das, Dhawal Bante, Saurabh Dangore, Sanket Bure, "Automatic Side Stand Lifting Mechanism", ISSN: 2278 – 7798 International Journal of Science, Engineering and Technology Research (IJSETR) Volume 5, Issue 4, April 2016.
- [7] Amit Singh, Ankit Kumar Rai, Chandan Yadav, Jayhind Yadav, Prasoon Choudhary, "Automatic Side Stand of two wheeler", International Research Journal of Engineering and Technology, ISSN: 2395-0056, Volume: 05 Issue: 04, Apr-2018.
- [8] Suthar Nirav, Patel Bhavin, Patel Shrijay, Vikram Panchal, Jayesh Patel, "Proposed Work on Sprocket Side Stand Retrieve Mechanism in Two Wheeler Vehicle", International Journal for Scientific Research & Development, ISSN: 2321-0613, Vol. 5, Issue 06, 2017.
- [9] Pintoo Prjapati, Vipul kr. Srivastav, Rahul kr. Yadav, Ramapukar Gon,Pintu Singh, Mr. Sandeep, "Sprocket Side Stand Retrieve System", International Journal of Technical Research and Applications, PP. 86-87, ISSN: 2320-8163, Volume 3, Issue 3, May-June 2015.
- [10] Gowthaman.S.M, Muruga Poobathi.K, Vasu.N, Mohan Kumar.N, "Fabrication of Side Stand Accident Free Element", International Journal of Scientific & Engineering Research, ISSN 2229-5518, Volume 7, Issue 5, May-2016.
- [11] Dr.J.Hameed Hussain, Durairaj V. P, "Design and Fabrication of Automatic Side Stand Retrieve System", International Journal of Pure and Applied Mathematics, 357-362, ISSN: 1314-3395, Volume 116 No. 14 2017.
- [12] Aniket Gulhane, Ganesh Gawande, Bhagwat Gawande, Shraddha Dhule, Chaitanya Deshmukh, "Fabrication of Automatic Side Stand Lifting Mechanism", International Journal of Emerging Technologies in Engineering Research, ISSN: 2454-6410, Volume 5, Issue 4, April 2017.

- [13] Suresh. K, Afrin Hewitt. A, Mohammed Salman. N, "Design and Analysis of Safety Side Stand For Motorcycle", International Journal of Advanced Research in Management, Architecture, Technology and Engineering", ISSN: 2454-9762, Vol. 2, Special Issue 6, March 2016.
- [14] Ankitkumar K. Shriwas, Vidyadhar C. Kale, K. V. Chandratre, "Design and Analysis of Standing Device for Two Wheeler", International Engineering Research Journal pp. 361-371.