

Power Generators using Automatic Transfer Switch

Kiran S. Nistane¹, P. V. Raut²

¹Student, Dept. of Electrical Engineering, DES'S COET, Dhamangaon Rly

²Professor, Dept. of Electrical Engineering, DES'S COET, Dhamangaon Rly

Abstract -

To enable the automatic operation and transfer of power supply between a public utility supply and a power generator an Automatic Transfer Switch for a single phase power generator has been designed. The main source of power supply distress is allowable by means of an automatic connection to a network of other sources of supply. The automatic transfer switch which is a switchgear control system, provides a functional system that offers an automatic switching of power supply between a primary source and secondary source is generator. This paper presents a real laboratory design and construction of Automatic Transfer Switch (ATS) with three phase selector. The design method involves the use of electromechanical type relays, and comparators, etc. The ATS designed demonstrates its ability to perform automatic power change over activities easily without any human interaction.

Key Words: Automatic Switching, Automatic Transfer Switch, Delay Timer Relays, Relay, Voltage Monitoring Relay.

1. INTRODUCTION

Automatic changeover switch is an indispensable piece of the procedure of intensity age, permitting smooth and moment move of electric flow between different sources and burden. The capacity of the programmed change over switch is to screen the approaching open gracefully voltage and distinguish when the voltage dips under a specific level that electrical/electronic apparatuses can work contingent upon the utility flexibly. The programmed change over switch looks at the voltage of the other two stages utilizing a comparator circuit and if the voltages are not accessible, the framework changes over from open flexibly to generator. At the point when the generator is in activity, the exchange switch forestalls any criticism current to the heap. It additionally guarantees that the distinctive force sources are synchronized before the heap is moved to them. The exchange switch detects when there is interference if the mains flexibly stays missing.

An exchange switch is an electrical switch that reconnects electric force source from its essential source to a backup source. Switches might be physically or consequently worked. An Automatic Transfer Switch (ATS) is regularly introduced where a reinforcement generator is found, with the goal that the generator may give brief electrical force if the utility source falls flat. An ATS not just securely switches-in the reinforcement generator as a transitory wellspring of

electric force; it likewise orders the reinforcement generator to begin, in light of specific conditions it ceaselessly screens on the essential feed. The exchange switch secludes the reinforcement generator from the electric utility, when the generator is on and is giving brief force. The control ability of an exchange switch might be manual just, or a blend of programmed and manual. The switch progress mode (see beneath) of an exchange switch might be Open Transition (OT) (the typical kind), or Closed Transition (CT). An Automatic exchange switch (ATS) is an electrical/electronic switch that detects when the mains or open utility gracefully is hindered and consequently fires up an optional flexibly (for example a generator) if the utility stays inaccessible. ATS otherwise called "Generator Transfer Switches, has an extra circuit part which is typically as a PC that screens the approaching force flexibly. This circuit as per Silva and Kolo, likewise screens the voltage lists, power floods, power spikes, or brownouts. It likewise starts the changeover activity when there is a finished force misfortune. At whatever point a flaw is been recognized, the programmed move switch fires up the crisis power gracefully. The ATS is associated with both force gracefully sources and supplies the heap with power from just one of the sources at a specific moment in time.

They are a lot of like voltage screens that screen approaching force a lot of like an indoor regulator and a soon as the force level falls beneath certain edge indicated by the client it turns on the reinforcement power. They are generally used to switch between:

1. One generator to another: Systems that utilization various generators as the prime force source.
2. Utility capacity to generator: These including offices that have both utility and salary force and uses generators for reinforcement as it were.

The exchanging system of the generator is finished with a 12V d.c flexibly battery and helper contacts of the clock transfers and the contactor. The programmed start and halting of the generator relies upon whether the contactors are stimulated and de-empowered. Show unit was additionally planned. The advanced multimeter (DMM) showing the yield voltage and the appraised current of the ATS have a 12V and 5V d.c power gracefully unit (PSU), a present transformer (C.T), an ADC microcontroller (PIC 16F877) to change over the deliberate simple a.c voltage and current to computerized esteems for show on the fluid gem show (LCD) show.

2. RELATED WORK

2.1 Size Selection of Transfer Switch

On the off chance that you need to run your whole burden if there should arise an occurrence of a force blackout, and you have an enormous enough generator, you need an exchange switch that is a similar rating as your primary breaker board. For a home this will regularly be either 60A or almost certain 200 amps. The exchange switch would be introduced between your fundamental breaker (ordinarily at the meter) and your primary electrical board. On the off chance that you need to run just certain heaps during a force blackout you can introduce a sub board (EMDB) off of your primary board and utilize a less amper move switch rely upon the heap. This is an extraordinary thought in the event that you don't have a generator sufficiently large to run everything.

2.2 Automatic transfer switch components

There are three (3) basic components of a transfer switch:

1-Power changing gadget to move the heap circuits to and from the force source (contactors, changeover, or Circuit breakers).

2-Transfer Logic Controller to screen the state of the force sources and give the control signs to the force exchanging gadget.

3- Control power source to gracefully operational capacity to the controller and exchanging gadget (battery).

2.3 Modes of operation Manual Mode:

The module is set into Manual mode by squeezing hand/auto button. Manual mode is utilized for control the ATS physically and to begin and halting the generator motor. AUTO Mode: The module is put into auto mode by squeezing hand/auto button. In the event that a mains disappointment on any stage is distinguished after the mains disappointment defer clock lapses, the heap is turned off from the mains and the ATS unit will consequently give a beginning order to the genset controller by utilizing the parameters settings. At the point when the generator works inside the limits the heap is moved to the generator by the ATS module. When the mains gracefully has been reestablished after the mains progress postpone clock terminates, the ATS module will move the heap over from the generator to the mains flexibly and expel the beginning order from the genset controller after the cooling time. In the event of a disappointment while working, the unit will stop the generator naturally. An unmistakable copy outline and LEDs give data about the heap status and voltages.

3. METHODOLOGY

The A.C voltage observing and control circuit are planned and built. This was accomplished by utilizing voltage checking hand-off (VMR) as an essential segment of the force detecting and control circuit; which is utilized for estimating and contrasting the voltage level of the utility gracefully with a set voltage resistance go (185-250V A.C) while a 12A smaller than usual electrical switch will go about as a change to the force flexibly from the open utility finish of the ATS. The force exchanging circuit was structured. ABB-type power contactors appraised 12A, 220V a.c, clock transfers to give a few postponements (5 seconds) during the beginning of the generator and move of the associated load the other way around from the both force sources relying upon the side with consistent electrical force anytime are utilized.

3.1 The Relay switching stage:

This block consists of the combination of the voltage monitoring relay (VMR) and the finder relays (11-pin relays) which serve as sensor used to determine the availability or non availability of voltage supply from either power sources before triggering the control sections of the ATS. The VMR is used for measuring and comparing the voltage level of the utility supply with a set voltage tolerance range (185-250V A.C).

3.2 The Timer relay Stage:

This block is made up of delay timer relays operating as normally open timed closed (NOTC) timer relays on each section of the ATS. The Timer relay on the utility section helps to delay the supply of electric power from the public utility, thus preventing the occurrence electrical damage due to fluctuations in voltage supply. The Timer relay on the GENERATOR section helps stabilize the power generator and allows it to warm up before it finally supplying power to the connected load. The delay time for the utility timer relay is 5-6 seconds while that of the generator is about 10 seconds.

3.3 The contactor switching stage:

This block is made up of Contactors on each side of the ATS (i.e. the utility contactor (KN) and the generator contactor (KG)). The function of the contactor is to switch the current to the connected loads easily. This is because they are made to handle large amount of current flow in electrical installations. The maximum load rating of the contactors is 12Amps.

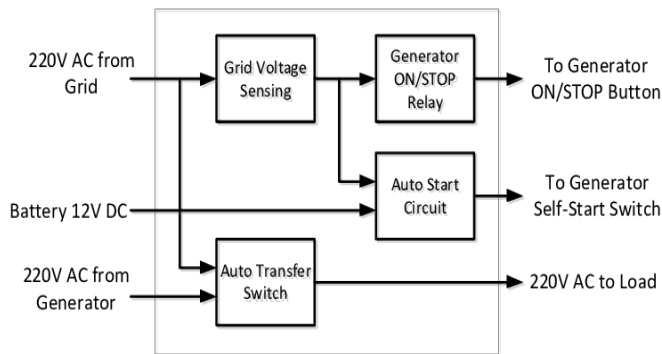

Fig.1 Block Diagram of Automatic Transfer Switch

4. CONCLUSION

Automatic Transfer Switch has been planned and built. The model of the framework worked by determination and very palatable. The programmed stage change-over switch is moderately reasonable and dependable. It is anything but difficult to work, and it gives a significant level of intensity gracefully when there are power blackouts. At long last, it diminishes pressure related with manual change-over. Be that as it may, for future work. The programmed move exchanging circuit had the option to switch between the two force gracefully sources as per the set need and furthermore consequently turns on the generator and switches it off. The task has been demonstrated to be entirely dependable and can be conveyed in houses, workplaces, modern settings and all conditions where steady force flexibly are vital.

REFERENCES

- [1] M.S Ahmed, A.S Mohammed and O.B. Agusiobo, "Development of a Single phase Automatic Change-Over Switch", Department of Electrical and Computer Engineering, Federal University of Technology Minna, Nigeria, July 2006.
- [2] R. Silva, "How automatic transfer switches work", retrieved online from http://www.articlesbase.com/tool_and equipments. November, 2009.
- [3] J. G. Kolo, "Design and Construction of a Single Phase Automatic Change-Over Switch", Department of Electrical and Computer Engineering, Federal University of Technology Minna, Nigeria, 2007.
- [4] ATS-01 Ver1.0, Automatic transfer switch control unit operator's manual: retrieved on December 17, 2009.
- [5] Ezema L.S, Peter B.U, Harris O.O, "design of automatic change over switch with generator control mechanism", Electrical Power and Electronic Development Department, Projects, Development Institute (PRODA), Enugu, NIGERIA, November 2012.
- [6] Jonathan Gana Kolo (2007). Design and Construction of an Automatic Power Change over Switch. AUJ. T. II (2): 113 – 118 (October 2007).
- [7] Theraja, B.L.; and Theraja, A.K. 2002. Electrical Technology, 21 st ed. Ranjendra Ravida, New Delhi, India.