

# Traffic Synchronization using Smart Signals

Gaurav A. Deshpande<sup>1</sup>, Mayuresh N. Joshi<sup>2</sup>, Archit Saraswat<sup>3</sup>, Sumedha Sirsikar<sup>4</sup>

<sup>1,2,3</sup>Final Year Student, Department of Information Technology, MAEER's MIT Pune, Maharashtra, India

<sup>4</sup>Head, Department of Information Technology, MAEER's MIT, Pune, Maharashtra, India

\*\*\*

**Abstract** - Over the last few years, growing urbanization and increase in the number of vehicles has significantly increased traffic congestions on roads. People need to travel longer distances within minimum possible time. While the current traffic signal systems in place based on pre-configured green time schedules are inadequate to handle the randomness in traffic densities and efficiently distribute the traffic, 'Traffic Synchronization using Smart Signals' is a system that tries to efficiently manage and reduce the increasing amount of traffic congestion in urban areas through adaptive signals, a method that manipulates the traffic signal timer based on the real time continuously varying traffic density, thereby increasing efficiency of the traffic signal to distribute traffic and also achieve synchronization such that maximum number of vehicles pass through with minimum stopping time.

**Key Words:** Traffic, Synchronization, Adaptive, Smart Signals, efficiency.

## 1. Introduction

In a rapidly developing fast paced world, Traffic Congestion has become a major problem across urban areas. Long vehicular queues, longer travel times, wastage of fuel and reduced services have become common. A study by the Boston Consulting Group (BCG) in April last year estimated that severe road congestion in the four big cities of Delhi, Mumbai, Kolkata and Bengaluru added up to \$22 billion in congestion costs.

Long vehicular queues result in longer travel times and wastage of fuel and other resources.

Current Traffic Management Systems in place are not efficient in dealing with randomness in traffic densities across different places at different times.[1]

An exponential increase in traffic congestions due to increase in urbanization, increase in the number of cars, out of sync signals and inefficient town planning in urban areas resulting in longer travel times, wastage of fuel, degradation of environment and frustration amongst the public demands efficient ways to counter the inefficiencies of the current traffic management systems [3].

According to a report by office commute platform MoveInSync Indians spend 7% of their day in commuting to office, averaging less than 3 minutes per kilometer. 'Travel Time Report Q1 2019 vs Q1 2108' report is based on the data collated from the rides on MoveInSync platform across Bengaluru, Hyderabad, Chennai, Pune, Mumbai and Delhi-NCR.

City wise, the report found that office commuters in Chennai travelled the fastest with a speed of 25.7 km/hr, while Bengaluru and Mumbai travelled the slowest with an average speed of 18.7 and 18.5 km/hr. Hyderabad and Delhi-NCR travelled at 21.2 and 20.6 km/hr respectively.

The average travel speed across 6 cities indicates that India's IT corridor takes 2 minutes and 26 seconds to cover a distance of 1 km. The same is shown in Figure1.

This study shows that there is high traffic congestion in these cities. This can be reduced by using traffic signal synchronization.

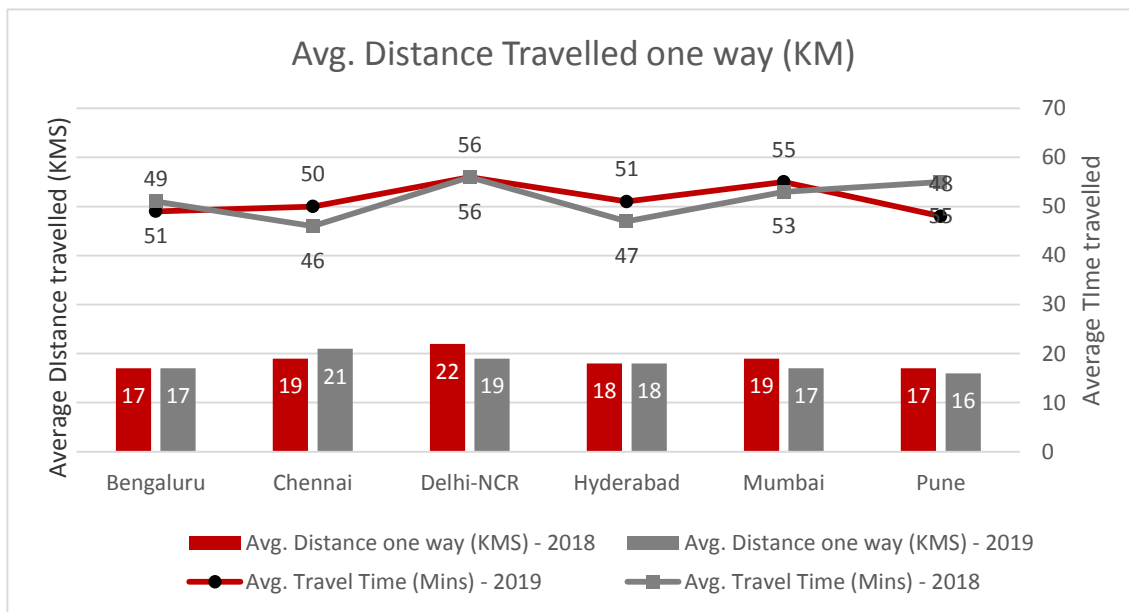

Figure 1. Time Distance statistics

The goal of synchronization is to get the greatest number of vehicles through the intersection with the fewest stops. It would be ideal if every vehicle entering the system could proceed through the intersection without stopping.

A system based on adaptive signals that can manipulate the traffic signal counter based on the traffic density can be of great relief in ensuring efficient distribution of traffic and its synchronization such that maximum number of vehicles can pass through with minimum number of stops. Signal synchronization will result in reduction in travel time and thus reduce traffic congestion.

### 1.1 Traffic Synchronization using Smart Signals

“Traffic Synchronization using Smart Signals” an IoT/Embedded system that shall receive real time inputs from the vehicles passing from where the system is installed and based on multiple parameters the signals programmed in such a way that they can manipulate the signaling counter to efficiently manage the randomness in traffic densities at different places at different times. Each traffic signal at an intersection embedded with a small IoT/Embedded system with computational and communication capabilities and be

using a master slave architecture for operation and coordination between all the traffic signals at a location where master responsible for acquiring real time data from all sources and deciding the order / time of distributing the traffic.

This paper proposes a solution to effectively manage and reduce the amount of traffic congestion through adaptive signals, a method that manipulate traffic signal timer based on real time continuously varying data unlike the traditional approach of fixed time signals. The system flow is presented in detail followed by detailed system architecture and implementation and deployment approach. The various risk associated are also elaborated along with scope for further research.

### 2. Proposed Solution

The proposed solution for Traffic synchronization involves sensors that collect real time data from the intersection that has the smart signals installed. Based on the density of cars, the width of the road, and the average speed of each lane, the time slice for each signal to turn green is calculated. Figure 2 shows the generic diagram of the system.

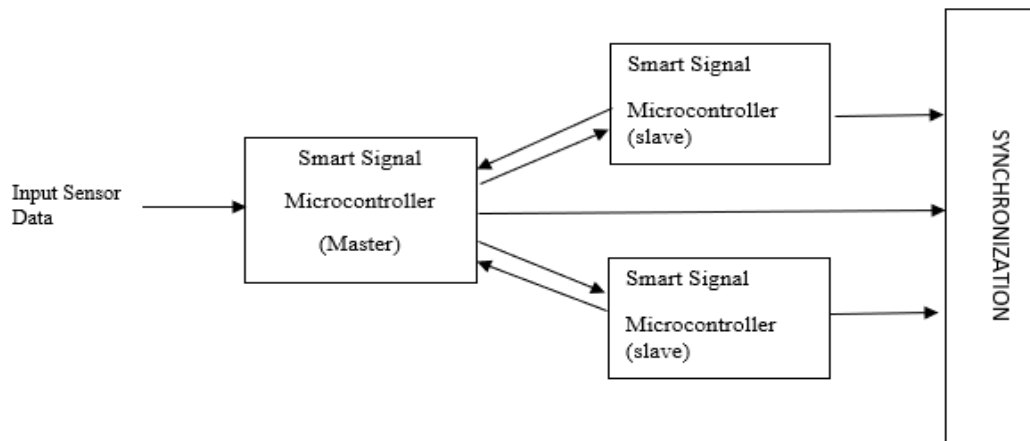

Figure 2. System Block Diagram

The system is indirectly used by the people driving vehicles as it does not get direct input from them. But their presence on a road adds to the traffic density input that is to be used by the system. The state transport department shall directly

use the system, for their goal of traffic control. The transport department shall be responsible for installation and maintenance of smart signals.

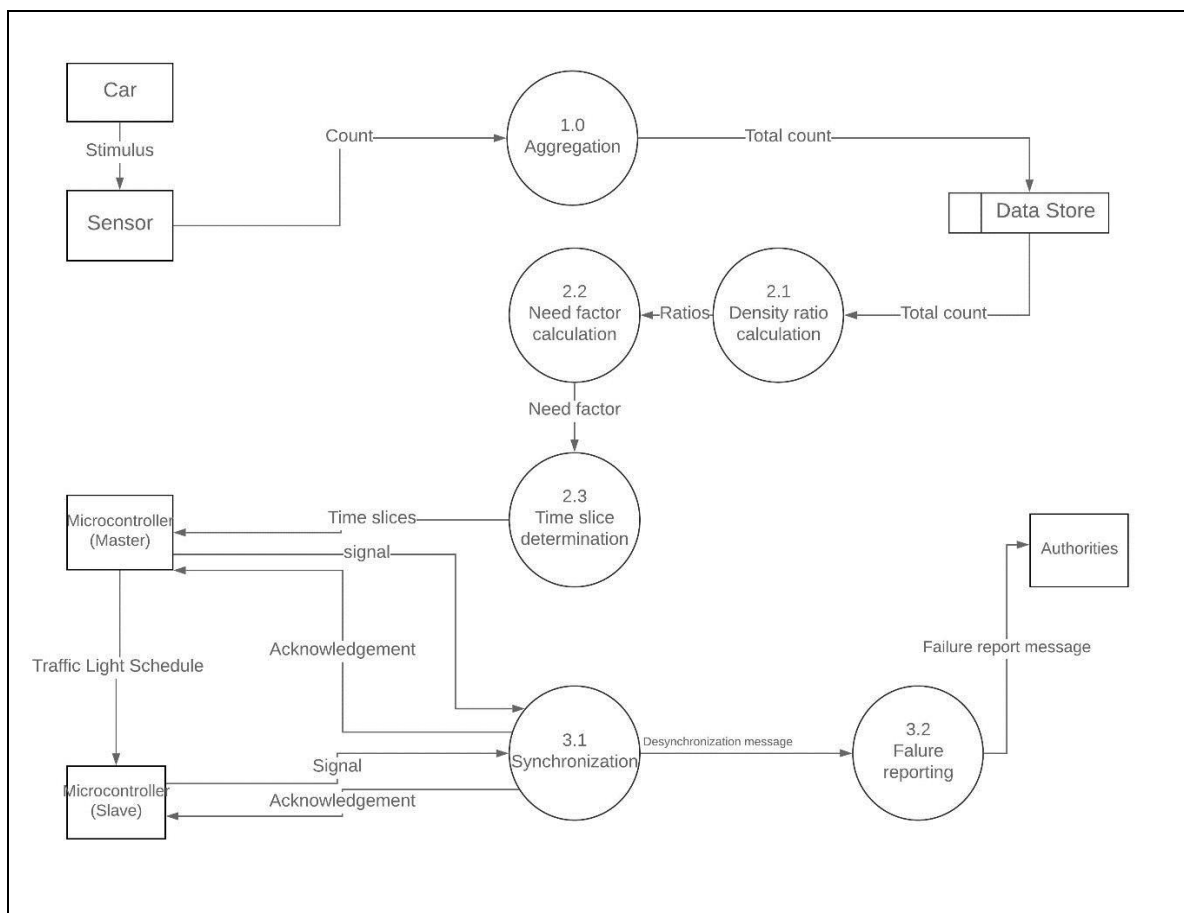

Figure 3. System flow Diagram

Figure 3. explains how data flows across the entire system. All the signals in the system will be synchronized so as to not allow any moment where there are multiple green signals at a single cross section.

Multiple kinds of sensors namely magnetic sensors / passive infrared / radar sensors shall sense the presence of vehicles on the road and send the count to get aggregated. The total count will then be sent to the Data store that can be referred as and when required. Based on the total count of each lane, the density of vehicles is calculated.

The Need factor is calculated based on the density of vehicles, average speed of a lane and the time of the day and is used to determine the time slice required for a particular lane out of the total cycle time for the entire crossing.

These time slices are sent to the master microcontroller. The Master is responsible for synchronization of the signals. It sends the schedule to the respective slave and waits for the acknowledgement after the work has been completed.

After receiving the acknowledgement, it sends data to the next slave node. On completion of the entire cycle, the master node requests data for the next cycle and the process repeats.

In case the master does not receive any acknowledgement, implies that there is a synchronization failure. This may result in a threatening situation for the commuters. To tackle this situation, as soon as synchronization fails, the failure is reported to the authorities. The authorities can then analyze the system and rectify it to resume the normal working of the system. During the time that the system is being put right, the signals will be programmed to operate in a particular repetitive cycle so as to not cause any disturbance to the traffic flow.

### 3. IMPLEMENTATION

It is assumed that the system is an embedded and real-time in nature which is implemented using microcontrollers, network modules traffic lights and performs tasks like

1. Accepting real time traffic data from an input source, perform required calculations and then control the traffic lights in an adaptive nature.
2. Ensure synchronization between traffic lights.
3. Monitor and report failures of the system.

Assumption that a traffic density input will be provided by some other system to the proposed system is made and an interface will be provided to input the data value.

#### 3.1 System Architecture

The basic building block of the proposed system is defined as a node. As per architecture the node is a structure which consist of the Microcontroller, Controller Program, Communication module and Traffic light.

The control program will be installed on the microcontroller and the communication module will be interfaced with the microcontroller through a physical interfacing line. The traffic lights will be controlled by the microcontroller through a physical connection on its pins.

The nodes will be of type – Master node and slave node

The **Master Node** will run the master program in a thread and will be responsible for operations like

1. Data acquisition
2. Processing and Time slice calculation
3. Initiating communication and sending data to Slave nodes
4. Synchronization of nodes
5. Failure reporting.

The synchronization program will run on a different thread on the master node.

The **Slave Node** will run the slave program in a thread and will be responsible for operations like: -

1. Wait for the message of data from the master node
2. Control Traffic lights as per received data
3. Sending Synchronization reply to master

The synchronization program will run on a different thread on the Slave node

Figure 4 shows the architecture if the system

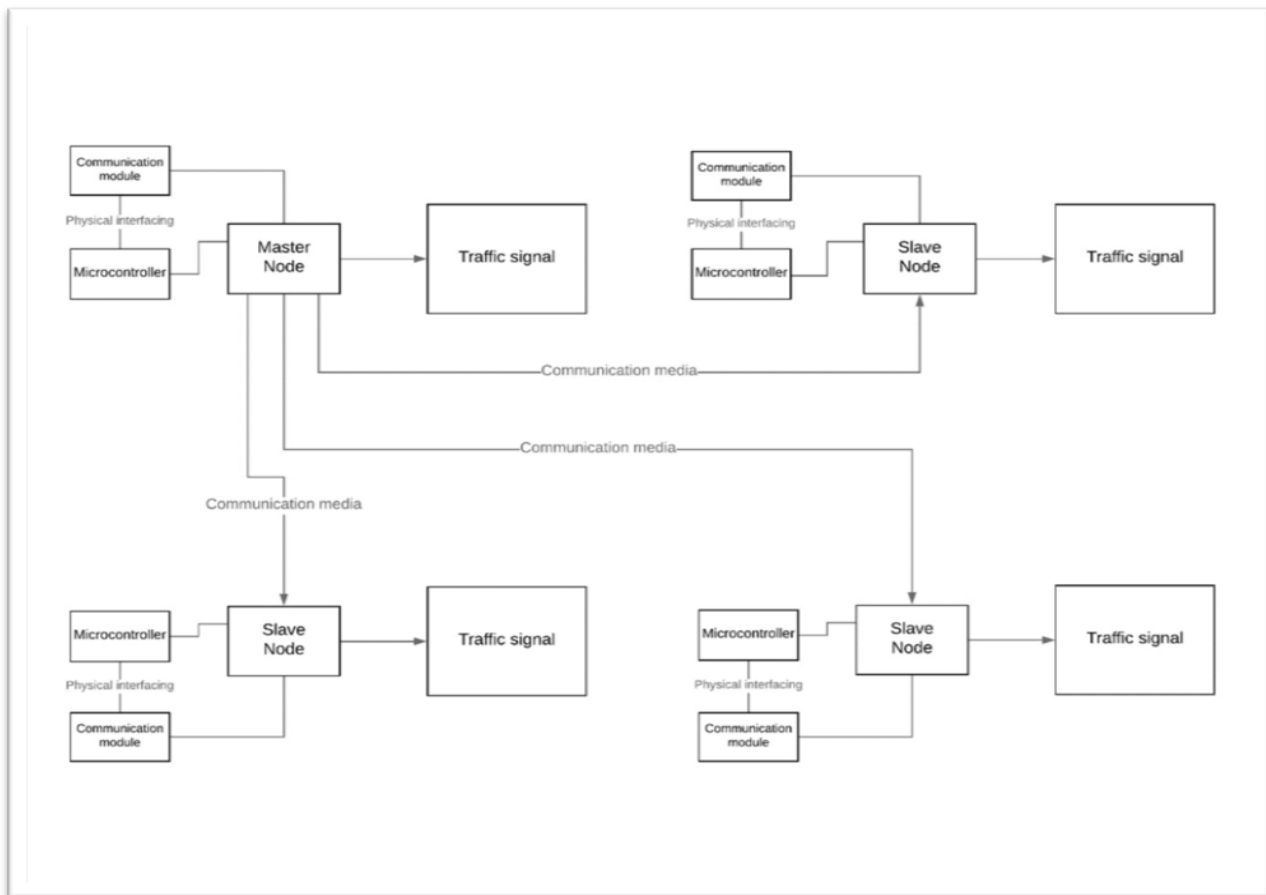

Figure 4. System Architecture

The inter node communication is supported hardware communication module and drivers/libraries to share information and also for synchronization messages. Traffic lights are controlled directly by a node’s microcontroller and lighting appropriate signal light is the responsibility of the slave node. One thing to note is that out of all the nodes at an intersection one of the nodes will run both master and the slave thread and rest will run only the client thread.

The system can be imagined as a collection of nodes interacting with each other to achieve the goal. Synchronization mechanism when uncovers any problem with the master then the responsibility of the master can be reassigned to another node as all the nodes are same from the hardware point of view, the only change is the software running on each of the node.

### 3.2 Implementation and Deployment

The proposed system is expected to function for a long-time span with minimal maintenance effort. However, it shall be implemented in an open environment of a city, which will endure from the effects of natural factors like harsh climate and will result in slow deterioration of hardware components. Hence the choice of hardware components has a very profound impact on the life of the system.

Moreover, cost is also an important factor to consider as the system is intended for mass installation around an urban area.

Hardware component like microcontrollers, communication module, driver modules are interfaced directly through microcontroller plug and play pins or using cables. Figure 5. Shows consideration of factors while choosing microcontrollers

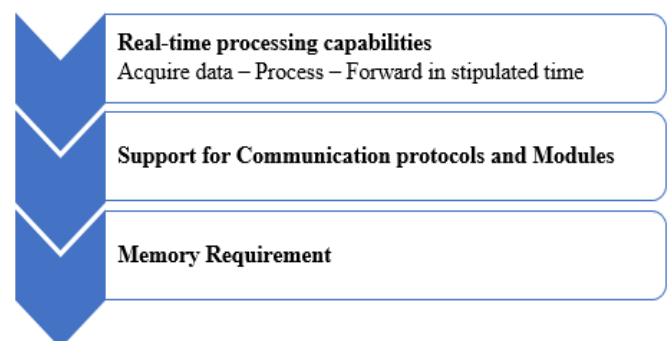

Figure 5. Factors for choosing Microcontroller

Vendor provided and readily installed operating system is used for easy operation of the controllers.

Vendor provided language compiler is used to develop and run embedded programs.

The communication modules refer to the hardware which supports various communication technologies and protocols that can be interfaced with a microcontroller to form a network and exchange information. The typical distance between two signals may vary but we can assume they may not exceed more than distance of 50 meters so any

communication module which can support at least 50 meters will be enough from the point of view of communication range.

Considering the range requirements of the system, wireless communication using radio frequencies shall be used. RF transceiver module along with its supporting libraries will form the communication interface.

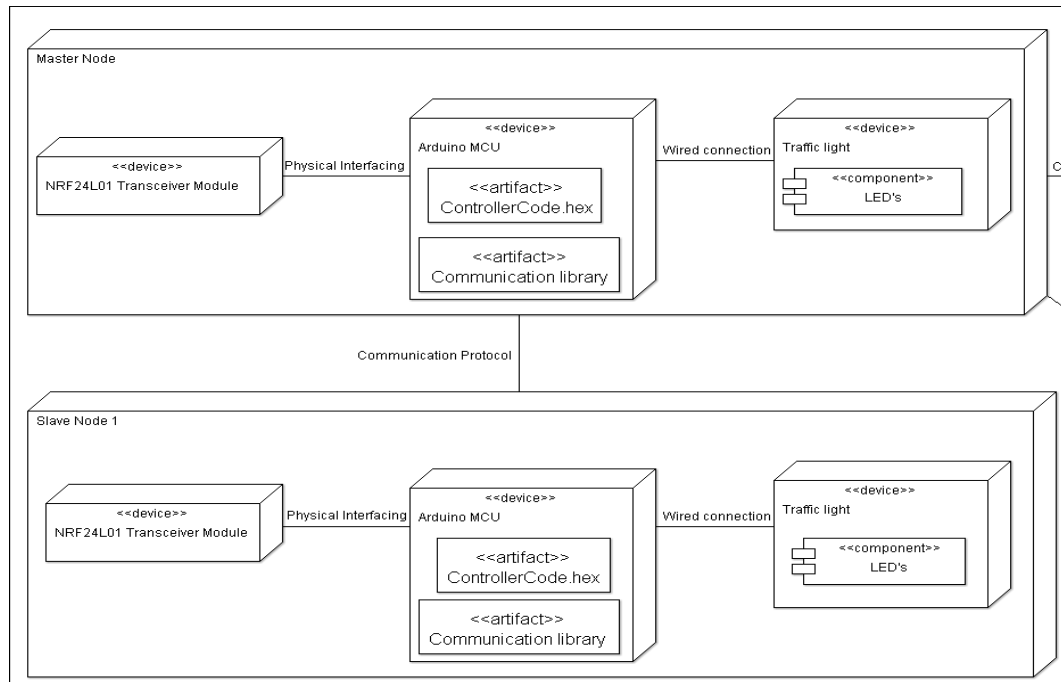

Figure 6. System Deployment Diagram

Choice of a stable power source is needed to maintain an uninterrupted supply of power to the traffic signal and the microcontroller. A backup battery along with an UPS shall be used to keep the system running in case of power discontinuation.

Figure 6. shows the system Deployment diagram showing the physical devices hardware and the communication between them.

### 3.3 Risk Management

Each traffic signal at a location will be embedded with a small IoT/Embedded system with computational and communication capabilities. Master slave architecture will be used for operation and co-ordination between all the traffic signals at a location. Out of which one signal will act as a master slave and rest others will act as a slave.

The main risk associated with traffic signal synchronization is failure of the hardware/software. It can be of the failure of master and/or slave node, a communication failure or total software failure.

The system shall use the heartbeat system to check the working of the system where the master will send a heartbeat signal to all the slaves at periodic intervals and the slaves must provide an acknowledgement to the master. Through the master, the working of the system analyzed and look for potential failure points.

If no acknowledgement received from the at least one slave, it means that either the slave has failed or there is a communication failure.

If none of the slaves return an acknowledgement, then mostly the communication between the master and slave has failed.

In case of loss of communication with the master, master failure or the total system failure is encountered.

The system shall be reset. To make the corrections, engineers or professionals that have knowledge about the system would have to correct the problem by going on the site the system has been installed.

#### 4. FUTURE SCOPE

The system shall receive data regarding the traffic density from an input source, perform required calculations and then control the traffic lights in an adaptive nature. The data received by the system can be stored locally and/or on cloud for further processing and analysis. Traffic engineering under the branch of civil engineering can use captured data for better planning and development to achieve efficient movement of people on roadways by proper processing and analysis.

This system can be extended to any intersection where it shall receive data regarding the traffic density from an input source, perform required calculations and then control the traffic lights in an adaptive nature

#### 5. CONCLUSION

An exponential increase in traffic congestions in urban areas has put immense pressure on existing road infrastructure and urban planning. With cities getting smarter and moving towards rapid development, using an adaptive based traffic signaling system that manipulates the traffic timing counter based on the distribution of traffic will provide some relief to the congestions thereby increasing safety on roads and reducing wastage of time and fuel. Roads can thus help pass a greater number of vehicles with minimum number of stops despite of limited space and resources available.

'Traffic Synchronization using Smart Signals' with the use of technology and innovation is thus an attempt to contribute towards the development and welfare of smart cities and nation for a bright future ahead.

#### REFERENCES

[1] Neetesh Kumar Jain, Atul Bhatore "Synchronization of Traffic Signal at Indore City (Radisson Square to Lavkush Square)" IJSRSET 2017

[2] Arash M Roshandeh, Li Zongzhi, Bei Zhou, "New Methodology for Intersection Signal Timing Optimization to Simultaneously Minimize Vehicle and Pedestrian Delays" 2014

[3] H.S Goliya, Nitin Kumar Jain "Synchronization of Traffic Signals -A Case Study – Eastern Ring Road, Indore" International Journal of Advance technology in Civil Engineering 2014

[4] Ilsoo Yun, "Stochastic Optimization Method for Coordinated Actuated Signal Systems" ASCE 2012

#### BIOGRAPHIES



**Gaurav A. Deshpande**  
Pursuing B.E in  
Information Technology  
MIT Pune



**Mayuresh N. Joshi**  
Pursuing B.E in  
Information Technology  
MIT Pune



**Archit Saraswat**  
Pursuing B.E in  
Information Technology  
MIT Pune



**Sumedha Sirsikar**  
Head, Department of IT  
MIT Pune