

# Industrial Gas and Fire Detection System

Gnana Sudha T<sup>1</sup>, Ankitha S<sup>2</sup>, Abhilash M<sup>3</sup>, Shreehari B V<sup>4</sup>, Vikas Reddy S<sup>5</sup>

<sup>1</sup>Student, Dept. of CSE, S J C Institute of Technology, Chickballapur, Karnataka, India

<sup>2</sup>Student, Dept. of CSE, S J C Institute of Technology, Chickballapur, Karnataka, India

<sup>3</sup>Student, Dept. of CSE, S J C Institute of Technology, Chickballapur, Karnataka, India

<sup>4</sup>Student, Dept. of CSE, S J C Institute of Technology, Chickballapur, Karnataka, India

<sup>5</sup>Assistant Professor, Dept. of CSE, S J C Institute of Technology, Chickballapur, Karnataka, India

\*\*\*

**Abstract** - The safety work environment is important for every worker in the industry, it is important to create a safer workplace. Fire and gas detection are vital issues for all areas of life where precautions are very important. In order to ensure safety, we are implementing a system based on the Internet of Things (IoT) that detects fire and gas leakage and sends an alert message to the floor manager and nearest fire station via a cloud application. Sensors are used to measure the gas emission, temperature, and humidity level and these can be recognized with the help of DHT11 and Flame detector used to detect the presence of fire. Sensor data is uploaded to the Cloud application using MQTT (Message Queuing Telemetry Transport) Protocol. Alerts can be triggered in case of drastic changes in Sensor values.

**Key Words:** Internet of Things (IoT), Sensors, NodeMCU, Ubidots, cloud.

## 1. INTRODUCTION

Internet of Things (IoT) is characterized as a framework containing computerized objects which are interconnected to one another, in this way giving human-to-machine or even some of the time machine-to-machine association without the mediation of human creatures for transmitting the information gathered over a system. Fire and gas discoveries are fundamental issues for all circles of lives where safeguards are significant. To guarantee security condition a framework has been created which is solid in recognizing fire and gas spillage and can even recognize the particular room or floor where the deficiency is available. In the proposed technique we use Node MCU as a control framework, gas sensors, fire sensor and temperature and humidity sensor. The yield of the data collected by the sensors is posted into Cloud applications using Internet of Things (IoT). In the area of IoT there has been numerous updates and development as per required by the individuals who utilizes it. IoT is simply one more approach to make regular daily existence simpler for people by creating brilliant gadgets. IoT gadgets have expanded 31% per and was at 8.4 billion in the year 2017. The absolute check is set to reach 30 billion gadgets continuously 2020. The market an incentive for IoT gadgets is additionally set to increment to \$7.1 million constantly 2020. IoT includes associating questions past the scope of standard gadgets which are utilized for ordinary purposes. The proposed paper targets

investigating the kind of industry, considering the idea of procedures included and distinguishing the chances of gas spillage and fire detection. Potential focuses can be distinguished and parallel sensors can be introduced which can screen and record the information. The large information can be send to Cloud application which encourages observing by approved faculty from any chunk of the globe. Starting preventive activities by cautions in the event of any variations found in the collected information can spare the valuable existences of many.

## 2. RELATED WORKS

### 2.1 IoT based Intelligent Industry Monitoring System:

In this paper, the authors identify the chance of gas leakage, fuel, and intent at examining the industry type along with considering the quality of processes. Here authors deployed few intelligent sensors to monitor pollution around us. In this world of Internet of things, it's very difficult to analyze the data where they integrated big data into the Google Cloud Platform through web servers. Here, the deployed prototype is with Raspberry Pi connecting different gas sensors like MQ-6, MQ7, MQ135, as well as temperature, and humidity also can be monitored by the DHT-11 sensor. The main idea behind this is to avoid accidents causing the existence of gas or fuel leakage in industrial areas. This can stop accidents by appropriate identification and alarming the surrounding people. This can also be used to detect the pollution level from vehicles and also be used to examine the smoke outlet from factories. This work also enables everyone to monitor the air quality in their place through mobile phones.

### 2.2 Internet of Things (IoT) Based Gas Leakage Monitoring and Alerting System with MQ-2 Sensor:

In this paper, the authors believe in the implementation of large-scale IoT devices that hopes to translate many prospects of the way people live. Here authors used the dedicated chip called ARM Cortex-M, a group of 32-bit RISC ARM processors along with LPG sensor MQ-2. MQ-2 is an ideal sensor that detects the existence of dangerous LPG leakage in service stations, vehicles, and homes. A prototype of a single-board computer Raspberry Pi with WLAN and Bluetooth has been used to monitor and control the detected gas level via sensor and interfaced with a freely developed web page. The author's work represented in this paper

specifies IoT technology to a further level. The principle working of gas leakage monitoring has been shown in this paper by running the Raspberry pi model efficiently along with the attached embedded system with necessary input and output gas levels.

**2.3 An IoT Based Low Cost Air pollution Monitoring System:**

In this paper, the authors developed a prototype for monitoring major air pollutant gas concentrations. The model uses low-cost nodes along with low-cost gas sensors with Wi-Fi. Co, CO2, SO2, and No2 can be measured using the sensor that gathers the data of several parameters and sent the same to Raspberry pi which acts as a base station. The proposed IoT Architecture here in this paper includes the presentation layer, network layer, and application layer. The presentation later deals directly with the field sensor network based on the front-end acquisition node. The network later deals with Data Transmission where authors used low-cost Node8266 to transfer the data wirelessly inside TCP packets from Raspberry Pi 3. The application layer includes both data storage and data visualization. Finally, they designed a very low-cost pollution monitoring system with a database server, web server, and wireless sensor network. By adding more sensing nodes, the whole project can be upgraded in terms of design and measurement results.

**2.4 Microcontroller based Low Cost Gas Leakage Detector with SMS Alert:**

In the industrial zones, environs, gas-driven vehicles (Compressed Natural Gas) such as buses, cars, etc. the leakage of gas becomes a major problem. To prevent this, there are many preventive methods, one of the best preventive methods is to install the gas leakage detection device, so the motto of the project is to develop a device that detects the leakage of the gas. The system or the device detects LPG gas using sensors, and also uses the Global System for Mobile Communication to send the message about the leakage of the gas via SMS to the registered mobile number. Liquefied Petroleum Gas (LPG) is by-product gas and also called Autogas in which it is a weightless, odorless gas with a mixture of propane, propylene, butane, and butylene in various mixtures. Hence the leakage of the gas can be easily detected because it's a natural state. The sensor that is used in this device is the MQ-5 sensor. LPG plays a very important role in our daily lives. But the main problem in developing such type of device is the security problem. Hence an ultimate action has to be taken.

**2.5 FPGA-GSM based Leakage Detection System:**

According to the author's perspective in this paper, explosion and severe damage to the environment is due to the failed attempt in the detection of gas leakage. The authors proposed a detection method of gas leakage in which the data is also sent to the immediate response team via wireless media. To interface between GSM and FPGA, a Universal Asynchronous Receiver/Transmitter (UART) has been used for sending and

receiving data. An 8 bit Analog to Digital Converter is also used to convert the sensor's analog data into digital. The data from the ADC is calculated and compared with a mentioned threshold in FPGA. If the gas is detected, the mobile number stored in the database is initiated to send the data to the GSM. Noise voltage is measured without gas to set the threshold value and normally the threshold is 0.02V. However, MQ6 is used for detection and it successfully detects a concentration of 220 ppm which is equal to a voltage of 0.61V. A gas leakage detector prototype has been built and tested successfully with LPG. This prototype is also able to send the alert calls to the mobile number stored in the database in a few seconds.

**2.6 Fire Alarm System Using IOT:**

Nowadays, life becomes more significant to the people who are working in industries and some small household industries also. The number of deaths is majorly caused due to the fire accidents so we have a smart fire detection system using IoT and this detection system empowered with the sensors, actuators, software, and other devices and in this, it mainly has a raspberry pi, Flame sensor, PIR sensor and gas sensor and these mainly connected through the internet which enabled the collection of the data from sensors and actuators and this collected data which may result in an indication of the fire and gas. Finally, this fire detection system is a well-organized solution for fire safety and still, it has some issues like modeling required to get a more model.

**3. METHODOLOGY**

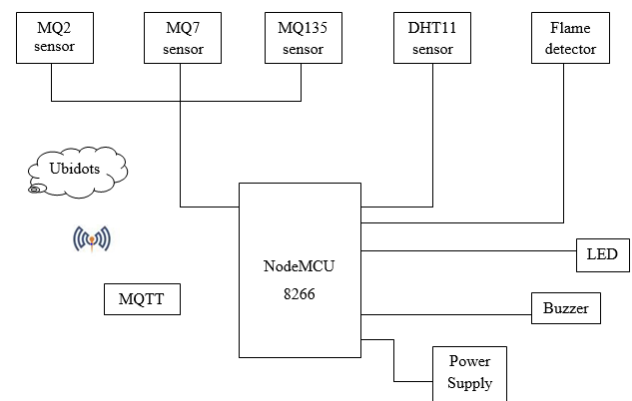

**Fig 1. Block Diagram**

In the above figure, the system will be completed to play out the recognition and examination of the information acquired whether to make a caution or not. In our project, we have made two areas: one is gathering rough data from the various sensors that appeared in the above figure in the equivalent arrangement and advising our system to circulate the rough data into the ubidots. In the ubidots, it will examine the information collected and it is conscious to make cautions and send alerts to the respected authorities. Information gathering relies upon MQTT protocol, MQTT represents Message Queuing Telemetry Transport. Where

this protocol is utilized to transmit the information to the cloud using a nearby remote network. MQTT is an open OASIS (Organization for the Advancement of Structured Information Standards) and ISO (International Organization for Standardization) standard lightweight, a publish-subscribe network protocol that transports messages between devices. The protocol generally runs over TCP/IP; regardless, any framework protocol that gives mentioned, lossless, bi-directional affiliations can support MQTT. Moreover, it's little size, low force utilization, constrained data packs, and simplicity of execution make the protocol perfect for the "Machine to Machine" or "Internet of Things" world. By then comes NodeMCU8266 where it controls and directs the information to circulate in the ubidots cloud. At the point when the information gathering is attested in the cloud, by then ubidots control the data to perform alerts and takes note.

#### 4. FUNCTIONAL MODULES

##### 4.1 MQ2 Sensor



MQ2 gas sensor is useful for gas spillage discovery (home and industry). It is suitable for distinguishing H<sub>2</sub>, CO, LPG, CH<sub>4</sub>, Alcohol, Smoke or Propane. As a result of its high affectability and quick reaction time, estimation can be taken as quickly as time permits. This sensor manages 5V DC voltage. It can recognize gases in the concentration of range 200 to 10000ppm.

##### 4.2 MQ7 Sensor



It is a Carbon Monoxide sensor reasonable for detecting CO fixations recognizable all around. It can recognize CO gas fixations somewhere in the range of 20 to 2000ppm. MQ7 is a high affectability to carbon monoxide.

##### 4.3 MQ135 Sensor



MQ135 is an Air Quality sensor used to recognize a wide extent of gases including alcohol, NH<sub>3</sub>, smoke, benzene, and CO<sub>2</sub>. The working voltage of this gas sensor is from 2.5V to 5.0V.

##### 4.4 DHT11 Sensor



DHT11 is a temperature and humidity sensor. It utilizes a capacitive moistness

sensor and a thermistor to quantify the encompassing air. The temperature extent of DHT11 is from 0 to 50 degrees Celsius with a 2-degree precision. The moisture extent of this sensor is from 20 to 80% with 5% precision.



##### 4.5 Flame Detector

A flame detector is a sensor that senses and responds to a flame presence. Flame and infrared light sources with wavelengths ranging from

760nm to 1100nm can be observed. This sensor's voltage is 3.3V to 5V.

##### 4.6 NodeMCU 8266

The NodeMCU (Node Microcontroller Unit) is an open-source software development environment based on a low-cost System-on-a-chip (SoC) called the ESP8266. It is an affordable Wi-Fi module that can be set up in the IoT network. In this project, NodeMCU provides safety solutions through alerting floor managers. The device will communicate with the existing Wi-Fi network.

#### 5. EXPERIMENTAL SETUP AND RESULTS



Fig 2. Hardware Setup

The device consists of gas sensor MQ2, MQ7, MQ135 for the detection of gas leakage, fire detector used to determine fire in the industry. Temperature, humidity can be measured using the DHT11 sensor and All sensors are connected to Nodemcu. Buzz is caused when the fire and gas emission exceeds the permissible limit.

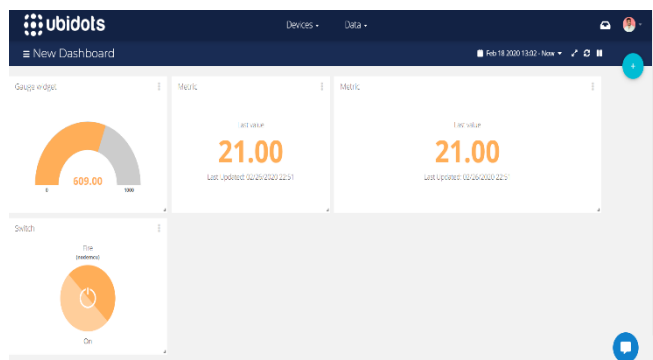

**Fig 3.**Ubidots DASHBOARD

In the above dashboard, gauge widget is used for the gas variable, metric widget for temperature and humidity variable which is measured in Fahrenheit and switch for fire variable.

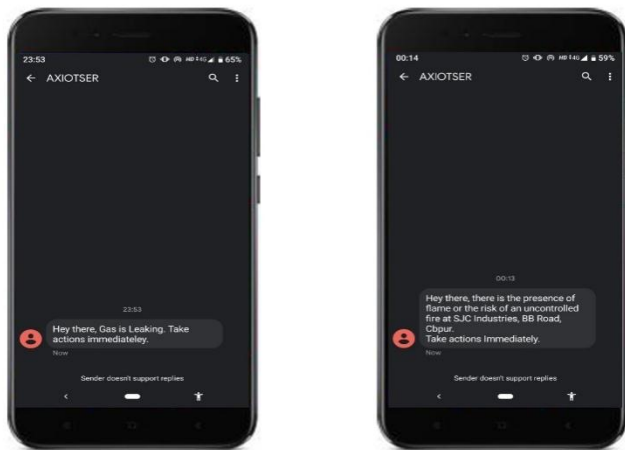

**Fig 4.** Notification Alerts

If the sensor's values increased above the allowable limit the alert message is sent to the floor manager and also to respective authorities about fire and gas leakage.

## 6. CONCLUSION AND FUTURE ENHANCEMENT

With the advancement of technology, the availability of the internet is supposed to be everywhere. We build an Industrial Gas and Fire Detection System using the Internet of things technology. In this paper, we have proposed a system that provides appropriate and efficient solutions for gas and fire detection. A NodeMCU 8266 prototype has been developed which can detect fire and gas concentration. Real-time data from various sensors have been uploaded to Ubidots. If the data obtained is found above the permissible limit, alerts are initiated. In addition to this, other parameters like temperature and humidity are also measured. The system can be further improved with automatic aeration fan when the gas leakage is detected and

self-activating water sprayers are used to avoid further fire expansion.

## REFERENCES

- [1] Kavitha.B.C, Vallikannu.R, "IoT based Intelligent Industry Monitoring System", 2019 on Signal Processing and Integrated Networks (SPIN) 6th International Conference.
- [2] Rohan Chandra Pandey, Manish Varma, Lumesh Kumar Sahu, "Internet of Things based Gas Leakage Monitoring and Alerting System with MQ-2 Sensor", IJEDR, Volume-5, Issue-2, ISSN: 23219939(Journal).
- [3] Gagan Parmar, Sagar Lakhani, Manju K. Chattopadhyay, "An IoT Based Low Cost Air Pollution Monitoring System", Proceeding International conference on Recent Innovations in Signal Processing and Embedded Systems (RISE-2017) 27-29 October, 2017
- [4] A. Banik, B. Aich and S. Ghosh, "Microcontroller based lowcost gas leakage detector with SMS alert", Emerging Trend in Electronic Devices and Computational Techniques(EDCT),Kolkata,2018.
- [5] Arpitha .T, Divya Kiran, V. S.N. Sitaram Gupta and Punithavathi Duraiswamy "FPGA-GSM based Gas Leakage Detection System", 2016 IEEE
- [6] R. Angeline, Adithya S, Abishek Narayanan, "Fire Alarm System Using IOT", International Journal of Innovative Technology and Exploring Engineering (IJITEE) ISSN: 2278-3075, Volume-8, Issue-6S3, April 2019
- [7] Ashish Srivasthava, Rathnesh Prabhakar, Rajeev Kumar, "GSM based Gas Leakage Detection System", International Journal of Technical Research and Applications, Volume-1, Issue-2.
- [8] Abdhulla al Noman, Rubel Kanti Das, "Detection of Fire and Gas Leakage in Industry to Ensure Safety Condition", 4th National Conference on Natural Science and Technology 2017.
- [9] Sagar Prem Lalwani, Mehakpreet Kaur Khurana Swati Jaikumar Khandare, Dr. Sanjay B. Pokle, "IoT based Industrial Parameters Monitoring and Alerting System using Arduino", International Journal of Engineering Science and Computing, April 2018.