

ENERGY HARVESTING USING PIEZOELECTRIC ARRAY

Dr. G. Ravi¹

¹Professor, Department of ECE, Sona college of Technology.

Saran R², Saran Ram K C³, Hariesh S P⁴, Harikrishnan R⁵

²⁻⁵UG Students, Department of ECE, Sona College of Technology.

Abstract: *Electricity is an important part of our daily lives and we generate energy using external sources such as windmills, solar panels and kinetic energy. Here we propose to generate electricity in ways that use roads and piezoelectric sensors. Piezoelectric sensors operate by converting mechanical energy (which is created by pressure) into electrical energy. Electricity is generated by pressure and vibration on piezoelectric sensors placed on roads. When the vehicle is moving, the sensor generates electrical energy by sensing the pressure of the vehicle's load. It is then stored and used for signals, streetlights, etc.*

Keywords: Piezoelectric sensor, Electrical energy, Pressure, Vibration

Introduction

Energy is nothing but the ability to work. In everyday life, electricity is the most used energy source. Now the demand for energy is growing and it is the livelihood of the people. Because of this, energy sources are generated and wasted. To generate electricity from these sources, electricity can be generated from sources such as water and air, requiring high operating costs for large plant development. Other fuel sources are also expensive and can cause pollution. They are not affordable to the general public. Electricity has become an important source of energy for humans, so waste energy needs to be used. Walking is the most common activity humans do, but energy is wasted as vibrations for the surface. And this waste energy can be turned into electricity using the principle of piezoelectric effect. The piezoelectric effect is the effect of mechanical vibration. The pressure applied to the piezoelectric material is converted into electrical form. This paper gives you ideas on how to use energy when stepping on the stairs. The use of stairs in each building is increasing day by day, even in smaller buildings, we can use this waste energy and can be converted into electricity by piezoelectric effect. The piezoelectric effect is the effect of specific materials to produce an electric charge in response to applied mechanical stress.

Literature review

Osman Ulkir¹, Ishak Ertugrul², Ayhan Alveroglu³. In recent years, due to technological advances, industrial reform and a growing population to supply rising energy demand; Micro-level systems have been improved. These systems are suitable for obtaining electrical power at the micro level. With the help of kinetic energy in electrical devices, the use of piezoelectric materials can produce electrical energy. In this study, a variety of piezoelectric materials and springs were used to generate electricity in the hand holders of a public transport vehicle. Electricity is generated as a result of the force on the surface of the piezoelectric material according to the applied force. An energy calibration circuit is used to transmit the received power to supply the optimum voltage and reduce the load loss. Many experiments have been carried out by applying the load to a different value in the production of piezoelectric materials.

Santosh Mugali¹, Bindu G², Subbalakshmi Chilukuri³, Deepthi G⁴, Kavya B⁵. A sophisticated step-down power generation system proposed here uses piezoelectric sensors to generate energy through the Pozzo, which we achieve by applying a fixed alignment such as stepping on piezo plates. This project describes the use of piezoelectric materials to derive energy from vibrating mass for energy generation and accumulation. The basic working principle of the "fossil power generation system" is based on piezoelectric sensors. When the floor is engineered with piezoelectric technology, the electrical energy generated by the pressure is captured by the floor sensor and converted into an electrical charge by the piezo-electric transducer. These sensors are positioned to produce maximum output voltage. This output is provided to our monitoring circuitry, a microcontroller based circuit that allows the user to monitor the voltage and charge the battery, and this power source has many applications. Our project model is cost effective and easy to implement.

Madhu P¹, Dr. S Pradeep², Mallappa D³, Manjunath H⁴, Ningappa N⁵, Prashant M⁶. Now it is necessary to generate electricity in those days, where wasted energy can be used to generate electricity. Piezoelectric effect is a method of converting mechanical energy into electrical energy. The aim of the present work is the smart use of physical properties and open procurement conditions for

the cultivation of human energy and the efficient production of electricity, which provides not only efficient energy sources but also a clean and pollution free environment. Does. Current work includes the use of power generation tile (EGT), which is cheap and easy to install. Because it is small in construction, it can be installed anywhere and uses a completely harmless formula. In the present work, a theoretical model on the generation of electricity by piezoelectric materials connected to flexible construction is developed and experimentally tested. The proposed work has been successfully tested and implemented as an affordable, affordable energy solution for the general public. This method can be used for many applications that have little or no power availability in rural areas.

Aganit Thakur¹, Manisha Dewangan, Priya Lalwani³.

The project aims to generate electricity and reduce fossil fuel consumption and conserve electricity for further use. In the modern world, technology needs power for its various functions. These fossils require much fossil fuel to offset electricity and fuel consumption. In this paper, we present a method for generating pollution-free electricity through technology, i.e. piezoelectric effect. This is a green solution for electricity generation. The piezoelectric effect is the ability to generate electrical charge by applying mechanical stress. This report evaluates the commercial status of piezoelectric based technology in road and railways. In this project we will try to provide enough energy because it will lose the pollution caused by power plants. Even when vehicles cross the road, they can hit the roads and cause disability. So to use a vehicle growing on the road, we can generate electricity through our project and help the environment and our structures stay longer. This paper is about piezoelectric sensors applied under the road bed to collect electricity from vibrations generated by moving a vehicle on the road. The main principle behind this project is the piezoelectric effect. Energy is generated through consumer participation and does not require a separate source of input power.

Existing system

There is a grid-connected photovoltaic power system with high voltage gain. For a typical PV array, the output voltage is too low and a high voltage gain is necessary to realize the grid-connected function. The proposed PV system uses a ZVT-interleaved boost converter with winding-coupled indicators and active-clamp circuits as the first power-processing step, which can increase the low voltage of the PV array to high DC-bus voltage. Two compensating units are added for display in the system control loop to achieve a fast dynamic response of output current and low total harmonic distortion. Furthermore, to reduce the cost of system complexity and high performance, a simple

maximum power-point-tracking method based on power balance in PV systems is applied.

Proposed system

The goal of this proposal is to extract energy from the roads through piezoelectric sensors / crystals using the Internet of Things, which helps to save energy by using stored energy instead of the normal power supply. Piezoelectric sensor arrays are placed on the roads at various locations. As shown in the design of the system, the entire array is combined into a compressor that produces electrical energy from mechanical energy and the generated electrical energy is converted from an alternator into a direct current. The generated current is stored in a battery for further use. The microcontroller controls the system and street lights, signals, etc. All processes are handled with the help of the Display Unit.

Block diagram

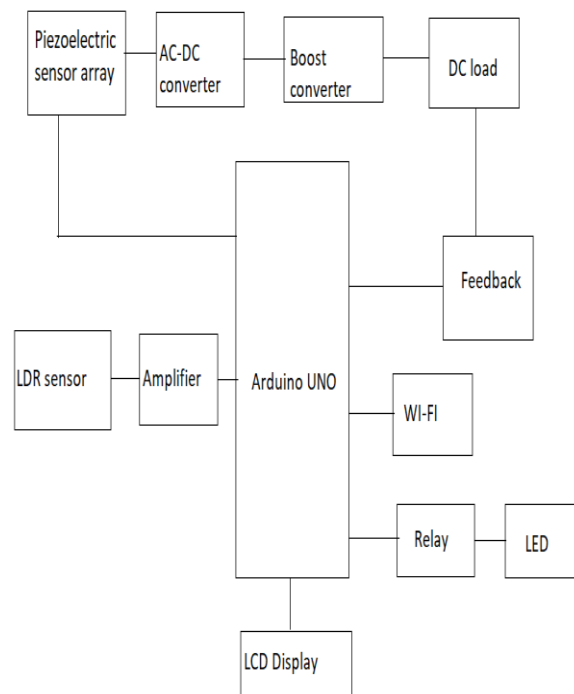

FIGURE 1. Block Diagram of Proposed System

Piezoelectric sensor

Piezoelectric sensor is a device that measures the pressure, acceleration, tension or force used by the piezoelectric effect by changing the electrical signals. The piezoelectric disk produces voltage when distorted (shape change is very exaggerated).

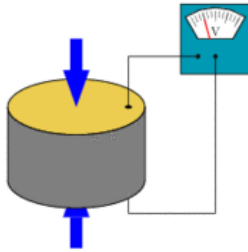

FIGURE 2. Piezoelectric sensor

IOT (Internet of Things)

The Internet of Things (IoT) is a network of physical devices, appliances, vehicles and electronics, software, actuators, sensors and other objects embedded in connectivity that enable users to connect, collect and exchange data.

LCD Display

Liquid Crystal Display (LCD) is a thin, flat electronic visual display that uses light modulating properties of liquid crystals (LCs). LCs do not emit light directly. They are used in many applications, such as computer monitors, instrument panels, televisions, signage, and aircraft cockpit displays. They are common in consumer devices such as gaming devices, video players, watches, telephones and calculators. LCDs have demonstrated cathode ray tubes (CRTs) in many applications.

Arduino UNO

The Arduino Uno is a microcontroller board based on the ATmega328P. It has 6 analog inputs, 14 digital input / output pins (6 of which can be used as PWM outputs), 16 MHz quartz crystal, power jack, ICSP header and reset button, USB connection. It includes everything needed to support microcontrollers. Connect it to a computer with a USB cable, or power it with an AC-to-DC adapter or battery to start it up. You can tamper with your UNO without worrying too much about doing anything wrong, the worst case scenario is that you can turn this chip into a few dollars and start again.

WI-FI

A Wi-Fi-enabled device, such as a video game console, a personal computer, Smartphone or digital audio player, can connect to the Internet when within range of a wireless network connected to Internet.

Result

The system helps to store energy by utilizing pedestrian pressure running along the route and efficiently using stored energy for street lights and other electrical energy use. Thereby conserving energy that is traditionally transferred to street lights and others.

Conclusion

In this efficient way we generate electricity using piezoelectric plates. The main feature of this project is generating energy from everyday movements such as vehicle movement and human movement. Generation power technology is growing day by day. Our project is a new innovative method of generating electricity and reused by many other applications. The use of piezoelectric crystals was introduced and positive results were obtained. Further advances in electronics, the selection and installation of better synthesized piezoelectric crystals, can generate more electricity and be seen as the next promising source of electricity. Non-conventional, non-polluting energy can be reduced, which maintains the general economic standards. The need for electricity is growing day by day. Nowadays everything depends on electricity. So this is the main reason for designing this project.

References

- 1) Prabaharan R, Jayramaprakash A, Vijay Anand. "Power Harvesting by Using Human Foot Step"- International Journal of Innovative Research in Science Engineering and Technology, vol.2, issue 7, July 2013.
- 2) Ramesh Raja R, Sherin Mathew. "Power Generation from Staircase (steps)"- International Journal of Innovative Research in Science Engineering and Technology, vol.3, Issue 1, February 2014.
- 3) Itika Tandon, Alok Kumar."A Unique Step towards Generation of Electricity via New Methodology"- International Journal of Advanced Research in Computer and Communication Engineering, vol.3, Issue 10, October 2014.
- 4) Kiran Boby, Aleena Paul K, Anumol. C.V, Josnie Ann Thomas, Nimisha K.K."Footstep Power Generation Using Piezoelectric Transducer"- International Journal of Engineering and Innovative Technology, vol.3, Issue 10, April 2014.
- 5) Jose Ananth Vino, AP."Power Generation Using Footstep"- International Journal of Engineering Trends and Technology, vol.1, Issue 2, May 2011.
- 6) Alla Chandra Sekhar, B Maruti Kishore, T Jogi Raju."Electromagnetic Foot Step Power Generation"- International Journal of Scientific and Research Publication, vol.4, Issue 6, June 2014.
- 7) Shiraj Afzal, Farrukh Hafeez."Power Generation Footstep"- International Journal of Advancement in Research and Technology, vol.3, Issue 4, April 2014.

- 8) K. Ramakrishna, Guruswamy Ravana, Venu Madhav Gopaka."Generation of electrical Power through Footsteps"- International Journal of Multidisciplinary and Current Research.
- 9) Umeda, M., Nakamura, K., and Ueha, S. Energy Storage Characteristics of a Piezogenerator Using Impact Vibration. Japan Journal of Applied.