

TIME HISTORY ANALYSIS OF CIRCULAR AND SQUARE SILOS

Nikhil G. Magare

PG Student Department of Civil Engineering, MGM JNEC Aurangabad, Maharashtra, India

Abstract - The elevated cylindrical storage silos are lifeline structures and strategically very important, since they have vital use in the industries. Silos are special structures subjected to many different unconventional loading conditions, which result in usual failure modes. In addition silos are cantilever structures with the material stacked up very high vertically. The earthquake response of silo structures for the storage of bulk solids differs for elevated silos and silos supported directly on ground. In the present study we performed time history analysis using STAAD-Pro V8i for circular and square R.C.C silos, by applying Bhuj ground motion data and studied the dynamic results like time -Acceleration, time-displacement, time-velocity and different mode shapes.

Key Words: Time history analysis, square silo, circular silo, Time-velocity, Time Acceleration, Time displacement, Mode shapes

1. INTRODUCTION

Storage structure like bins are basically called as silos and bunkers for storing different type of materials. Plane of rupture is important part to classified silo and bunker structure. If plane of rupture is intersect the opposite site of structure then it is called as silos and if plane of rupture is intersect the top of the surface of the structure then it is called as bunker. As per IS: 4995 (Part-I): 1974, to achieve a reduction in lateral pressure over large height, it may be preferable to select a height/diameter ratio greater than or equal to two. Silos are constructed in various shape such as circular, square, rectangular and polygonal shape with provided roof and bottom which may be pyramidal, conical or flat. The support system of silo is with the number of column, total structure wall, hopper bottom and column is connected with ring beam and plinth beam to distribute load. Vertical and horizontal both pressure need to consideration for design of silo structure.

Due to the many factor acts during the emptying and filling material process it is difficult to calculate exact pressure. To assure life safety and to maintain it essential functions, during structural design of silo various load applied according to its intended use, sizes, structure type, materials, design life-time, location environment. Due to the larger mass concentrated above the slender portion seismic load is as basic requirement in structure design.

1.1 Calculation of Bin Load:-

There are two methods suggested by IS-4995(Part I):1974 is Janssen's Theory and other one is Airy's Theory to calculate bin loads.

Janssen's Theory: The assumption that portion of the weight of the contained material is supported by friction between material and the wall, and only a small portion of weight is transferred to the hopper bottom. Due to this, Rankine's (1857) or Coulomb's (1776) lateral pressure theories cannot be directly applied. The vertical walls of the silo are subjected to direct compression as well as lateral pressure.

Airy's Theory: Airy's analysis is based on Coulomb's wedge theory of earth pressure. By this theory, it is possible to calculate the horizontal pressure per unit length of the periphery and the position of the plane of rupture.

2. METHODOLOGY

The aim of this time history analysis is to check the behavior of circular and square R.C.C silo with the STAAD-Pro for Bhuj earthquake data.

2.1 Data considered

Type of Silo = circular and square

Type of material stored = Wheat

Bulk density of material stored = 7.85 KN/m³

Height of silo = 16 m

Height of conical hopper = 2.25 m

Column size = 400 mm X 400 mm

Hoper opening = 0.5 m dia. For circular &

Hoper opening = 0.5 m b=d For square silo

Height of column above plinth = 6 m

3. Modelling and analysis

The modelling and analysis done in STAAD-Pro V8i software with the dimension taken under consideration. The model consist of 4 columns and fixed supports, beams , plates and nodes as shown in fig.1 and fig 2 which shows the top view and 3D view of circular and square silo in STAAD-Pro V8i .

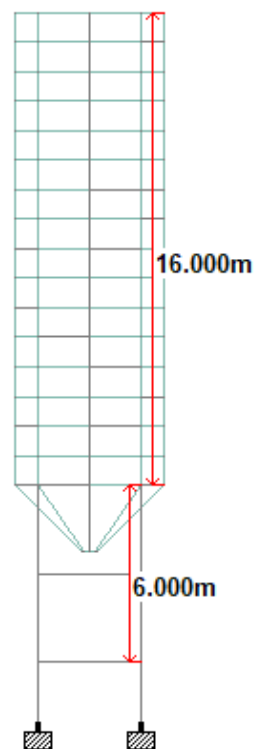
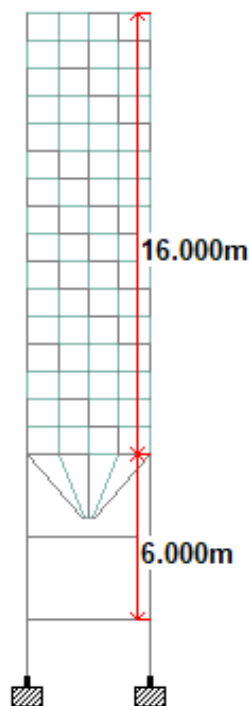
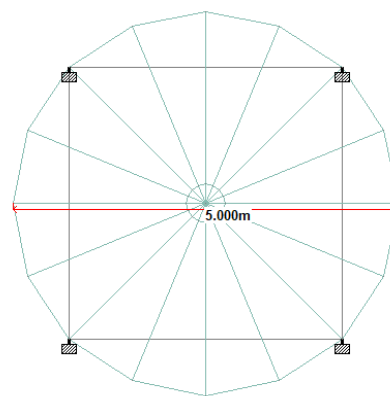
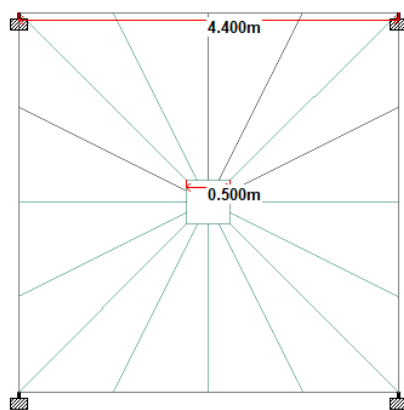

Fig.1 plan and elevation of square silo

Fig.2 plan and elevation of circular silo

4. RESULT AND DISCUSSION

4.1 Time History Analysis

It is an analysis of the dynamic response of the structure at each increment of time, when it's base is subjected to a specific ground motion history. This means the method requires site specific ground motion studies. However in majority of cases the time history method is not warranted.

4.2 Mode Shapes

Mode shapes are the displacement shapes of a vibrating system corresponding to the natural frequencies.

Under the undamped free vibration of MDOF building having N degrees of freedom, the building will vibrate in N modes of vibration.

Following are some of mode shapes observed after analyzing the circular and square silos.

4.2.a Mode Shape - 1

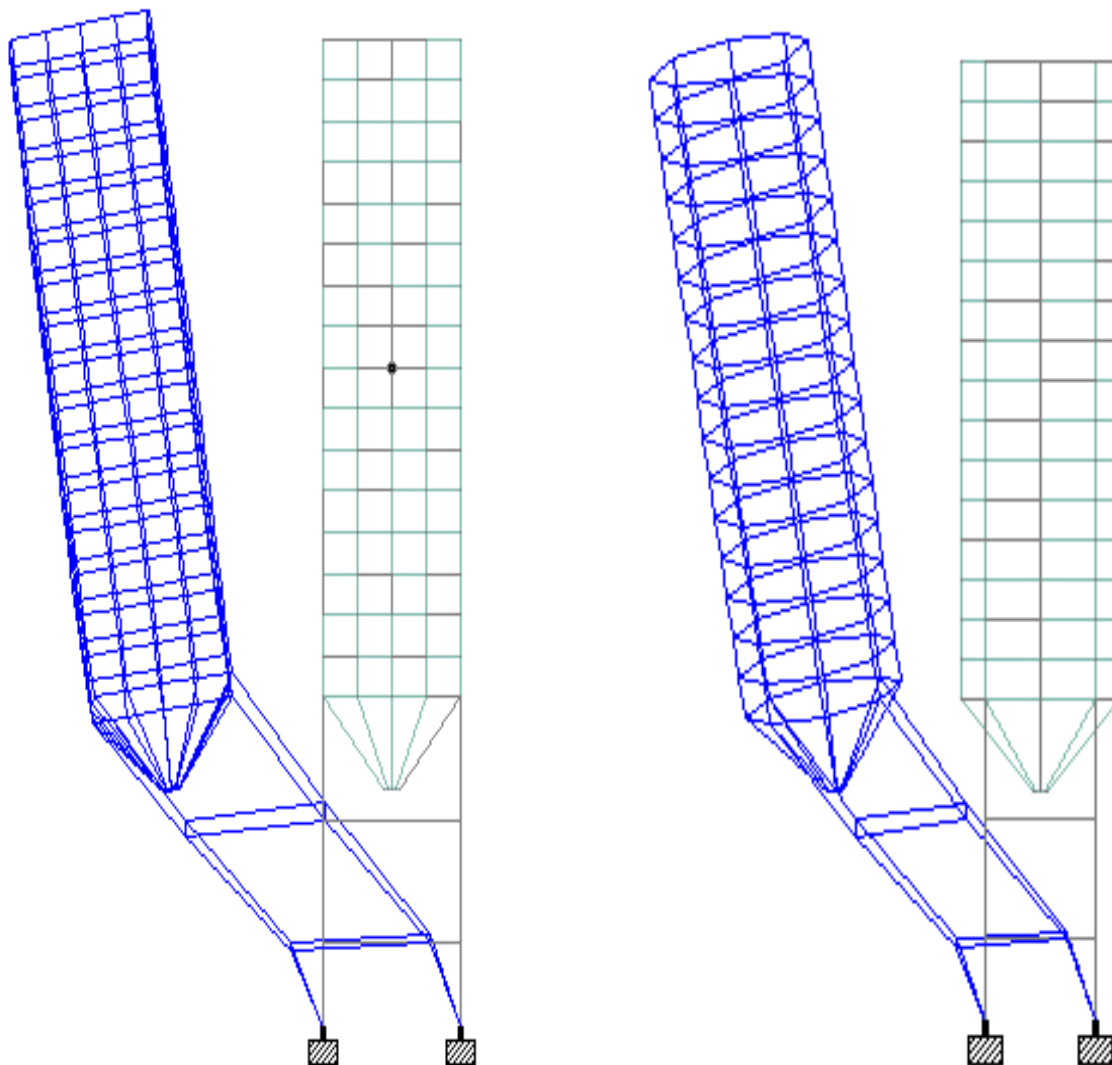

4.2.b Mode Shape - 2 : same shape in opposite direction

4.2.c Mode Shape - 3

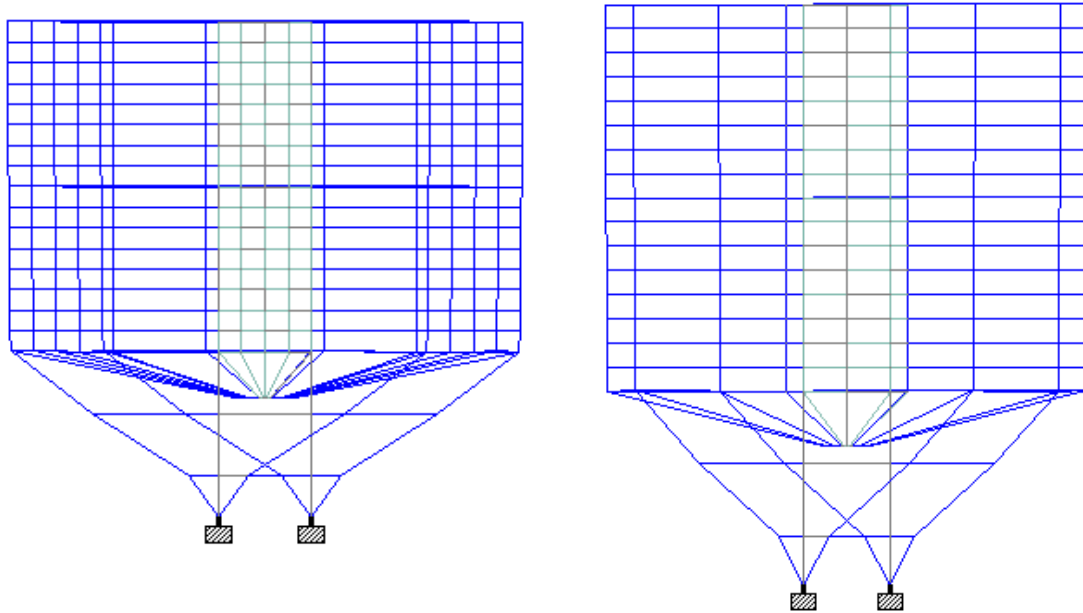

4.2.d Mode Shape - 4,5

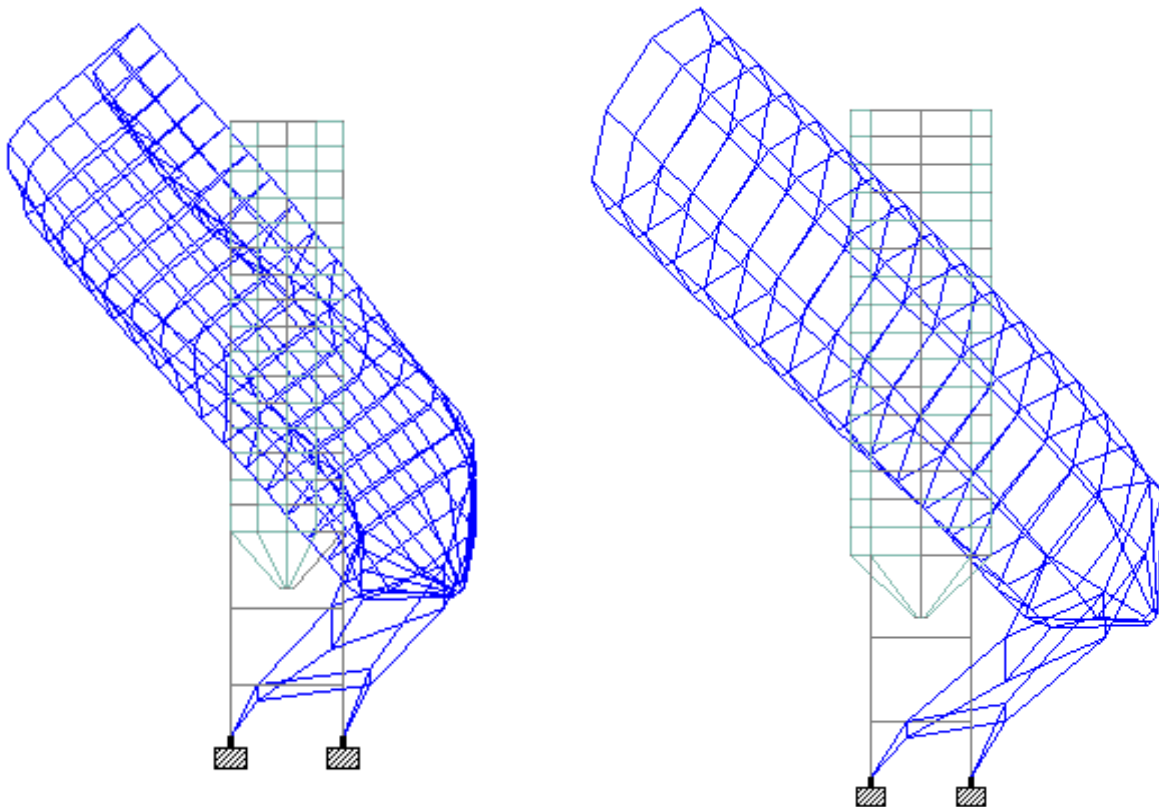

4.2.e Mode Shape - 6

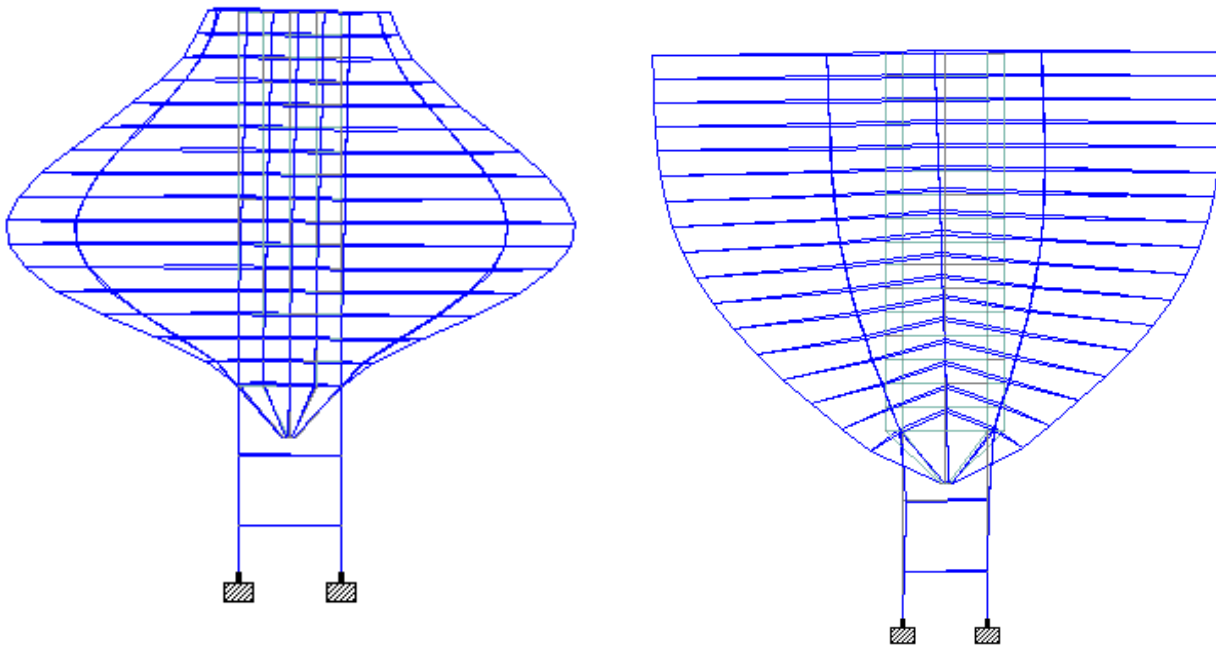

Above fig shows 6 different mode shapes of silos. Square silos are on LHS and circular silos shape are on RHS.

Table -1: Mode shape of square and circular silo

Mode NO	Square silo		Circular silo	
	Frequency (Hz)	Period (s)	Frequency (Hz)	Period (s)
1	0.792	1.262	0.722	1.386
2	0.792	1.262	0.722	1.386
3	1.434	0.697	1.158	0.863
4	3.670	0.273	3.345	0.299
5	3.672	0.272	3.345	0.299
6	4.072	0.246	4.718	0.212

Above table is giving information regarding the six mode shapes, we created with STAAD-Pro V8i. The frequencies and period for different mode shape is tabulated in above table. This results shows that the frequencies and period values are higher towards square silos.

4.3 Time-Acceleration

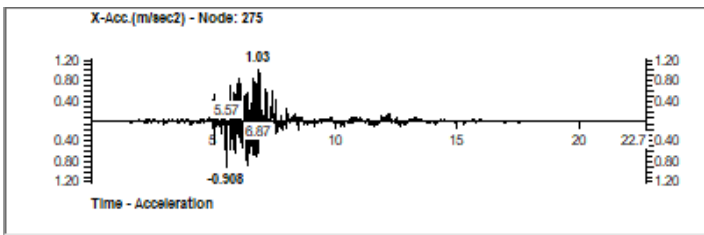

X- Acceleration of Square silo

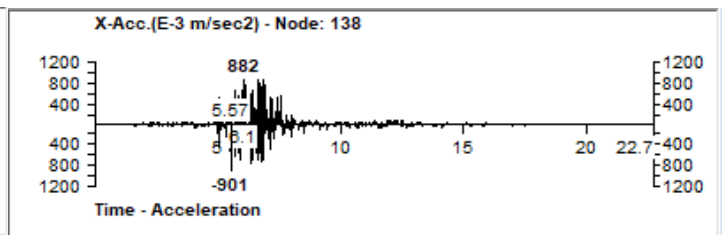

X- Acceleration of circular silo

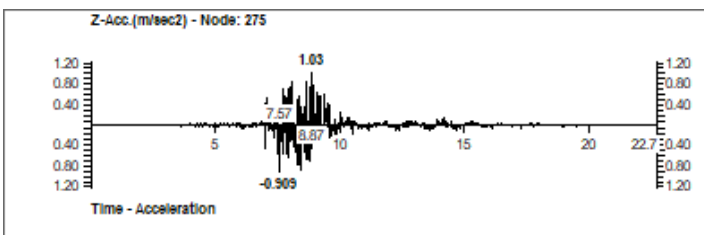

Z- Acceleration of Square silo

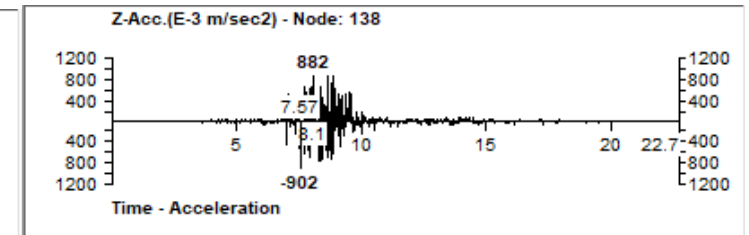

Z- Acceleration of circular silo

4.4 Time-Velocity

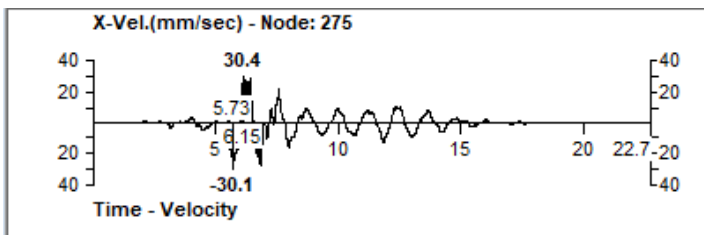

X- Velocity of Square silo

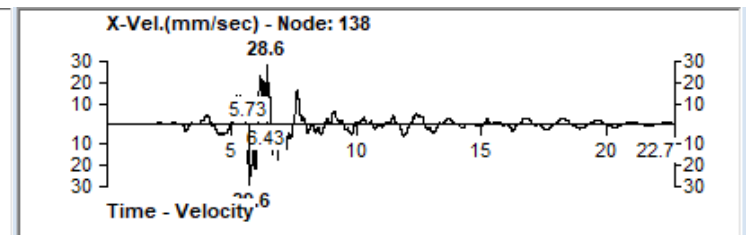

X- Velocity of circular silo

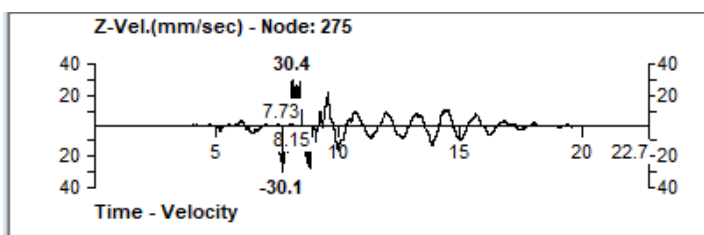

Z- Velocity of Square silo

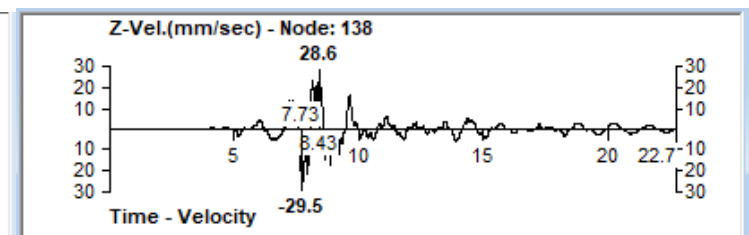

Z- Velocity of circular silo

4.5 Time-Displacement

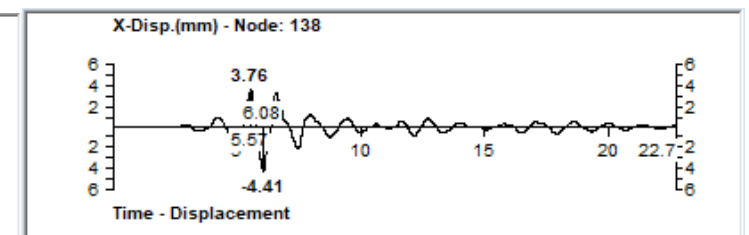
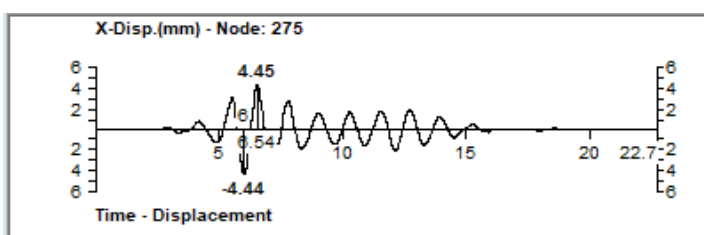

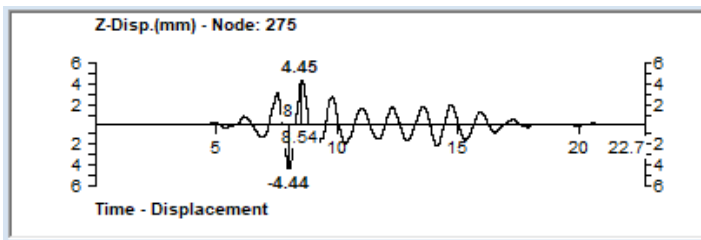

Z- Displacement of Square silo

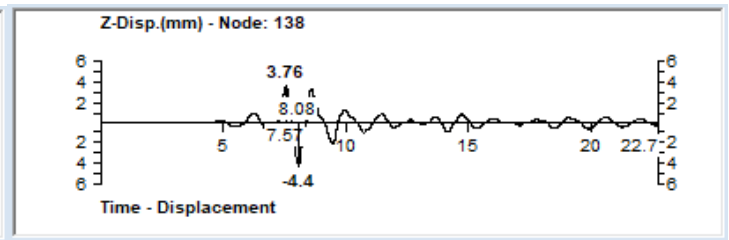

Z- Displacement of circular silo

5. CONCLUSIONS

1. The frequencies and Period for different mode shapes compared it shows higher values towards square silo.
2. The time-acceleration values along X-direction and Z-direction are more in square shaped silos.
3. The time-velocity values along X-direction and Z-direction are more in square shaped silos.
4. The time-displacement values along X-direction and Z-direction are more in square shaped silos.
5. Overall from above conclusion it can be concluded that the circular shape performs better than square shape silos.

REFERENCES

- [1] M.D. Sharique Beg¹, Ashish Yadav², "SEISMIC ANALYSIS OF ELEVATED STEEL SILOS UNDER DIFFERENT FILLING CONDITIONS", ijates vol. No.5,issue No.4 , April 2017
- [2] Ashwini Bidari¹, K.N.Vishwanath², "Analysis of Seismic and Wind Effect on Steel Silo Supporting Structures", International Journal of Research in Advent Technology, Vol.2, No.9, September 2014 E-ISSN: 2321-9637
- [3] Reshma Roy¹, Divya P Paul², "Comparison of Base Isolation Techniques for Reducing Seismic Vulnerability of Elevated Steel Silos", IJISET - International Journal of Innovative Science, Engineering & Technology, Vol. 5 Issue 4, April 2018
- [4] Varun.G¹, Kavan M.², "Study of Behaviour of RC Silo for Lateral Loads Using Sap", International Journal for Research in Applied Science & Engineering Technology (IJRASET) Volume 5 Issue IX, September 2017
- [5] Hamdy H.A. Abdel-Rahim¹, "Response the Cylindrical Elevated Wheat Storage Silos to Seismic Loading", IOSR Journal of Engineering (IOSRJEN) Vol. 04, Issue 01 January. 2014
- [6] Raj Kumar Janghel¹, R. C. Singh², "Dynamic Analysis of Cylindrical Steel Silo Structure with the Effect of Shear Wall", IJARIE-ISSN(O)-2395-4396 Vol-4 Issue-5 2018
- [7] Chirag L. Korat¹, Jasmin A. Gadhiya², Hardik A. Patel³, "A Review on Parametric Study of Circular RCC Silo having Hopper Bottom", Scientific Journal of Impact Factor (SJIF): 4.72 Volume 4, Issue 11, November -2017