

A Real Time Crime Intelligence System using Data Mining

Kavya R¹, Dr. Natesh M², Vinay M G³

¹Student, Dept of computer Science and Engineering, Vidyavardhaka College of Engineering Mysore, Karnataka, India

²Associate Professor, Dept of computer Science and Engineering, Vidyavardhaka College of Engineering Mysore, Karnataka, India

³Assistant Professor, Dept of computer Science and Engineering, Vidyavardhaka College of Engineering Mysore, Karnataka, India

Abstract - Real time crime intelligence system is where detecting the crime pattern and its frequency in the respective localities the respective paper concentrate particularly about the crime even which happen in very small localities, by developing a system application for the investigating agencies by using the concepts of data mining with the help of comparative analysis of two algorithms i.e. Apriori and apriori tid with the association rule combined. Which lead to the decrease in the crime rate because precaution is better than cure.

Key Words: Real time application, comparative analysis, apriori algorithm, apriori tid algorithm, association rule, small localities.

1. INTRODUCTION

Every nation suffer from a tremendous rapid crime rate which is increasing day to day which lead to the insecurity felling to every individuals leading their lives in every nation and countries. Many investigation agencies are trying technological improvisation in their investigation to solve the problem in the aspect of crime.

The paper represents the project developed by an author in the form of system application in the field of crime. The application is a real time application where it can be installed and run and make usage of it with any system environment.

The new approach in the application developed is, there is an comparative analysis of two algorithm which were used to develop an system application i.e. apriori and apriori where the two algorithms which were used with the same datasets to demonstrate apriori tid algorithm is more better than apriori algorithm with respect to the timeliness. Where the time taken for the data processing by the apriori tid is less when compared to the apriori algorithm. Where both the algorithm works similarly but differ only in

few algorithmic steps. Association rule comes into picture in both the cases of algorithms.

We are using a little old but very widely used waterfall model here where http works as data protocol. In early crime applications the frequency of the crime in small localities where not given importance where as in this paper it tells us that here crimes at small localities where given importance with the mitigation of crime rate with the help of the application developed with new technologies like the proposed algorithm. Results in crime detection at an early stage by informing about the crime prediction to every local crime stations or to any local investigation agencies

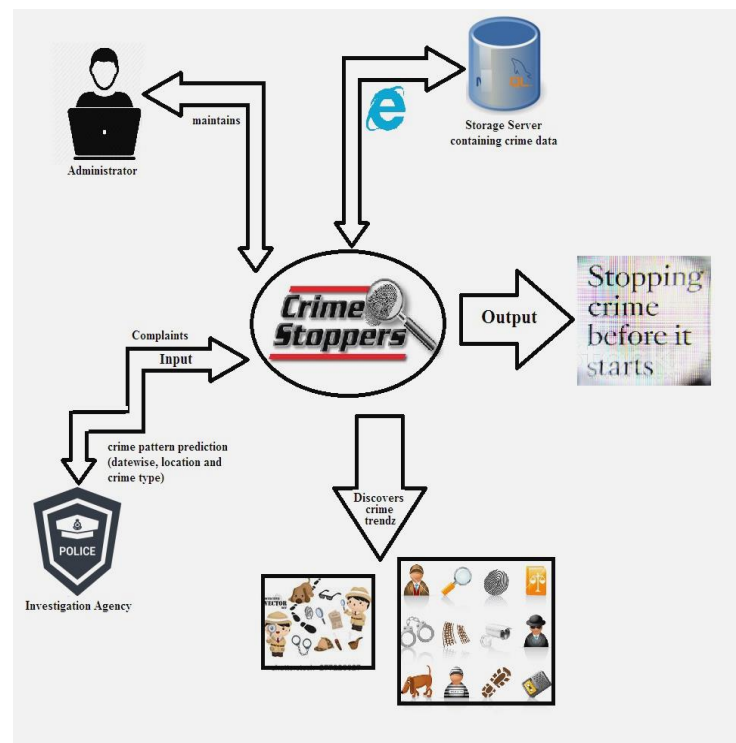

Fig1: Architecture of the project.

2 .LITERATURE SURVEY

In this paper the author has explained about mainly the data accessing method where it is accessed through only when perfect crime recorded time provided otherwise the respective IA's cannot access the crime details about the respective crimes[1]. Here they have deployed the Navies algorithm with the Mongo db as the database storage in the machine learning as the main project development domain.

In this paper the datasets are mainly held by the clustering analysis method with the support of k-means algorithm. Clustering method is deployed under the guidance of some data mining techniques. Here the data at the basic level will be examined in a detail manner [2].

In this paper the details about the crime must be fed to the system properly if any one among this two fails the application will not work accurately because the application in this paper will extract the crime details only on the basis of the exact time and place provided by the police department or any IAs. Visualization of the results is given more importance here where the crime details or output of the crime are clearly depicted to the public and police department clearly by the application by using some visual effects like color representation according to the crime rate inside a particular nation. As usually here also data mining and apriori algorithm concepts are used [3].

3. REQUIREMENT ANALYSIS

To achieve the aim of this system, the system requirements need to be determined. In this part the detail of the requirements will be determined in the following steps:

System Requirements

Functional Requirements: these requirements are ways used to determine the functions of the system or the components of these functions. It could be processing data, calculations, organizing instructions or other things needed to be done by the system regarding user requirements.

Few functional requirements of the project described in the paper are depicted below:

- The system consists of mainly 3 actors in it as: Admin, Public, IA.
- Admin only one who registers IA.

- System proposed which is depicted in the paper works on the basis of previous crime databases.

The system requirements of this project are

Software requirement:

- Frame work: DOTNET
- IDE: Visual Studio 2010
- Front end: ASP.NET 4.0
- Programming Language: C#.NET
- Back End – MS SQL Server

Hardware Requirements

- RAM: 1GB+
- Processor: Pentium 4+
- Processor Speed: 2 ghz+
- Hard Disk: 20GB+

4. DESIGN

The two major components of system development are system analysis and system design. The system architecture is established in system design phase. It maps the requirement into architecture. The components, their interfaces and behaviors are defined in architecture. The design document describes a plan to implement the requirement.

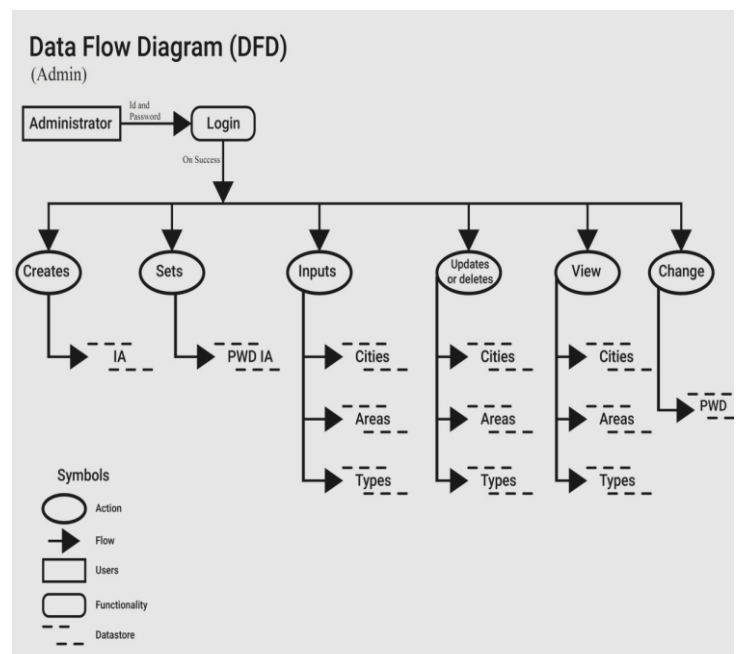

Fig2: Data Flow diagram showing communication between publisher and subscriber.

Fig2 depicts the high level design of the project i.e. dataflow diagram of the admin. Where he is one who adds the IAs and also the activities like adding the

cities, areas and view and control all the activities established in the project.

authentication verification by ID and PWD verification techniques. And adding cities areas and types and viewing all of these will be held in between Home and Server side.

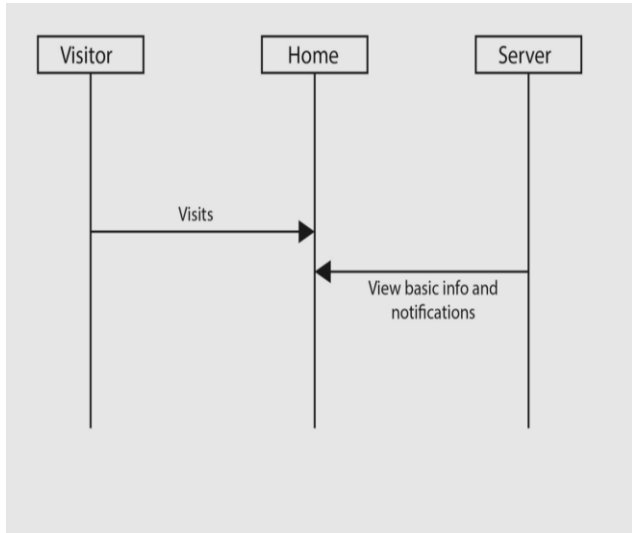

Fig3: Sequence diagram of the visitor

Fig3 explains about the activities carried out by the visitors in the project it is the public where they are notified about the recent crime details like the time and the crime occurred to the public in order to maintain precautionary measurement in their respective localities.

3. CONCLUSIONS

Real time crime intelligent system of this paper mainly focuses on the crime rate minimization and crime minimization especially in small and very small areas or localities and also the project has used the very recent technology like data mining concepts with the two trending algorithms in data mining for the development of the application.

In the lines for the further enhancement, the project is developed in more graphical and visualization concepts where the output of the crime news which will be outputted from the application can be more improvised like sending the crime trends and the

Crime rates of the respective localities to the public living in the same locality through the SMS or Mailing.

REFERENCES

- [1]S. Sathyadevan, M. Devan, and S. Surya Gangadharan, "Crime analysis and prediction using data mining," in Networks Soft Computing (ICNSC), 2014 First International Conference on, Aug 2014, pp. 406–412.
- [2]Nidhi Tomar, Amit Kumar Manjhvar, "An improved optimized clustering technique for crime detection", in symposium on colossal data analysis and networking(CDAN) 2016.
- [3] Peng Chen, Justin Kurland, "Time, place and modus operandi:A simple apriori algorithm for crime pattern detection",2018.
- [4] Shyam Varan Nath, "Crime pattern detection using data mining", oracle corporation 2017.
- [5] Chung-Hsien Yu1, Max W. Ward1, Melissa Morabito2, and Wei Ding, " crime forecasting using data mining technique", Department of Computer Science, 2Department of Sociology, University of Massachusetts Boston, 100 Morrissey Blvd., Boston, MA 02125-2018.

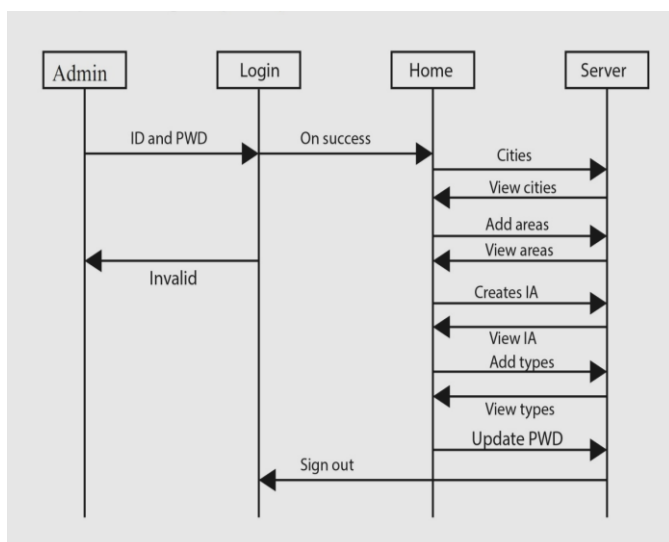

Fig4: Sequence diagram of admin part.

In the Fig4 we have again a low level diagram i.e. Sequence diagram but it depicting the sequence diagram of the admin part in the project where we have Sequence diagram of admin functionality by its communication between server with many functionalities like

[6] S.Yamuna, 2N.Sudha Bhuvanewari, "datamining technique to analyse and predict the crime", college of science coimbatore2016.

[7] S. Kaza, Y. Wang, and H. Chen, "Suspect vehicle identification for border safety with modified mutual information," in Proceedings of the 4th IEEE International Conference on Intelligence and Security Informatics, ser. ISI'06. Berlin, Heidelberg: Springer-Verlag, 2006, pp. 308–318.

[8] V. Vaithyanathan, K. Rajeswari, R. Phalnikar, and S. Tonge, "Improved apriori algorithm based on selection criterion," in Computational Intelligence Computing Research (ICIC), 2012 IEEE International Conference on, Dec 2012, pp. 1–4.

[9] C. Chu-xiang, S. Jian-jing, C. Bing, S. Chang-xing, and W. Yun-cheng, "An improvement apriori arithmetic based on rough set theory," in Circuits, Communications and System (PACCS), 2011 Third Pacific-Asia Conference on, July 2011, pp. 1–3.

[10] S. Kaza, T.Wang, H. Gowda, and H. Chen, "Target vehicle identification for border safety using mutual information," in Intelligent Transportation Systems, 2005. Proceedings. 2005 IEEE, Sept 2005, pp. 1141–1146.

[11] W. Huang, M. Krneta, L. Lin, and J. Wu, "Association bundle – a new pattern for association analysis," in Data Mining Workshops, 2006. ICDM Workshops 2006. Sixth IEEE International Conference on, Dec 2006, pp. 601–605.

[12] N. Sasaki, R. Nishimura, and Y. Suzuki, "Audiowatermarking based on association analysis," in Signal Processing, 2006 8th International Conference on, vol. 4, Nov 2006.

[13] A. Ben Ayed, M. Ben Halima, and A. Alimi, "Survey on clustering methods: Towards fuzzy clustering for big data," in Soft Computing and Pattern Recognition (SoCPaR), 2014 6th International Conference of, Aug 2014, pp. 331–336.

[14] A. Thammano and P. Kesisung, "Enhancing k-means algorithm for solving classification problems," in Mechatronics and Automation (ICMA), 2013 IEEE International Conference on, Aug 2013, pp. 1652–1656.

[15] Y. Zhao and G. Karypis, "Evaluation of hierarchical clustering algorithms for document datasets," in Proceedings of the Eleventh International Conference on Information and Knowledge Management, ser. CIKM '02. New York, NY, USA: ACM, 2002, pp. 515–524.

[Online]. Available:

<http://doi.acm.org/10.1145/584792.584877>

[16] C.-N. Hsu, H.-S. Huang, and B.-H. Yang, "Global and componentwise extrapolation for accelerating data mining from large incomplete data sets with the em

algorithm," in Data Mining, 2006. ICDM '06. Sixth International Conference on, Dec 2006, pp. 265–274.

BIOGRAPHIES



Kavya R
4VV18SCS03
#127 Shankara Nagara, near RT
Nagar, Mysore-570022.



Dr. Natesh M
Associate Professor
CSE Dept, VVCE Mysore.



Vinay MG
Assistant Professor
CSE Dept, VVCE Mysore.