

MODELING AND SIMULATION OF CONTROL SCHEME FOR ELECTRIC VEHICLE INTEGRATED WITH FUEL CELL AND SUPERCAPACITOR

Mahesh Chanda¹, Gajangi Arun Kumar², Chowdary Vinay Kumar³

¹Assistant Professor, Department of Electrical & Electronics Engineering, Mahatma Gandhi Institute of Technology

²Assistant Professor, Department of Electrical & Electronics Engineering, Mahatma Gandhi Institute of Technology

³Assistant Professor, Department of Electrical & Electronics Engineering, Mahatma Gandhi Institute of Technology

Abstract – The increase in cost and the pollution due to the usage of fossil fuels in vehicles leads to planetary problems. The automobile manufacturers have done research to solve the above problems in last three decades by developing the Electric Vehicle(EV). These vehicles created a big wave in automobile industry have been replaced the Internal Combustion driven Engines(ICE). But the main problem in these vehicles is battery setup weight and cost, they must provide energy and maximum power during the transient states which are severe condition for the batteries. The promising solution to decrease these severe conditions is the combination of SuperCapacitors(SC) and batteries associate with a good power management during the transient states and steady states. The fuel cell(FC) powered vehicle is one of the advancement for the future due to its high efficiency and capability to use hydrogen as the fuel. In this paper, the power assist control strategy and load-level control for batteries and SC's are compared. In this paper, the effective control strategy for electric vehicle using fuel cell is developed using MATLAB/SIMULINK environment and the obtained results are discussed at the end.

Key Words: Electric Vehicle, Internal Combustion driven Engines, Supercapacitor, Fuel cell

1. INTRODUCTION

To reduce the pollution due to automobiles, electrification is one of the most promising approaches, so the environment will be free from greenhouse effect gases. One of the way to get fast-refuelling time and zero emissions is Fuel Cell (FC)[1]. In present days in Fuel Cell Vehicle (FCV) advancements are vehicle recharging and management is a great challenge. EVs with a fuel cell generator intended for the average power only and it can't supply the transient load demand due to the slow internal electrochemical characteristics of the fuel cell. The utilization of energy storage devices like supercapacitors are essential for quick power delivery to meet the maximum demand. On the other hand, drive side of the EVs should employ induction motor with field-oriented vector control to avoid the problem of inherent coupling effect, which gives a sluggish response and makes the system easily prompt to instability[2].

The power changes by the traction load during acceleration and braking period may directly accelerate the ageing and degradation of the FC stack. To overcome these drawbacks, a supercapacitor(SC) is integrated to support the FC due to the excellent capability of the SC to handle dynamic peak power. The FC/SC is basically a dynamic voltage system with the passive connection. The system allows a downsized FC stack and longer durability of the FC system due to good dynamic characteristics of the SC. There is no complicated control strategies, are also obtained by eliminating the utilization of DC/DC converters.

2. FUEL CELL

Fuel cells are hardly a new idea. They were invented in about 1840, but they are yet to really make their mark as a power source for electric vehicles. However, this might be set to change over the next 20 or 30years. Certainly, most of the major motor companies are spending very large sums of money developing fuel cell powered vehicles. The basic principle of the fuel cell is that it uses hydrogen fuel to produce electricity in a battery-like device to be explained in the next section. The basic chemical reaction is:

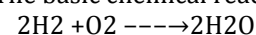

The product is thus water, and energy. Because the types of fuel cell likely to be used in vehicles work at quite modest temperatures (~85°C) there is no nitrous oxide produced by reactions between the components of the air used in the cell. A fuel cell vehicle could thus be described as zero-emission.

2.1 BASIC PRINCIPLE OF FUEL CELL:

The basic principle of the fuel cell is the release of energy following a chemical reaction between hydrogen and oxygen. The key difference between this and simply burning the gas is that the energy is released as an electric current, rather than heat. To understand how the electric current is produced, we need to consider the separate reactions taking place at each electrode. These important details vary for different types of fuel cell, but if we start with a cell based on an acid electrolyte, we shall consider the simplest and the most common type as shown in fig.2.1.

At the anode of an acid electrolyte fuel cell the hydrogen gas ionizes, releasing electrons and creating H⁺ ions (or protons).

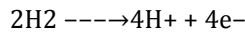

This reaction releases energy. At the cathode, oxygen reacts with electrons taken from the electrode, and H⁺ ions from the electrolyte, to form water.

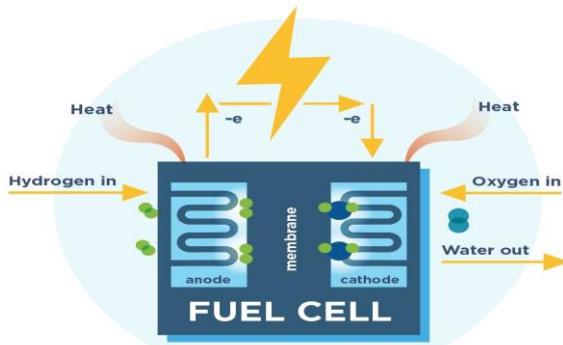
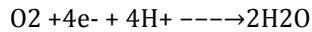

Fig.2.1.Simple Fuel Cell

3. ELECTRIC VEHICLE

3.1 Introduction to Electric Vehicles:

Vehicle operation fundamentals mathematically describe vehicle behavior based on the general principles of mechanics. A vehicle, consisting of thousands of components, is a complex system. To describe its behavior fully, sophisticated mechanical and mathematical knowledge is needed.

The tractive effort in the contact area between tires of the driven wheels and the road surface propels the vehicle forward. It is produced by the power plant torque and is transferred through transmission and final drive to the drive wheels. While the vehicle is moving, there is resistance that tries to stop its movement. The resistance usually includes tire rolling resistance, aerodynamic drag, and uphill resistance. According to Newton's second law, vehicle acceleration can be written:

$$dU/dt = (\Sigma F_t - \Sigma F_{tr}) / M_v$$

where U is vehicle speed, ΣF_t is the total tractive effort of the vehicle, ΣF_{tr} is the total resistance, M_v is the total mass of the vehicle, and δ is the mass factor, which is an effect of rotating components in the power train.

In an electric vehicle internal combustion engine and fuel tank are replaced by electric motor drives and battery packs. But batteries have a disadvantage of heavy weight, lower flexibility and performance degradation. So, we replace a battery with fuel cell.

A modern electric drive train is conceptually illustrated in Figure below. The drive train consists of three major subsystems: electric motor propulsion, energy source, and auxiliary. The electric propulsion subsystem is comprised of a vehicle controller, power electronic converter, electric motor, mechanical transmission, and driving wheels. The energy source subsystem involves the energy source, the energy management unit, and the energy refueling unit. The auxiliary subsystem consists of the power steering unit, the hotel climate control unit, and the auxiliary supply unit.

Based on the control inputs from the accelerator and brake pedals, the vehicle controller provides proper control signals to the electronic power converter, which functions to regulate the power flow between the electric motor and energy source. The backward power flow is due to the regenerative braking of the EV and this regenerated energy can be restored to the energy source, provided the energy source is receptive. Most EV batteries as well as ultracapacitors and flywheels readily possess the ability to accept regenerated energy. The energy management unit cooperates with the vehicle controller to control the regenerative braking and its energy recovery. It also works with the energy refueling unit to control the refueling unit, and to monitor the usability of the energy source. The auxiliary power supply provides the necessary power at different voltage levels for all the EV auxiliaries, especially the hotel climate control and power steering units.

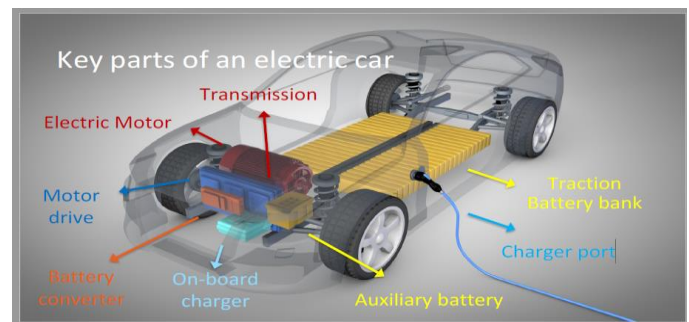

Fig: 3.1 Key parts of Electric Vehicle

3.2 Performance of Electric Vehicles:

A vehicle's driving performance is usually evaluated by its acceleration time, maximum speed, and gradeability. In EV drive train design, proper motor power rating and transmission parameters are the primary considerations to meet the performance specification. The design of all these parameters depends mostly on the speed-power (torque) characteristics of the traction motor. The motor which we have implemented is Permanent magnet synchronous motor.

4. SUPERCAPACITORS

Capacitors store electric charge. Because the charge is stored physically, with no chemical or phase changes taking place, the process is highly reversible and the discharge-charge cycle can be repeated over and over again, virtually without limit. Electrochemical capacitors (ECs), variously referred to by manufacturers in promotional literature as Supercapacitors also called ultra-capacitors and electric double layer capacitors (EDLC) are capacitors with capacitance values greater than any other capacitor type available today. Capacitance values reaching up to 400 Farads in a single standard case size are available. Supercapacitors have the highest capacitive density available today with densities so high that these capacitors can be used to applications normally reserved for batteries. Supercapacitors are not as volumetrically efficient and are more expensive than batteries but they do have other advantages over batteries making the preferred choice in

applications requiring a large amount of energy storage to be stored and delivered in bursts repeatedly.

The most significant advantage supercapacitors have over batteries is their ability to be charged and discharged continuously without degrading like batteries do. This is why batteries and supercapacitors are used in conjunction with each other. The supercapacitors will supply power to the system when there are surges or energy bursts since supercapacitors can be charged and discharged quickly while the batteries can supply the bulk energy since they can store and deliver larger amount energy over a longer slower period of time.

4.1 Super capacitor construction and equivalent circuit:

The supercapacitors different from other capacitors types by the electrodes used in these capacitors. Supercapacitors are based on a carbon (nano tube) technology. The carbon technology used in these capacitors creates a very large surface area with an extremely small separation distance.

Capacitors consist of 2 metal electrodes separated by a dielectric material. The dielectric not only separates the electrodes but also has electrical properties that affect the performance of a capacitor. Supercapacitors do not have a traditional dielectric material like ceramic, polymer films or aluminum oxide to separate the electrodes but instead have a physical barrier made from activated carbon that when an electrical charge is applied to the material a double electric field is generated which acts like a dielectric. The thickness of the electric double layer is as thin as a molecule. The surface area of the activated carbon layer is extremely large yielding several thousands of square meters per gram. This large surface area allows for the absorption of a large number of ions.

The charging/discharging occurs in an ion absorption layer formed on the electrodes of activated carbon. The activated carbon fiber electrodes are impregnated with an electrolyte where positive and negative charges are formed

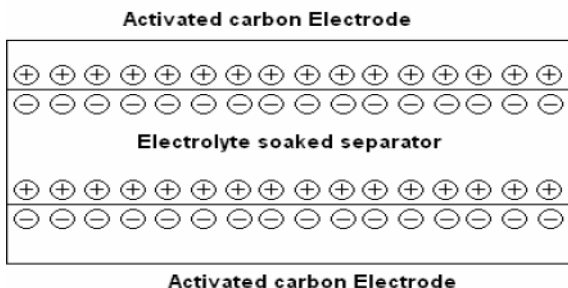

Fig.4.1 Design of Supercapacitor

between the electrodes and the impregnate. The electric double layer formed becomes an insulator until a large enough voltage is applied and current begins to flow. The magnitude of voltage where charges begin to flow is where the electrolyte begins to break down. This is called the decomposition voltage.

The double layers formed on the activated carbon surfaces can be illustrated as a series of parallel RC circuits. As shown below the capacitor is made up of a series of RC circuits where R1, R2 ...Rn are the internal resistances and C1, C2..., Cn are the electrostatic capacitances of the activated carbons.

When voltage is applied current flows through each of the RC circuits. The amount of time required to charge the capacitor is dependent on the time constant(RC) values of each RC circuit. Obviously the larger the RC the longer it will take to charge the capacitor. The amount of current needed to charge the capacitor is determined by the following equation:

$$I_n = (V/R_n) \exp(-t / (C_n * R_n))$$

Supercapacitors can be illustrated similarly to conventional film, ceramic or aluminum electrolytic capacitors.

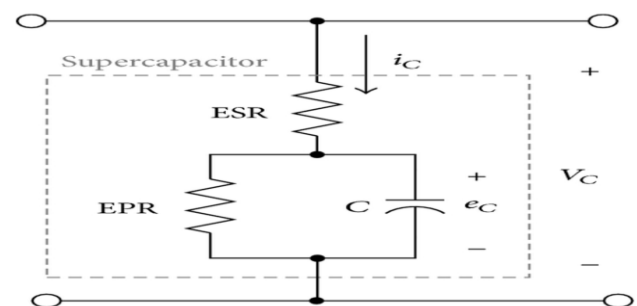

Fig.4.2. Equivalent circuit for Supercapacitor

This equivalent circuit as shown in Fig.4.2. is only a simplified or first order model of a supercapacitor. In actuality supercapacitors exhibit a non-ideal behavior due to the porous materials used to make the electrodes. This causes supercapacitors to exhibit behavior more closely to transmission lines than capacitors. Below is a more accurate illustration of the equivalent circuit for a supercapacitor.

4.2 Applications for Supercapacitors:

Supercapacitors have found uses include:

- Computer systems
- UPS systems
- Power conditioners
- Welders
- Inverters
- Automobile regenerative braking systems
- Power supplies
- Cameras
- Power generators

5. MODELING OF ELECTRIC VEHICLE USING SUPERCAPACITOR

The main objective is to develop the system which can produce undistorted currents even under unbalanced and unequal voltage conditions. In this paper, a suitable SVM

technique which can fulfill our objective and produce smooth current.

5.1.Simulation diagram of electric vehicle without supercapacitor:

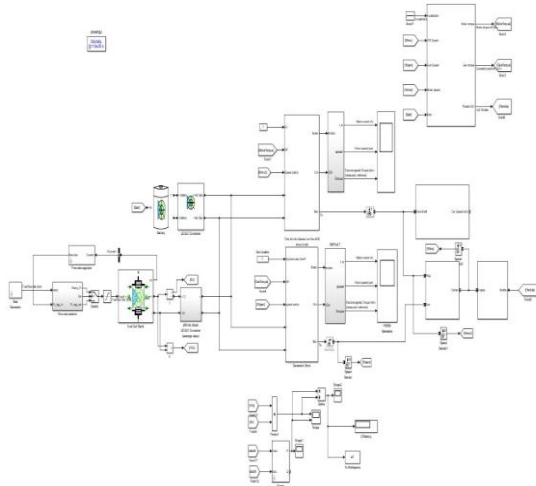

Fig.5.1.Simulink diagram of Electric Vehicle without Super Capacitor

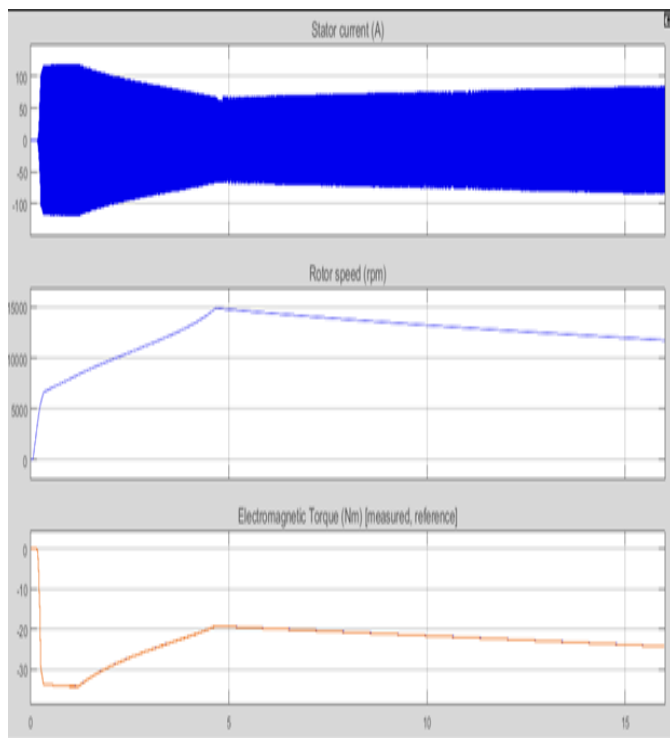

Fig.5.2.Speed-Torque characteristics of generator without Super Capacitor

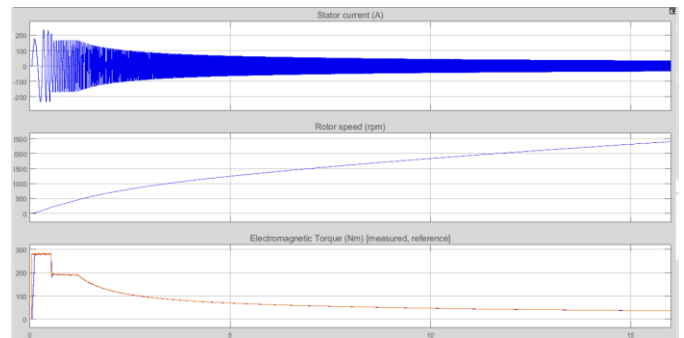

Fig.5.3.Speed-Torque characteristics of motor without supercapacitor

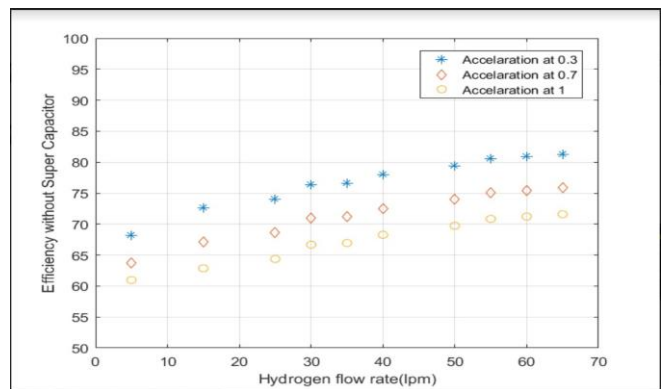

Fig.5.4. Efficiency of Electric Vehicle without super Capacitor

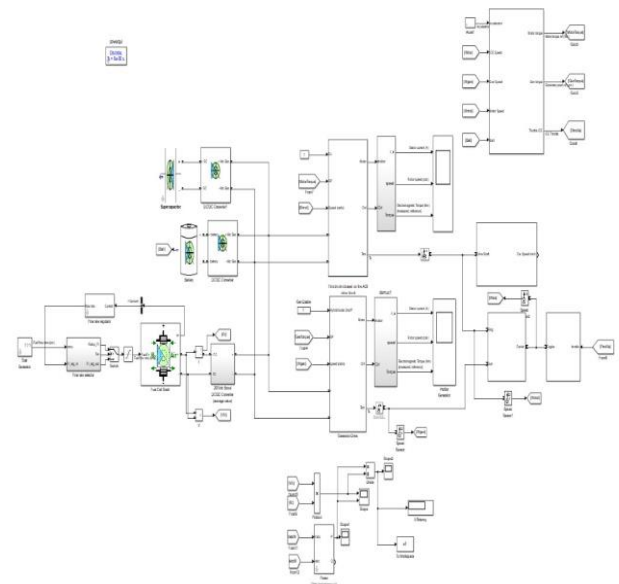

Fig.5.5.Simulink diagram of Electric Vehicle with Supercapacitor

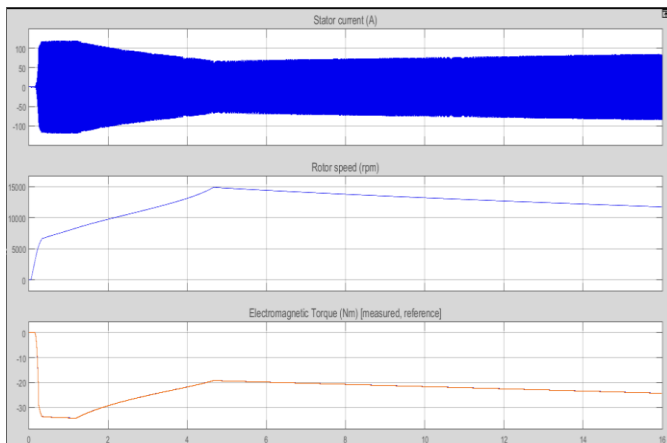

Fig.5.6.Speed-Torque characteristics of generator with supercapacitor

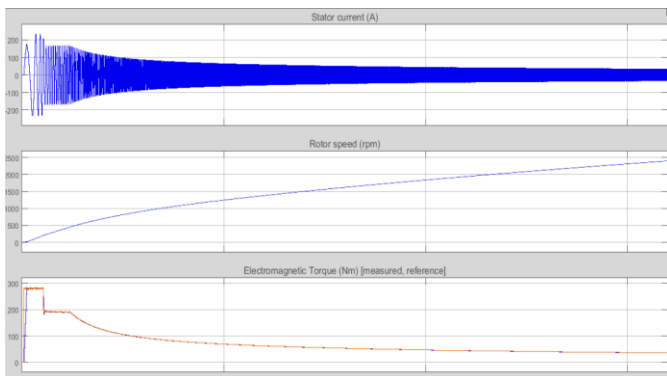

Fig.5.7.Speed-Torque characteristics of motor with supercapacitor

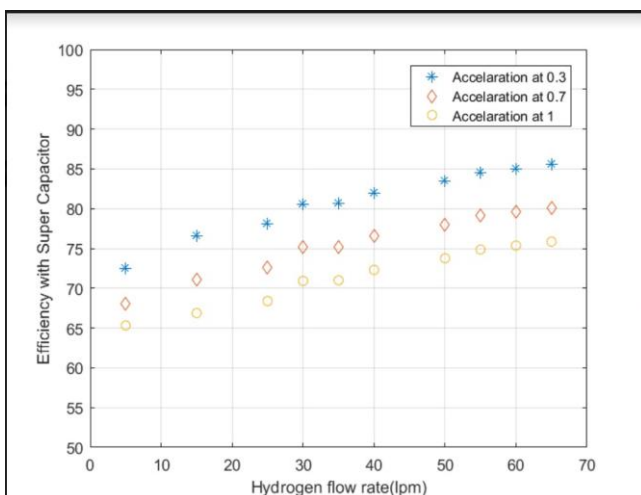

Fig.5.4. Efficiency of Electric Vehicle with supercapacitor

6. CONCLUSIONS

The efficiency of Electrical Vehicle has risen from 78% to 86% on usage of Super Capacitor at same Hydrogen flow rate. Simulation gave assurance regarding hybridization of fuel cells vehicles with supercapacitors with load leveling

control can significantly reduce the stress on fuel cells electrically and mechanically and benefit fuel economy of the vehicles. Compared to fuel cell vehicles without energy storages, fuel cell-supercapacitor hybridization achieved fuel economy increases of up to 28%. In general, the maximum fuel economy improvements are greater using supercapacitors than batteries. The power assist control strategy is better than load-level control for batteries because of the lower losses in the DC/DC converter and batteries, but load level control is better for supercapacitors. The best approach for hybridization of the fuel cell vehicles is to use supercapacitors with load levelled control as it greatly mitigates the stress on fuel cells and results in a near maximum improvement in fuel economy and fuel cell durability.

REFERENCES

- [1] Aqueel Ahmad, Mohammad Saad Alam, and Rakan Chabaan. "A comprehensive review of wireless charging technologies for electric vehicles". IEEE Transactions on Transportation Electrification 2018, no. 4, vol. 1, pp. 38-63.
- [2] V. V. Joshi, N. Mishra and D. Malviya, "A Vector Control Based Supercapacitor Current Control Algorithm for Fuel Cell and Battery - Supercapacitor Integrated Electric Vehicles," 2018 IEEE 8th Power India International Conference (PIICON), Kurukshetra, India, 2018, pp. 1-6, doi: 10.1109/POWERI.2018.8704381.
- [3] Jennifer Bauman, and Mehrdad Kazerani, A Comparative Study of Fuel-Cell-Battery, Fuel-Cell-Ultracapacitor, and Fuel-Cell-Battery-Ultracapacitor Vehicles, IEEE Transactions on Vehicular Technology, Vol. 57, No. 2, 2008, 760-769
- [4] M. Uzunoglu and M.S. Alam, Dynamic modeling, design and simulation of a PEM fuel cell/ultra-capacitor hybrid system for vehicular applications, Energy Conversion and Management 48 (2007) 1544-1553
- [5] S.J. AN, K.I. LEE, and T.J. KIM, Performance Analysis according to the Combination of Energy Storage System for Fuel Cell Hybrid Vehicle, International Journal of Automotive Technology, Vol. 9, No. 1, 2008, pp. 111-118
- [6] J. Marshall and M. Kazerani, Design of an Efficient Fuel Cell Vehicle Drivetrain, Featuring a Novel Boost Converter, in Proceedings of 2005 IEEE Industrial Electronics Conference (IECON'05), Nov. 6-10, 2005, Raleigh, North Carolina, USA.

BIOGRAPHIES



Mr. Mahesh Chanda, AMIE, MISTE received his B.Tech(2011) in Electrical & Electronics Engineering & M.Tech(2014) in Power Electronics from Jawaharlal Nehru Technological University, Hyderabad. He is currently working as an Assistant Professor in department of Electrical & Electronics Engineering, Mahatma Gandhi Institute of Technology, Hyderabad. His research areas

are micro-grid, control strategies for DC-DC Converters, multi-level inverters.



Mr. Gajangi Arun Kumar, MIE, MISTE received his B.Tech(2006) in Electrical & Electronics Engineering & M.Tech(2012) in Power Electronics & Electric Drives from Jawaharlal Nehru Technological University, Hyderabad. He is working as an Assistant Professor in department of Electrical & Electronics Engineering, Mahatma Gandhi Institute of Technology, Hyderabad. His interested research areas are electric vehicles, cyber physical systems, power quality and industrial drives.



Mr. Chowdary Vinay Kumar, MIE, MISTE received his B.Tech(2008) in Electrical & Electronics Engineering & M.Tech(2014) in Power Electronics from Jawaharlal Nehru Technological University, Hyderabad. He is pursuing his Ph.D. in Jawaharlal Nehru Technological University, Hyderabad. He is working as an Assistant Professor in department of Electrical & Electronics Engineering, Mahatma Gandhi Institute of Technology, Hyderabad. His research working areas are multi-level inverters, power quality improvement techniques and smart grid.