

FLOOD DETECTION AND EARLY WARNING SYSTEM

R.Aishwariya Lakshmi¹, M.Muthu Lakshmi¹, P.Swetha¹, Thiru D.Prakash²;

¹Final year student, B.E-Electronics and communication Engineering, S.A. Engineering College, Poonamalle, Chennai-77.

²Assistant professor, Electronics and communication department, S.A Engineering College, Poonamalle, Chennai-77.

ABSTRACT-Now a days ,natural disasters are increasing due to factors like global warming ,pollution, ozone depletion ,deforestation etc., Among many disasters, flood can be predicted and intimated priorly. In this paper, a smart device that acts as a monitoring and alarm system during flood. It comes with microcontroller(arduino) which supports for Detection & Indication which helps to control, monitor and manage the device. The device senses its local environment using onboard sensors, uploads its information to cloud and send status to administrator where the flood is going to be occurred. Based on the collected information when it finds a disaster situation, admin sends the notification immediately to the people who are located nearby areas which are going to be affected by the flood. It provides the display notifications to the user through android application .The ultimate aim of the project is to spread the Flood warning information quickly to Civilians through application.

Key words: flood detection, flood alert system, flood intimation application, water level measurement in dam

I. INTRODUCTION

The flood is abundance of water that enters and occupy the land which is usually dry. It may occur due to dam breakage, rising of water level due to excessive rain, overflow of lakes, streams, and rivers. Flood is one of the most common disasters in the world, which affects human lives and causes severe economic damage. It is found that flood risks will not decrease in the future and with the beginning of climate change, flood intensity and frequency will threaten many regions of the world . To minimize the damages caused by flood, a warning system is proposed to inform the people of the disaster should be implemented in high risk areas. This proposed system will be able to reduce the damages arises due to flood. The system should be designed to be able to detect the rising levels of water so appropriate warnings to the authorities and the public can be sent. In our paper, we classified the whole project into two parts: hardware specification and software specification. Hardware specifications hold the ultrasonic sensor (HC-SR04) for calculating the height of the water, water flow sensor (YF-S201) for calculating

the speed of outlet water and RTC Module for updating the changes in sensor periodically. The arduino uno microcontroller is used for interfacing the hardware devices and software. The above calculated data are uploaded to IOT for faster accessibility and more reliable and secure. Based on the stored data, administrator decides when to send the notification to users. For sending this information to user, we are introducing an Android Application. If the application is installed by people they will get alert notification regarding flood.

Unfortunately, there are still some lack in the significance of an early warning system which is difficult to alert the whole people in the area. Consequently, we are developing the system which is suitable to give continuous alert information to the people by notification through App at the critical situation. The majority of people who lost their lives by flood have not received any alert from the dam in charge center about the increasing water level caused by continuous rainfall and overflow of river

2. LITERATURE REVIEW

For this project, we have referred some IEEE papers to overcome disadvantages present in the below papers:

[1]Design of Disaster Management System using IoT Based Interconnected Network with Smart City Monitoring , Sumeet Hanagal, Prabodh Sakhardande, IEEE, 2016 : In this paper, IoT deals with intricate systems that integrate multiple disperse components towards their synergetic use. A system of interconnected smart modules is developed in search a way to enable centralized data acquisitions along with it will provide an interlinked network for transmission of data in absence of any existing infrastructure. The disadvantage in this paper is Separate module. Delay is large.

[2]Disaster Management System Using IOT Soubhagyalaxmi D B, Sushma L Bhosle, Swetha T, Veena P D, Chetan B V, IJRTI, 2018:In this paper,the system can be controlled and monitored from isolated location and delivering notifications based on information analysis and processing without human presences. The data stored can be utilized for future analysis. The disadvantage in this paper rather than a dedicated

application, Information is shared via G-mail or Telegram.

[3]Development of flood Prediction and Early Warning System(EWS) Nur-adib Maspo, Aizul Nahar Harun, Masafumi Goto, IJITEE, 2019: In this paper, the smart sensors used will be placed at river basin for real-time data collection on flood corelated parameter. The data will be transmitted to data center via wireless communication technology (RF) which will be processed then the information will be sent to users. The disadvantage in this paper is difficulty to design.

3. HARDWARE DESCRIPTION

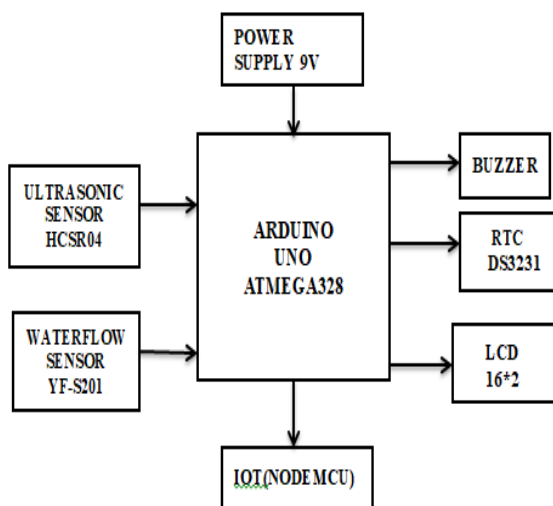

Fig-1: Block diagram

3.1 Arduino(ATMEGA)

An open source hardware device used for interfacing the all sensors and electronic devices used to perform a specific task. Any unique task can be completed by loading a set of instructions(program code) via a serial connection from the computer to arduino board . Arduino has 2 parts one is physical programmable circuit board and another one is a piece of software or IDE.This arduino software works on the computer, which is used to write and upload computer code to the physical board The Arduino boards which we are using is programmed via Universal Serial Bus (USB)which can be implemented using USB-to-serial adapter chips such as the FTDI FT232. Some boards, which are manufactured before such as later-model Uno boards, replace the FTDI chip with a separate AVR chip that holds the USB-to-serial firmware.

3.2 Power(Usb/Barrel Jack)

Every Arduino board requires a device that to be connected to a power source. Usually Arduino will use a power from computer or a wall to work, through USB cable

3.3 Ultra sonic sensor (HC-SR04)

It is an instrument used for measuring the distance form object using sound waves. An ultrasonic sensor which is a transducer that sends and receives the ultrasonic pulses that relay back information about an object's proximity. This device is mainly suitable for moisture content area .

3.4 Water flow sensor

A sensor that fixed in line with water line and contains a rotatingwheel sensor , measure how much water has moved through it. an integrated magnetic hall effect sensor that outputs an electrical pulse with respect to each revolution. The hall effect sensor is fixed in the water pipe and allows the sensor to stay safe and dry. on counting the pulses from the sensor output, we can easily calculate water flow environmental friendly material is used which doesn't produce any hazard when it used in water.

3.5 Liquid crystal display(LCD)

Usually LCD is a combination of two states of matter, one is solid and another is liquid. LCD uses a liquid crystal to produce a visible image LCD modules will have a seven segments and other multi segment LEDs.

The reasons for selecting LCD's are more economical, have no limitation for displaying special and even custom characters, easily programmable, usage is simpler usually 16x2 LCD is preferred,which will be used which will display 16 characters per line and displays in 2 lines. In this LCD, each character can be displayed in 5x7 matrix pixel. Basically LCD consists of two registers, one is Command and another is Data. the command register is mainly used for storing the command instructions given to the LCD. The data register is basically used for storing the data which will be displayed on the LCD.

3.6 Buzzer

Buzzer or beeper, a device which is used for audio alerting, it may be electromechanical, mechanical, or piezoelectric (piezo for short). Usage of buzzers in alarm devices, confirmation of user input such as a keystroke, timers and mouse click

3.7 Real Time Clock(RTC)

A device is preferred to update the obtained sensor values periodically with the accurate time. It runs with a dedicated battery.

3.8 Node MCU

It is a hardware module which transmits the updated value to the cloud with the measured time continuously. This value is the input of the software section. It gets automatically updated when a new value is being obtained by the sensors. Internet connection is required for a faster data rate transmission.

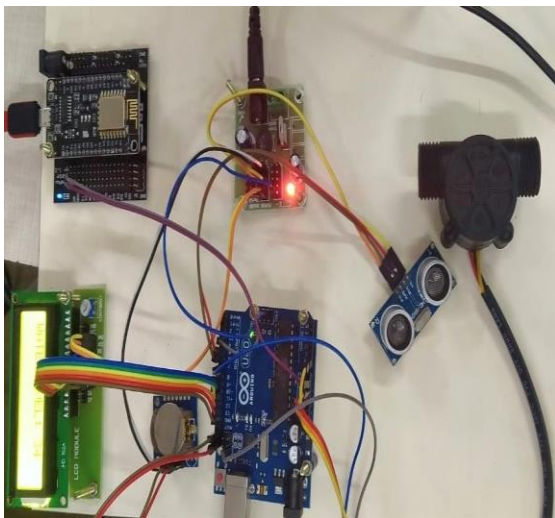

Fig-2: Hardware kit

4.SOFTWARE DESCRIPTION:

- Arduino ide.
- Embedded c
- Android studio

4.1 Arduino ide

The Arduino Integrated Development Environment - or Arduino Software (IDE) - contains a text editor for a message a text console, coding. It connects to the Arduino and Genuino hardware to upload programs and communicate with them.

4.2 Embedded c

Each processor present in electronic system is associated with embedded software. Embedded C programming plays a important role in performing specific function by the processor.

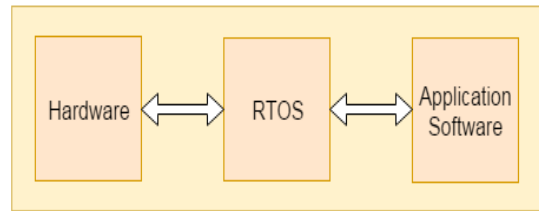

Fig-3:embedded format

4.3 Android studio:

4.3.1 XML:

eXtensible Markup Language(XML) is markup language created as a standard way for encoding the data in internet-based applications. XML is used for android applications to create layout files. Unlike HTML, XML is case-sensitive, requires each tag be closed, and preserves whitespaceMarkup languages are designed for the processing, definition and presentation of text. The code for layout and style, used to specify the formatting are called tags.

4.3.2 JAVA:

It is one among the popular programming languages used to create Web applications and platforms. It is designed for adaptability, allowing developers to write code that would run on any machine, regardless of architecture or platform Used to produce a platform neutral code. Compilation is a onetime exercise and execute faster.

4.3.3 PHP:

PHP stands for Hypertext Pre-processor .It's an open source, server-side, scripting language used for the development of web applications. PHP stands for Hypertext Pre-processor, that earlier stood for Personal Home Pages.PHP scripts can only be interpreted on a server that has PHP installed. Runs on different platform easily.

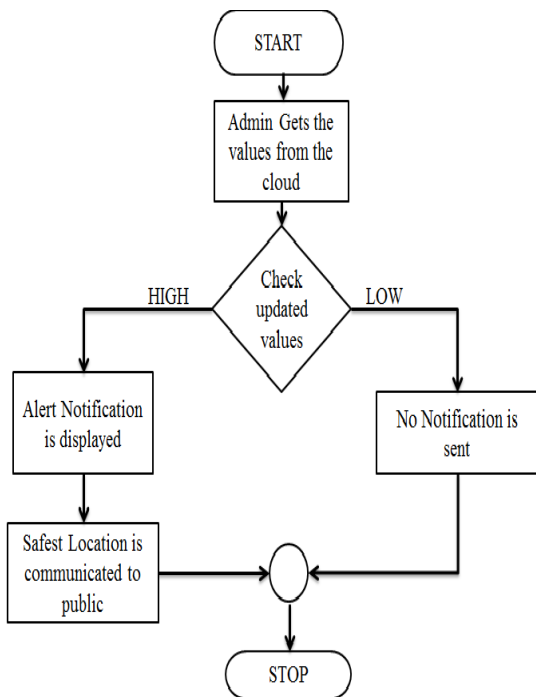

Fig-4: Flow chart

5. MODULES:

- Login / Registration.
- Database Creation.
- Monitoring
- Exit

5.1 Login & registration:

In our module we design to develop login and signup page. Android used xml to develop classical screen in our application. The modules will have signup page contains email id as user name, password and confirm password those kind of details should be stored in database. When the user wants to enter the app .he/she must enter the user name and password .the entered data should match the already stored data. If it is same the user can go through it otherwise alert the user and show a message to the user.

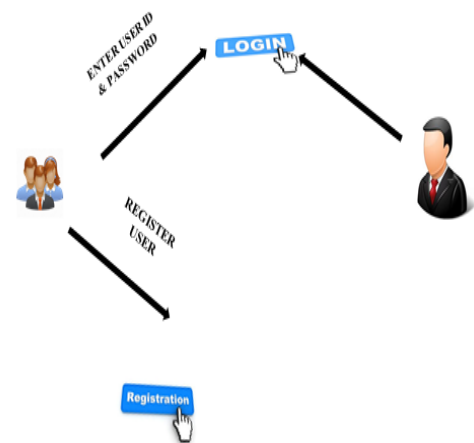

Fig-5: Login page

5.2 Database creation:

User-id (Registered Number), username, password, mobile number, address have been stored in MySQL database using php function and JSON. Generally android should has its own inbuilt database named as Cloud Database. But it cannot store the value in cloud.so only we use php and json for storing and retrieving the data in cloud using our Android application.

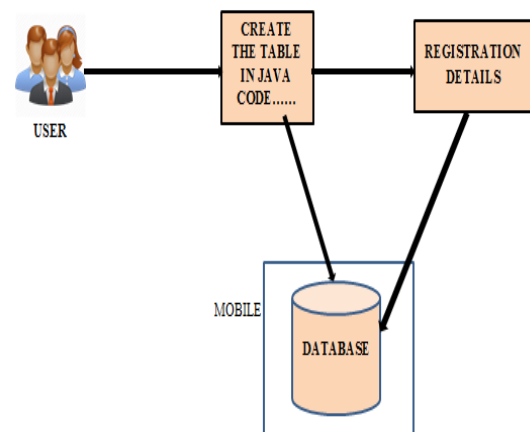

FIG-6: Database creation

5.3 Monitoring

In this module we have to develop an input value from embedded output for android input value we can monitor the mobile apps so we are using android application.



FIG-7: monitoring process

5.4 Exit

When you decided to quit our application simply click “Home” button and it will go directly to the home page where you click “Exit” button to exit our application.

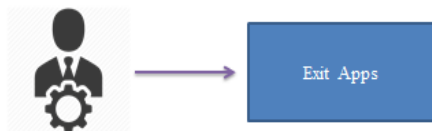

FIG-7 Exit

6. WORKING

6.1 Hardware working



FIG-8: initial status

Initially the water level of the respective dam is measured using an Ultrasonic Sensor (HCSR04) which has both Transmitter and Receiver embedded in it. By using certain frequency and time taken, the distance of the water level from the sensor is calculated and the value is made to display on the 16*2 LCD. Depending on the distance, the message is obtained accordingly i.e. if the distance is less than the critical value, the flood detected message is displayed. This is because, if the water level is way too high, there is a chance of breaking of the dam, which collapses the entire construction leading to huge loss.



Fig-9: Status 2 flood detection

The other aspect where the flood can be detected is by the flow of the water (Litres per cubic metre). If the water flow is high, the water goes beyond the river beds causing flood to the regions nearby. This may take place mostly during rainy seasons because of the continuous inflow of water to the dam from various sources. During this situation, the officials are forced to make the water flow out of the dam in large quantity to avoid any critical damage to it. Here, a Water Flow Sensor (YFS201) is installed in the canals where the water flows with full speed. If the speed exceeded the limit and the time for which it flows then there is definitely a possibility of Flood. During this process, the prevailing method is that, an alarm keeps on ringing by which the locals would come to know that the dam is made to open. Even then, they would not know that the water may affect them unless it reaches their house. Else only the measured distance is displayed in the LCD.



FIG-10: Status 3

The Arduino board (UNO ATMEGA 328) is a microcontroller which interfaces the hardware and stores the data in the cloud and retrieves the data for further processing. When the value from the Ultrasonic sensor and the Water Flow sensor is found, those data are made to be displayed on the LCD and then stored on the cloud. The LCD is for the Reference purpose. A Buzzer is also interfaced with the Arduino so that rural

people who don't know to apply any technology can get prior intimation through this kind of noise. These people use water from these rivers for their daily purpose and it is very much dangerous if they are in the flood prone region. Hence this kind of Intimation is required in this case. It is always useful for small areas.

A Real Time Clock (RTC) is also being interfaced with the Arduino. Its major purpose is to store the data obtained from the sensors with the accurate date & time. This plays a vital role in predicting the flood which is a risky procedure. By comparing the data at particular interval of time and knowing the difference, we can 80% predict the occurrence of flood priorly which is a major advantage of this application. If the difference between the present value and the previous value increases rapidly or in a steady manner, we can conclude that there is a possibility of the flood.

6.2. Software working

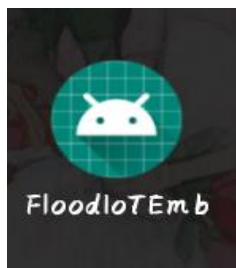

Fig-12: App symbol

The above figure is an icon that will be displayed in the mobile for indicating the flood alert application.

ADMIN:

The output from the hardware section is given as the input to the software where the values are stored in the cloud using IOT. The admin can log into the application and can monitor the updated values. If the value is high, then the alert button in the page is pressed which gives the alert notification to the people who has that app and the safest location is shared to the priorly. The languages used for developing is XML & JAVA.

A special ID and Password is given for the administrator for accessing the admin page of the application. Only if the value of the flow sensor is very high than the actual value, the admin can press the alert button which is exclusively present in the page. Else, there is no need to press the button as there won't occur any disaster. The person who is present there must know the average water flow level to correctly manage the application or else false information is sent to the

people which make them feel dishonesty about the app for further notifications.

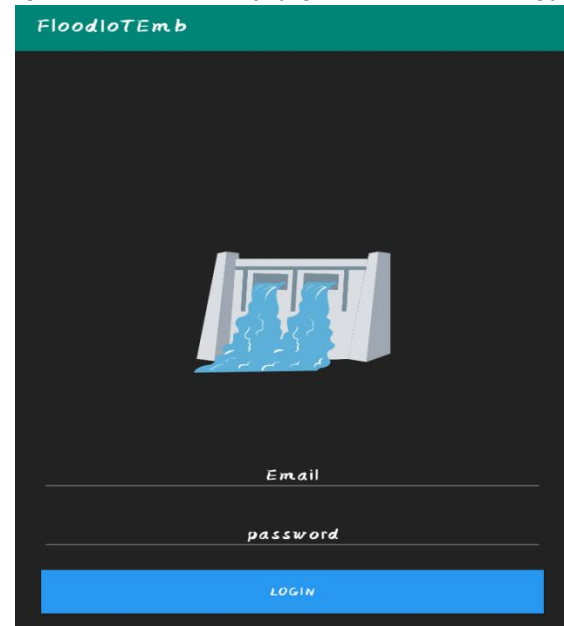

Fig-13: Registration page

A certain dam is considered and its parameters are included and monitored periodically in regular days. During heavy rainy days, the dam should be continuously monitored 24/7 by officials to avoid any great mishaps occurring in the area. The admin should be highly cautious during this time because the region around the dam is highly prone to the flood and much precious life can be lost because of a single person's carelessness



Fig-14: Admin page

USER

After the intimation is given by the admin , a notification pops on the notification screen with an alarming sound. On the other hand, if the mobile is in silent mode, a vibration is provided along with the pop up message. Thus, the users should realize the present situation and should act accordingly. The location where the people should vacate is also displayed on the app. So, the public co-operation is also very important

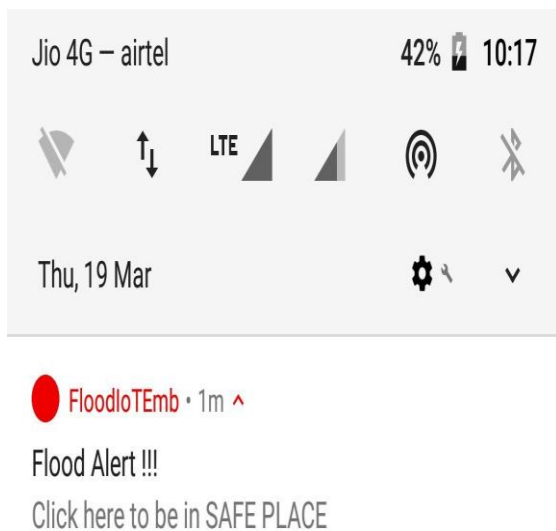

Fig-15: Alert notification

for this process to work properly, the users should periodically check the app once in a while, For eg. Once in a Day. This can prevent many losses occurring.

7. RESULT

The alert notifications are sent to the public before the occurrence of the flood so that they can locate to another area at a safe time.

8.FUTURE SCOPE

A Laser Range Finder can be implemented instead of Ultra Sonic Sensor which is more precise and costly. All the hardware connections can be made wireless with the help of certain frequency (IR). Information can be uploaded without the usage of internet by connecting two wifi routers which is more reliable. The overall size can be reduced and can be implemented in a small chip using future technologies. Any loss of data during transmission can be reduced using advanced CSMA/CA techniques. The bit rate can be improved for certain level.

9. CONCLUSION

In this project automation is implemented in the field of dam without any human intervention. The process is fast and can alert the people prior to the occurrence of the flood. Because of this, we can save numerous lives and the process is also easy and is also predictable.

REFERENCE

[1] Elizabeth Basha¹, Daniela Rus²: "Design of Early Warning Flood Detection Systems for Developing Countries" - International Conference on Information and Communication Technologies and Development (ICICTD) - 2007 ISSN 2394 - 3386 Volume 5, Issue 4 April 2018.

[2] Izzatdin Abdul Aziz¹, Izyan Ahmad Hamizan², Nazleeni Samiha³, Haron⁴, Mazlina Mehat⁵: "Cooperative flood detection using GSM via SMS" - Institute of Electrical and Electronics Engineers (IEEE) - 2008 doi: 10.1109/ITSIM.2008.46345.

[3] Ponthip Limlahapun¹, Kanagawa², Japan Hiromichi Fukui³: "Flood monitoring and early warning system integrating object extraction tool on web-based" - Institute of Electrical and Electronics Engineers (IEEE) - 2009

[4] Prabodh Sakhardande¹, Sumeet Hanagal²: "Design of Disaster Management System using IOT Based Interconnected Network with Smart City Monitoring" - Institute of Electrical and Electronics Engineers (IEEE) - 2016 doi: 10.1109/IOTA.2016.7562719

[5] Soubhagyalaxmi D B¹, Sushma L Bhosle², Swetha T³, Veena P D⁴, Chetan B V⁵: "Disaster Management System Using IOT" - International Journal for Research Trends and Innovation (IJRTI) - 2018.