

Numerical Investigation of Folded Flange Section with Variation in Aspect Ratio

Venkatesh Pravin Kumar S¹, Dr. A. Murugesan², Senthil Kumar E³

¹PG Student, Department of Civil Engineering, Sona College of Technology, Salem, Tamil Nadu, India

² Associate Professor, Department of Civil Engineering, Sona College of Technology, Salem, Tamil Nadu, India

³ Assistant Professor, Department of Civil Engineering, Muthayammal Engineering College, Namakkal, Tamil Nadu, India

Abstract - Cold Formed steel is one of the emerging construction techniques due to its high efficiency of strength to weight ratio. Folded Flange section is an open Channel section with folding at both the end of the flange. This article deals with the Numerical Analysis of folded flange section with aspect ratio (i.e., depth to width ratio) of 1, 1.5 and 2. It is found that when the aspect ratio increases the section fails at earlier stage due to distortional failure. There are no significant changes in load bearing capacity of the section.

Key Words: Cold formed steel, Distortional buckling, Torsional buckling, Local buckling.

1. INTRODUCTION

Cold formed steel which is also known as light gauge section are best known for its efficiency on the part of strength to weight ratio. Due to its ability to carry comparatively high load at a very lower self-weight, because of which its usage is increasing now a days. The dead load of the building gets reduced ultimately. This gives an added advantage for structural engineers to design the building easily and very economical compared to Hot rolled structures. The CFS sections are highly sensitive to distortional, local and lateral torsional buckling. [1]

Break pressing and roll forming are the main method of fabricating the cold formed steel section. The thickness of the pain sheet ranges from 0.5 mm to 7 mm in thickness in industrial standards.[2] It also gives the flexibility of forming various shapes and sizes of cross section. They are also very easy to handle at on-site and easier to connect between the sections. [3]

Folded flanged section is a kind open channel section in which end of flanges are folded. This paper targets to Numerical investigation of folded flange section on its variation in depth to width ratio. The depth ratio of 1, 1.5 and 2 are investigated in this paper. The Numerical investigation is carried out by using ABAQUS.

2. MATERIAL PROPERITIES

Properties of cold formed steel is studied by tensile coupon test. Tensile test coupon is being cut from the cold formed

sheet. The tensile test specimen dimensions are according to IS 1608: 2008. Totally three specimens were prepared and tested by using UTM of 200 kN capacity. At the ends of the specimen friction marks were made to avoid slippage from the UTM. The Coupon test setup is shown in Fig 1. By using the deflectometer, deflection was noted down. The Stress vs Strain curve is shown in Chart 1. The properties of Cold formed steel are tabulated in Table 1.



Fig 1. Tension Coupon Test Setup

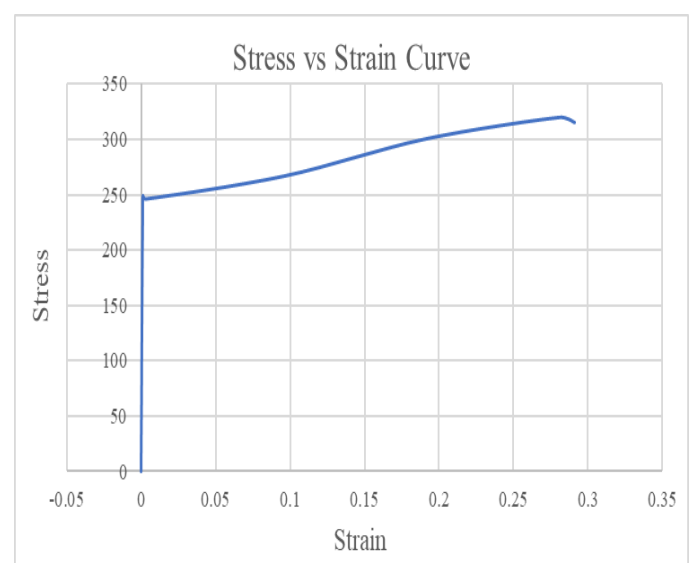

Chart 1. Tensile coupon specimen - Stress-strain graph

Table 1. Mechanical properties of cold-formed steel

Modulus of elasticity, E	$2.062 \times 10^5 \text{ N/mm}^2$
Poisson's ratio, μ	0.3
Yield stress, f_y	249 N/mm^2
Ultimate stress, f_u	319.56 N/mm^2
Density, ρ	0.007962 kg/mm^3

3. SECTION GEOMETRY

Investigation is conducted for three Folded Flanged section with variation in depth to width ratio. The sections are FF - 1, FF - 1.5 and FF - 2 with aspect ratio i.e., depth to width ratio as 1, 1.5 and 2 respectively. Flange dimension and folded part dimension are constant for all the section. Only the web section dimensions are varied. Table 2 shows the Nominal dimensions of the specimen. Fig 2 shows CADD model of specimen.

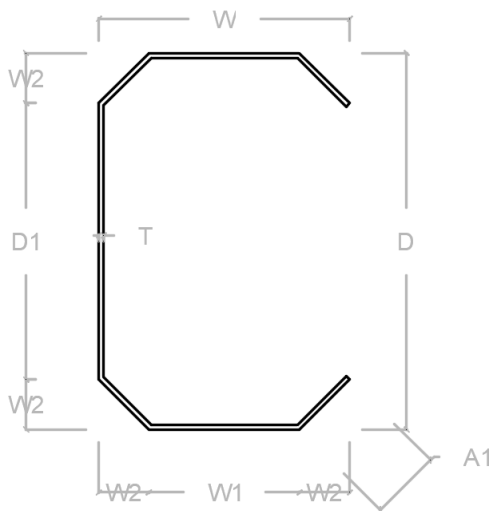

Fig 2. CADD model of specimen

Table 2. Nominal dimensions of specimen

Specimen ID	D	W	D1	W1	W2	A1	T
FF - 1	100	100	60	60	20	28	2
FF - 2	100	150	110	60	20	28	2
FF - 3	100	200	160	60	20	28	2

All dimensions are in mm

4. NUMERICAL ANALYSIS

Finite element method is numerical method of analyzing problems. In this method the structure is divided into small elements of simple geometry and assembled together. Here Finite Element Analysis is carried out by using ABAQUS 6.11 software. The software includes a series of modules. The work flows as Part module, Property module, Assembly module, Step module, Interaction module, Mesh module and Job module.

The section is initially modelled in the Part module. And then the property of the section shown in Table 1 is given in feed. Fig 3 shows the model the section. Then in Assembly module, for analysis requirement the section to has to be in Simply supported condition with two-point loading condition. To achieve this one support condition is assumed to Fixed and other end support condition as Roller support. For Fixed condition U_x , U_y and U_z are restrained. For Roller support U_x and U_y are restrained. Loads are applied as concentrated loads at different nodes at distance of $1/3\text{rd}$ of length from both the end support. The model is divided into separate small elements in Mesh module. Then the section is submitted for analysis in Job module. Fig 4(a), 4(b) and 4(c) shows the Stress contour of the section FF - 1, FF - 1.5 and FF - 2 respectively.

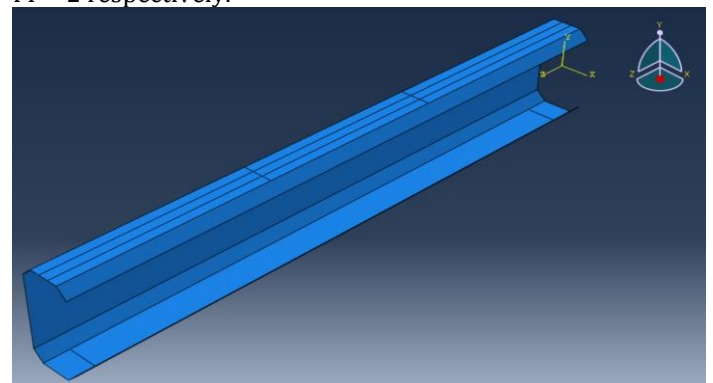

Fig 3. Model of specimen

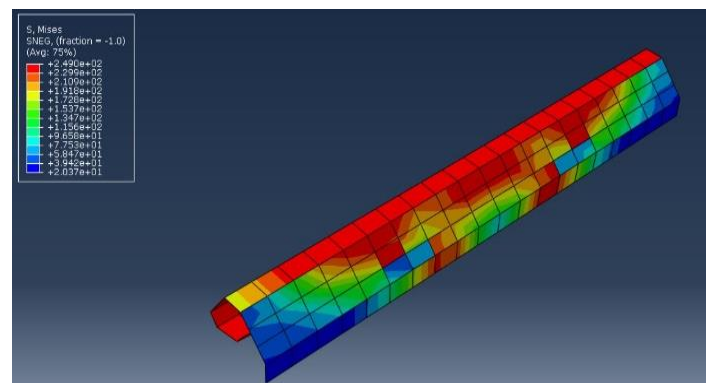

Figure 4(a). Stress contour of FF - 1

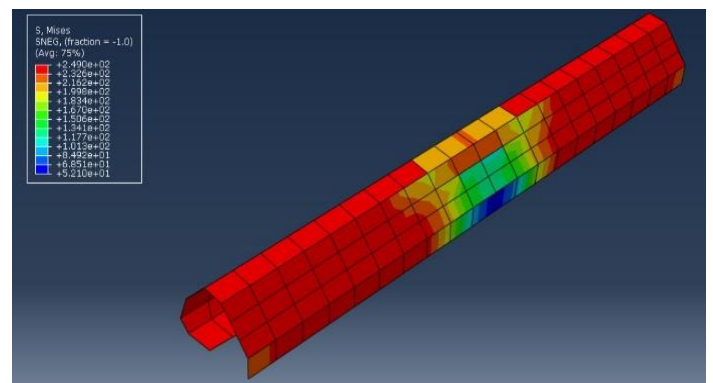

Figure 4(b). Stress contour of FF - 1.5

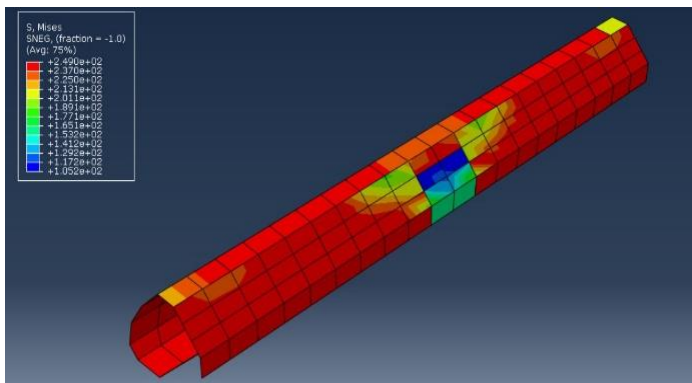

Figure 4(c). Stress contour of FF - 2

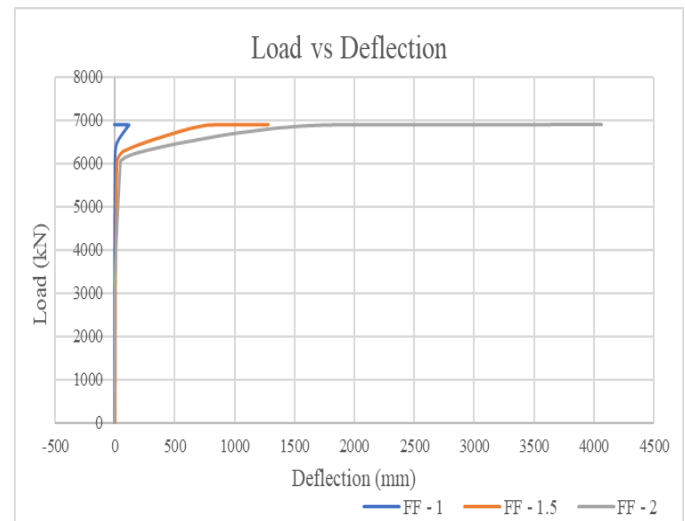

Chart 3. Load vs Deflection curve

5. RESULTS AND DISCUSSIONS

The results are obtained from the Numerical analysis of the folded flange section at two-point loading condition. The load bearing capacity for the sections FF - 1, FF - 1.5 and FF - 2 are same of 6.90 kN. The load bearing capacity of the section is shown in Chart 2. But it observed that when the depth to width ratio increases the section fails due to Distortional failure. It is because shear centre and the centroid do not coincide with each other in open channel sections. When the aspect ratio i.e., depth to width ratio increases the deflection of the top flange also increases. The Load vs Deflection curve is shown in Chart 3.

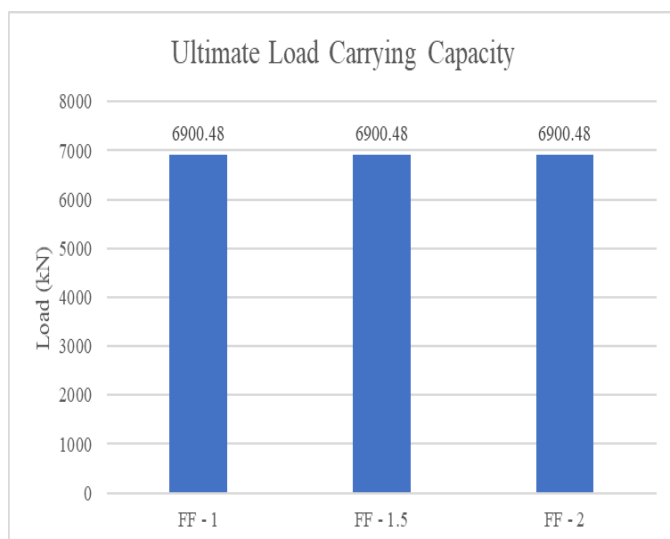

Chart 2. Ultimate Load Bearing Capacity

6. CONCLUSIONS

Numerical analysis has been carried out for the section FF-1, FF - 1.5 and FF - 2 from the analysis the following conclusions are been made.

- In open section since the shear centre and centroid do not coincide the section fails at early stage due to Distortional failure.
- When the aspect ratio increases the deflection of the top flange also increases. This is one of the reasons for the load bearing capacity not increasing with aspect ratio.

REFERENCES

- [1] Srinath T and Shanmugurajan M B, "Effect of Web Opening on the Bending Behaviour of Cold Formed Built up I Section", International Journal of Science, Environment and Technology, Vol. 5, No. 1, 2016, PP. 102 - 110.
- [2] Dr. J. Jegan, J. Prasath (2016), 'Behaviour of Built - Up Cold Formed Steel Sections', International Journal of Advanced Engineering Research and Technology (IJAERT), Vol.4, Issue 4.
- [3] Jun Ye, Seyed Mohammad Mojtabaei, Iman Hajirasouliha, Paul Shepherd, Kypros Pilakoutas (2018), 'Strength and Deflection Behaviour of Cold-Formed Steel Back-To-Back Channels', Engineering Structures Vol.177, PP.641-654.
- [4] IS 1608:2005 (Part - 1). Metallic Materials - Tensile Testing at Ambient Temperature.
- [5] IS 801:1975. Code of Practice for use of Cold Formed Light Gauge Steel Structural Members in General Building Construction.