

Wavelet Entropy Threshold Logic Based Transmission Line Distance Protection

Sunil N. Gandhare¹, Dr. Prema Daigavane²

¹PG Scholar, Electrical Engineering Department, G H Raisoni College of Engineering, Nagpur

²HOD, Electrical Engineering Department, G H Raisoni College of Engineering, Nagpur
Maharashtra, India

Abstract - Most of faults occur in transmission line of power system. It is requirement of any protection to protect the transmission line as early as possible. Transmission line is normally design for transfer extra high voltage from one location to another location. Maximum portion of transmission line is always exposed in environmental condition. If faults in transmission line is continue then which may damage transmission line or power system stability. Relay is the one of the protecting device which detect the fault condition in transmission line and send trip signal to circuit breaker for isolate the transmission line. Normally relays in India are working on fundamental components of transmission line voltage and current. And relay required at least one cycle of fundamental frequency of transmission line parameter. This paper present, the transmission line protection system using threshold logic based and wavelet spectral analysis based system. The transmission line receiving ends current are measured and send to the wavelet multi-resolution analysis filtering bank. Based on spectral energy threshold logic of three phase current of transmission line. Trip signal generated for circuit breaker operation during abnormal condition of line.

The complete protection scheme transmission line model is design in MATLAB 2015 simulink software. Result and testing of simulation model done in modeling. It is observed that system is protected very fast and efficiently during fault conditions

Key Words: MRA, Spectral Energy, Threshold Logic, Distance Protection

1. INTRODUCTION

An adaptive filter is a computational device that attempts to model the relationship between two signals in real time in an iterative manner. An adaptive filter is defined by four aspects as the signals being processed by the filter, the structure that defines how the output signal of the filter is computed from its input signal, the parameters within this structure that can be iteratively changed to alter the filter's input output relationship. The adaptive algorithm that describes how the parameters are adjusted from one time instant to the next. The problem of combining fast fault clearance with selective tripping of plant is a key aim for the protection of power

systems. To meet these requirements, high speed protection systems for transmission and primary distribution circuits that are suitable for use with the automatic reclosure of circuit breakers are under continuous development and are very widely applied. Distance protection, in its basic form, is a non-unit system of protection offering considerable economic and technical advantages

In power systems, many kinds of faults and abnormal operating conditions may occur. The most common, and also the most harmful, are short circuits of different kinds. Short circuit current can damage equipment of power systems, reduce the voltage of relevant pans of the system, and even threaten the stability of the system. Faults are not only caused by lightning, wind, ice, earthquake, fire, explosions, falling trees, flying objects, physical contact by animals and other natural events, but are also caused by equipment failure, incorrect operation etc. Irrespective of the cause, faults must be isolated quickly and selectively. For this purpose, protective relays are installed at different parts of a power system.

2. PROPOSED METHODOLOGY

2.1. Block diagram

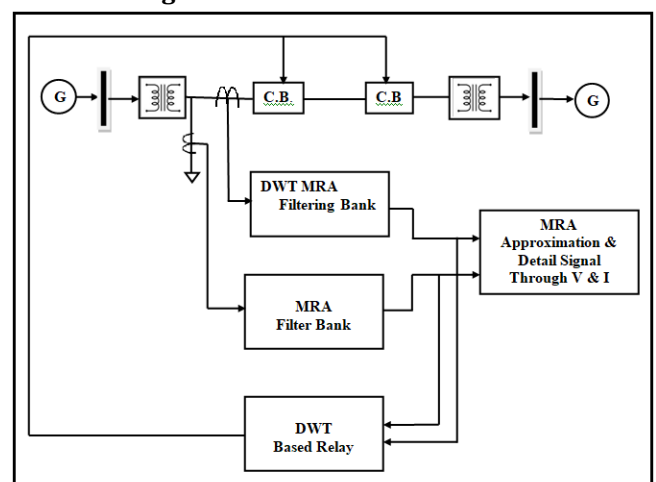

Fig-1: Block diagram of proposed approach

Figure 1 shows the block diagram of distance protection of transmission line. In the working of proposed approach of the system, the generator 'G' generates electricity which coupled to the three phase step up transformer. After that, it will be supplied to the transmission line.

V-I measurement block measures the voltage and current signals of three phase transmission line. These signals get analyzed by using discrete wavelet transform so that we get information about time and frequency of the signal.

These voltage and current signals applied to the discrete wavelet transform multi-resolution analysis filtering bank. Where the multi-resolution analysis will be held at the voltage and current signal, in which we select desired particular band of frequency. For different fault condition, we calibrate values for voltage and current signal. From this, we calculate set energy value and in different conditions, we take different voltage and current values and by this calculate their energy value. These energies at different conditions and our set energy will be compared. If the energy calculated is higher or lesser than that of set energy value then the fault generated and the DWT based relay will send the trip signal to the circuit breaker and the circuit will break.

2.2 Simulation model

Figure 2 shows the MATLAB simulation model of proposed wavelet entropy spectral analysis based distance protection scheme for transmission line. Distributed PI model of transmission line utilized for designing of model. Transmission line receiving end three phase current are measured and send to the wavelet multi-resolution analysis subsystem model.

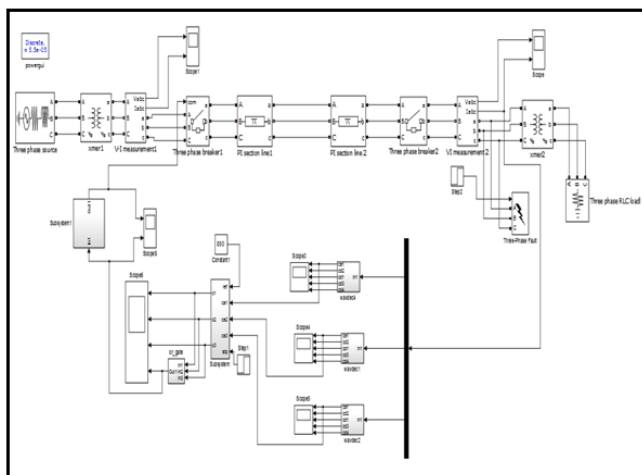

Fig-2: Matlab simulation model of wavelet entropy based distance protection scheme

Table-1: MATLAB Simulation Parameter Specification

Sr. no.	Name of Block	Parameters
1	Three phase source	Phase -to- phase rms voltage (v)PPV=153e3, Phase angle of phase A(degrees)=0, Frequency(Hz)= 50Hz, Three phase short-circuit level at base voltage (VA)PVa=100e6,

		Base voltage (Vrms ph-ph)bv=34.5e3, X/R ratio=7
2	Three phase transformer 1(two winding)	Nominal power in VA =50e6, nominal frequency in hertz=50, Phase -to -phase nominal voltage in volts RMS for winding 1=34.5e3, resistance in per unit for winding1=0.002, leakage inductance in per unit for winding 1=0.08, Phase -to -phase nominal voltage in volts RMS for winding 2=10e3, resistance in per unit for winding2=0.002, leakage inductance in per unit for winding 2=0.08, Magnetization resistance Rm(Pu)=500 Magnetization inductance Lm(Pu)=500
3	Three phase breaker	Breaker resistance Ron(ohms)=0.001, Snubber resistance Rp(ohms)=1e6, Snubber capacitance Cp (farad)=Inf.
4	Three phase PI section line	Frequency used for rlc specification(Hz)=50, Positive and zero sequence resistance r1=0.01273ohms/km, Positive and zero sequence resistance r0= 0.3864 ohms/km, Positive and zero sequence inductance L1= 0.9337e-3(H/km), Positive and zero sequence inductance L0=4.1264e-3(H/km), Positive sequence capacitance C1=12.74e-9 (F/km), Zero sequence capacitance C0=7.751e-9(F/km), Line length(Km)=5
5	Three phase series RLC load	Nominal ph-to-ph voltage Vn(Vrms)=440, Nominal frequency Fn(Hz)=50, Active power P(W)=10e6, Inductive reactive power QL (positive Var=0, Capacitive reactive power Qc (negative Var)=0
6	Three phase	Nominal power in VA=50e6

	transformer2	Nominal frequency=50, Phase -to -phase nominal voltage in volts RMS for winding 1=10e3, resistance in per unit for winding 1=0.002, leakage inductance in per unit for winding 1=0.08, Phase -to -phase nominal voltage in volts RMS for winding 2=440, resistance in per unit for winding 1=0.002, leakage inductance in per unit for winding 1=0.08 Magnetization resistance Rm(Pu)=500 Magnetization inductance Lm(Pu)=500
7	Three phase fault	Fault resistance Ron(ohms)=1e-9, Ground resistance Rg(ohms)=0.001, Initial status of fault of phase =0, Initial status of fault of phase B=0, Initial status of fault of phase C= 1, Snubber resistance Rp(ohms)=1e6, Snubber capacitance Cp(farad)=inf
8	Step2	Step time= 0.3, Initial value=0, final value=1, Sample time=Ts

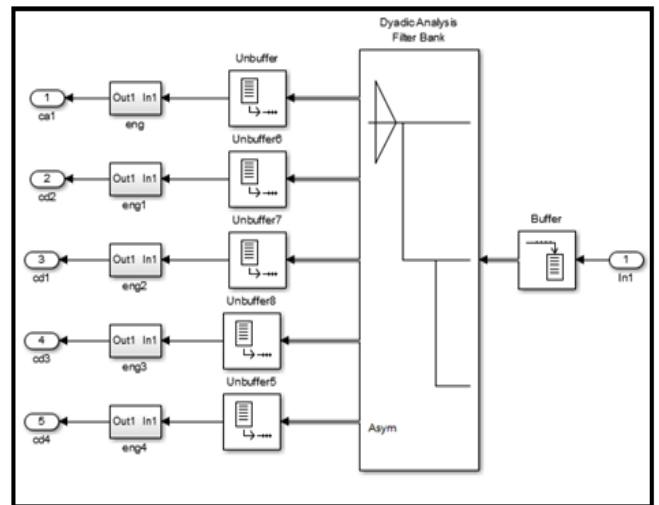

Fig-3: Wavelet multi-resolution analysis subsystem model

Then again after multi-resolution analysis we get Detail D1, D2, D3, D4 and Approximation A4 coefficient as frame output of dyadic filtering bank. That frame output again converter into scalar output by using Unbeffer block shown in figure 3. Finally Detail D1, D2, D3, D4 and Approximate scalar signal coefficient spectral energy calibrated using spectral energy calibration simulink subsystem block which connect at each output of multi-resolution analysis block (MRA). Then that calibrated spectral energy of each detail and approximation signal is send to the threshold comparison subsystem for generation of trip signal. Table 2 shows the parameter specification for wavelet transform subsystem which is shown in figure 3.

Table-2: Wavelet Transform subsystem parameter specification

Sr.no.	Name of Block	Parameters
1	Buffer	Output buffer size(per channel)=64, Buffer overlap=0, Initial condition= 0
2	Dyadic analysis filter bank	Filter= Haar, No of levels=4, Tree structure= Assymmetric, Output= multiple port
3	Unbuffer	Initial condition=0

2.3 Wavelet Transform Subsystem

Three phase current at receiving end of transmission line is send to the wavelet multi resolution analysis subsystem model. In which first input three phase current is converted into scalar signal to frame output of 64 channels. Then after using dyadic analytic filter bank as multi-resolution filtering bank analyzed the frame input signal. The Haar mother wavelet with 4 level of multi-resolution analysis utilized for analyzed the three phase current frame input.

2.4 Threshold logic subsystem

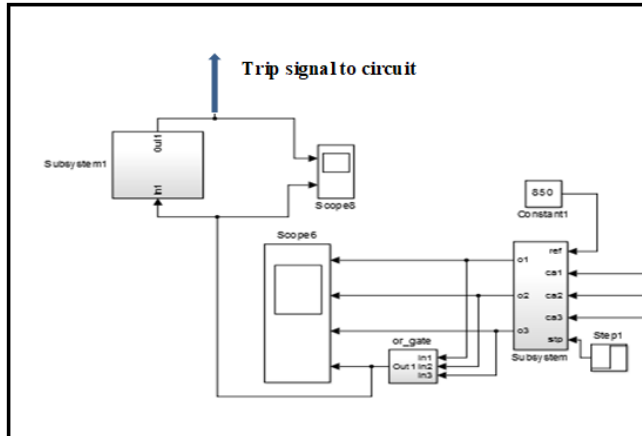

Fig-4: Threshold logic subsystem for trip signal generation

Figure 4 shows the threshold logic subsystem in which spectral energy pf approximation signal of each three phase current signal which calibrated in MRA analysis wavelet subsystem model. During normal condition it is calibrated from simulink model, 830 is normal spectral energy value of each three phase approximation spectral energy. Hence each phase approximation energy is compared with 830 using relational operation less than or equal to sign. During fault condition the spectral energy is always greater than 830 spectral energy values. That's why 830 is the spectral energy threshold value for generation of logic 1.

If any phase current approximation spectral energy is greater than 830 values then output O1 to O3 will be 1 depends on which phase higher.

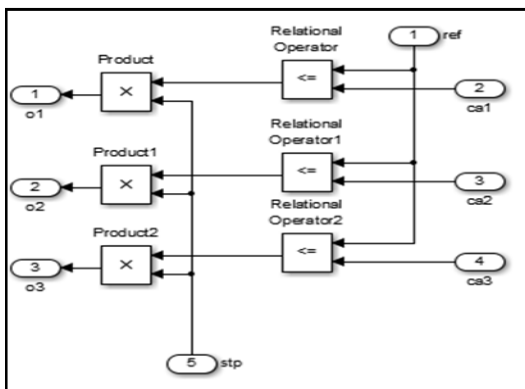

Fig-5: Spectral Energy comparator subsystem using OR gate

3. EXPERIMENTAL RESULTS AND DISCUSSION

3.1 Normal Condition

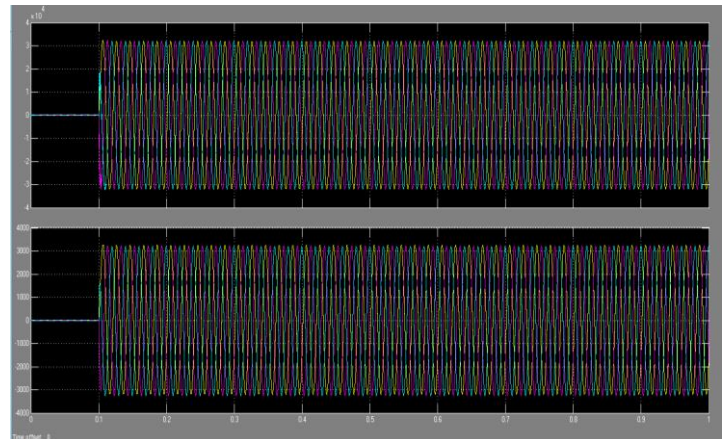

Fig-6: Three-phase reciving end voltage and current signal at normal condition

Figure 6 shows the three phase receiving end voltage and current waveform in which X axis shows the simulation time in seconds while upper Y axis shows the voltage in KV and lower Y axis shows the current in Amp. It observed that during normal condition, when line supplied at 0.1 Sec simulation time the three phase voltage and current waveform are rated without any fluctuations.

Figure 7 shows the Spectral energy calibration window of reciving end phase current A using multi-resolution analysis at normal condition in which it is observed that spectral energy of phase A current approximation signal is below 830 i.e approximately 755. While figure 7 shows the spectral energy calibration locus in which X axis represent time in seconds while Y axis divided into five axis scale in which first scale show the approximation 4 signal spectral energy, second axis shows the detail D1 spectral energy, third axis shows the detail D2 spectral energy, fourth axis shows the D3 spectral energy and fifth axis shows the D4 spectral energy locus with respect to time axis. These axis parameters are same for figure 10, 13 and 16.

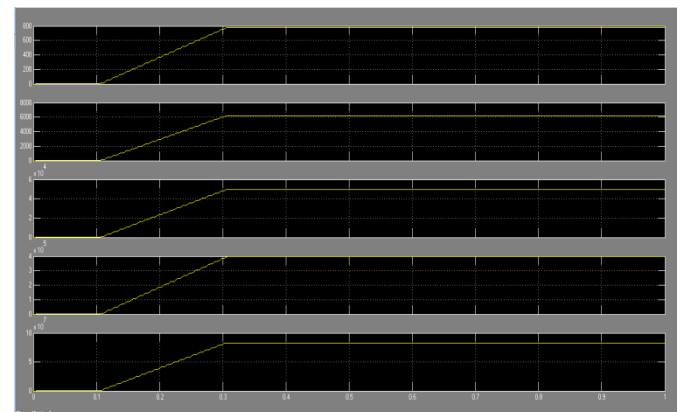

Fig-7: Signal energy calibration window of reciving end phase current A using multi-resolution analysis at normal condition

Figure 8 shows the window for logic generated after threshold logic subsystem as well as lower axis shows the trip signal for circuit breaker. It is observed that there are no any trip signals or logic generated during normal condition. Hence no any circuit breaker operation occurs during normal condition.

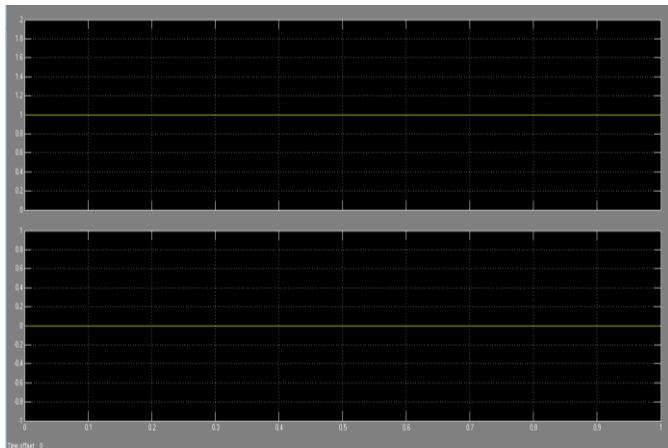

Fig-8: Relay generated trip signal at normal condition without fault

3.2 Single line to ground fault

Figure 9 shows the three phase receiving end voltage and current waveform in which X axis shows the simulation time in seconds while upper Y axis shows the voltage in KV and lower Y axis shows the current in Amp. It observed that during line to ground fault condition, when line supplied at 0.1 Sec simulation time the three phase voltage and current waveform are rated without any fluctuations but after 0.3 second three current increases and voltage decreases from rated values. At 0.3 second line to ground fault takes place in phase A to ground of transmission line using three phase fault simulink block.

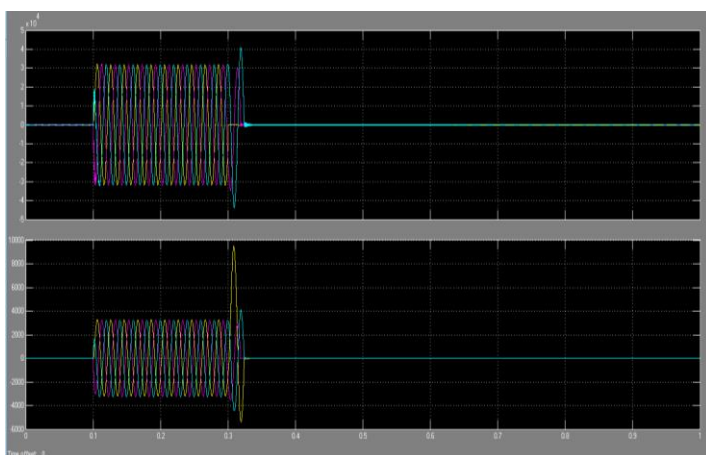

Fig-9: Three-phase receiving end voltage and current signal at single phase to ground fault

Figure 10 shows Signal spectral energy calibration window of receiving end phase current B using multi-resolution

analysis at line to ground fault. It is observed that at 0.3 sec when fault occurs at phase A then spectral energy of approximation of phase A is more than 830 threshold value.

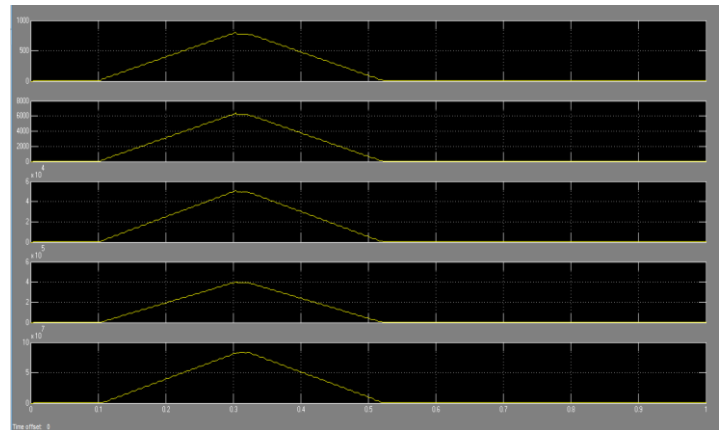

Fig-10: Signal energy calibration window of receiving end phase current B using multi-resolution analysis at line to ground fault

Figure 11 shows that Relay generating trip signal at single phase to ground fault condition in which upper window shows the threshold logic generated at 0.3 sec while a trip square wave signal generated at 0.3 second for trip the circuit breaker.

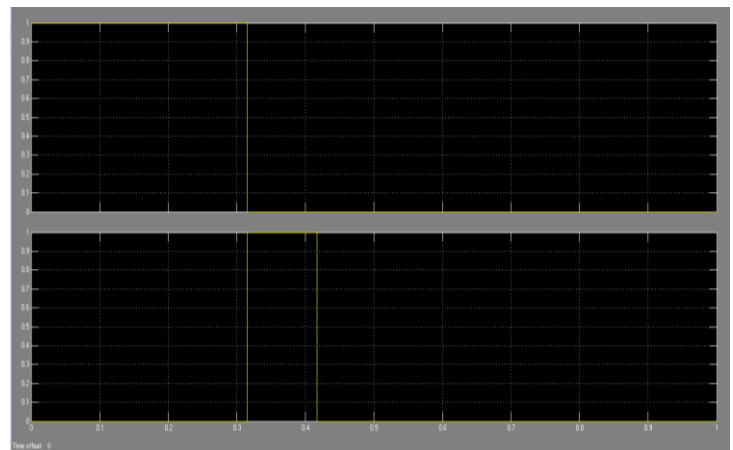

Fig-11: Relay generating trip signal at single phase to ground fault condition

From figure 11 it is clear that at 0.3 sec the circuit breaker is open the transmission line for isolation of line to ground fault condition and protect the line from short circuit current in phase A.

3.3 Double phase to ground fault

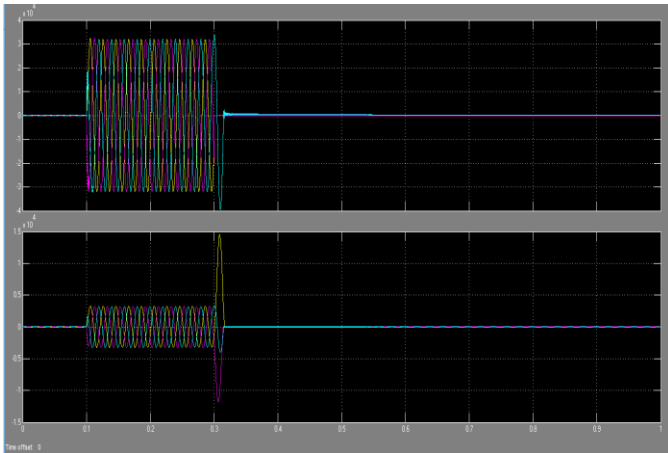

Fig-12: Three-phase receiving end voltage and current signal at double phase to ground fault

Figure 12 shows the three phase receiving end voltage and current waveform in which X axis shows the simulation time in seconds while upper Y axis shows the voltage in KV and lower Y axis shows the current in Amp. It observed that during double line to ground fault condition, when line supplied at 0.1 Sec simulation time the three phase voltage and current waveform are rated without any fluctuations but after 0.3 second three phase current increases and voltage decreases for faulted phases of line from rated values. At 0.3 second double line to ground fault takes place in phase b and c to ground of transmission line using three phase fault simulink block

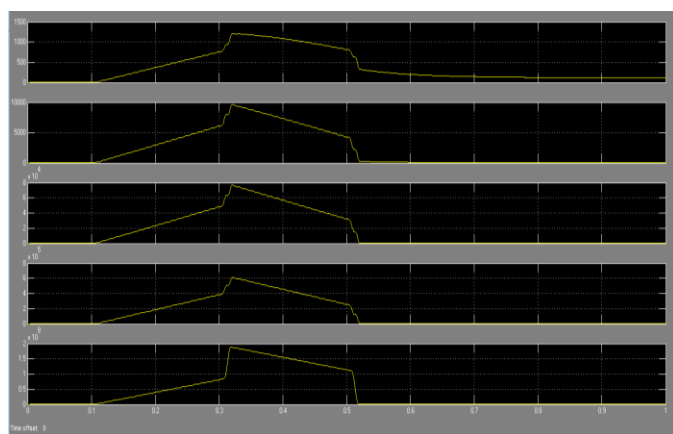

Fig-13: Signal energy calibration window of receiving end phase current A using multi-resolution analysis at double line to ground fault

Figure 13 shows Signal spectral energy calibration window of receiving end phase current A using multi-resolution analysis at line to ground fault. It is observed that at 0.3 sec when fault occurs at phase B and C then spectral energy of approximation of phase B and C is more than 830 threshold value.

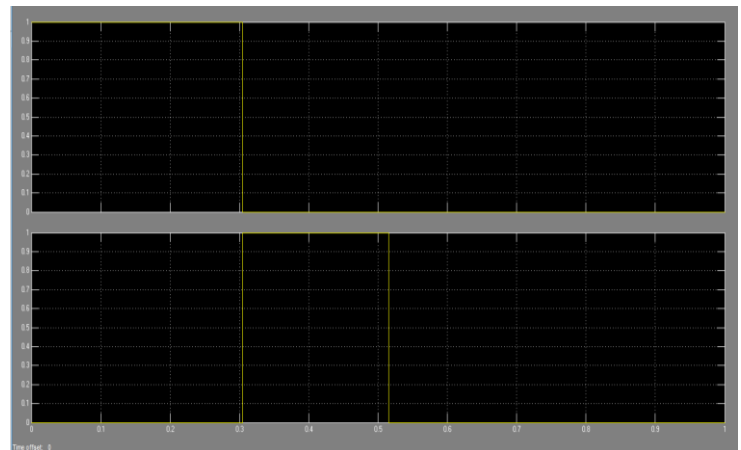

Fig-14: Relay generating trip signal at double phase to ground fault condition

From figure 14 it is clear that at 0.3 sec the circuit breaker is open the transmission line for isolation of double phase line to ground fault condition and protect the line from short circuit current in phase B and C.

3.4 Three phase symmetrical fault

Figure 15 shows the three phase receiving end voltage and current waveform in which X axis shows the simulation time in seconds while upper Y axis shows the voltage in KV and lower Y axis shows the current in Amp. It observed that during double line to ground fault condition, when line supplied at 0.1 Sec simulation time the three phase voltage and current waveform are rated without any fluctuations but after 0.3 second three phase current increases and voltage decreases for all three phases of line from rated values. At 0.3 second three phases to ground fault takes place in all three phases to ground of transmission line using three phase fault simulink block.

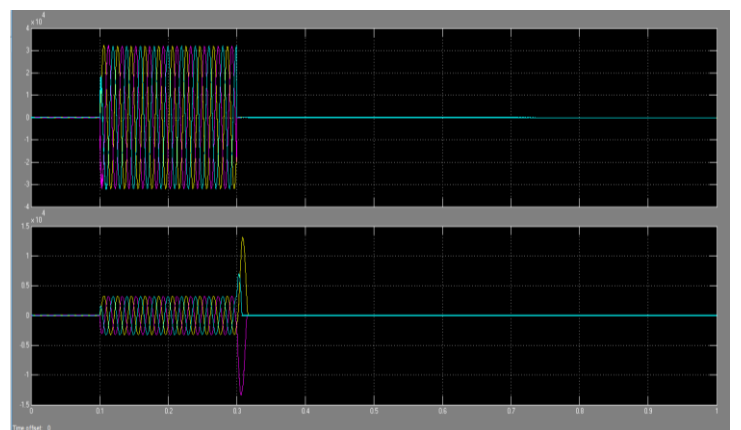

Fig-15: Three-phase receiving end voltage and current signal at three phase to ground fault

Figure 16 shows Signal spectral energy calibration window of receiving end phase current B using multi-resolution analysis at three phase to ground fault. It is observed that at

0.3 sec when fault occurs at three phase to ground then spectral energy of approximation of all three phases are more than 830 threshold value.

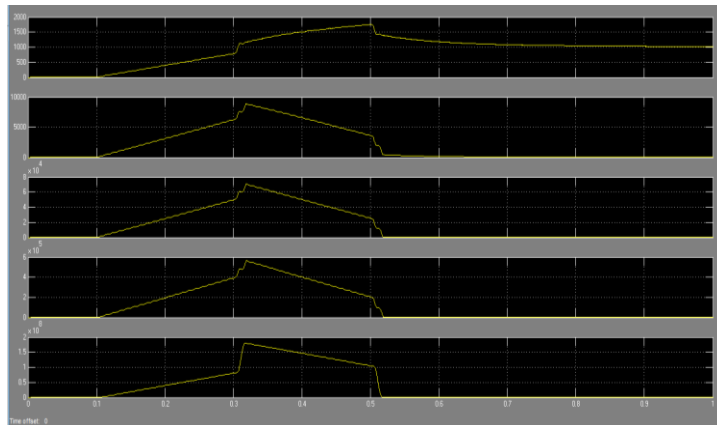

Fig-16: Signal energy calibration window of receiving end phase current B using multiresolution analysis at three phase fault

From figure 17 it is clear that at 0.3 sec the circuit breaker is open the transmission line for isolation of three phase to ground fault condition and protect the line from three phase short circuit current in all three phases of transmission line.

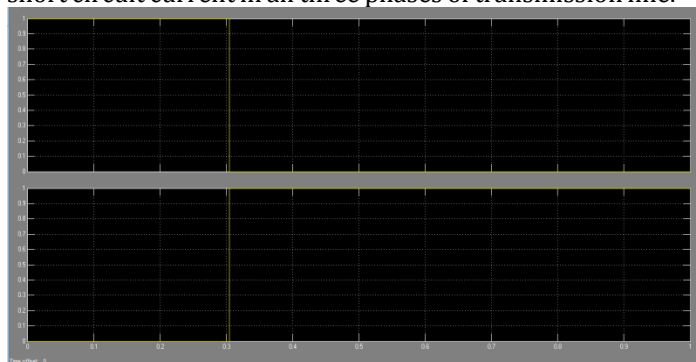

Fig-17: Relay generating trip signal at three phase to ground fault condition

4. CONCLUSION

This paper present transmission line protection using distance relay based on wavelet analysis spectral energy of current signal of three phase transmission line. The transmission line receiving ends current are measured and send to the wavelet multi-resolution analysis filtering bank. Based on spectral energy threshold logic of three phase current of transmission line. Trip signal generated for circuit breaker operation during abnormal condition of line.

From result it is clear that, transmission line is protected from different faults like line to ground, double line to ground, double line fault and three phase symmetrical faults in short duration of time. These protection schemes are very fast and take only 3 micro second time for detection of fault condition. The fast operation is possible due to signal analysis using wavelet multi-

resolution analysis and comparative threshold spectral energy system.

REFERENCES

- [1] hing Shan Chen, Chih- Wen Liu and Joe-Air Jiang "Application of combined adaptive fourier filtering technique and fault detector to fast distance protection", IEEE Trans. on Power delivery, Vol. 21, No.2, pp. 619-626, April 2006.
- [2] C-Hamon, T.J.Nicolai, D.A.Myers "Microprocessor based relays improve distribution system reliability of high profile customer", IEEE Trans. pp. c3 1-4.
- [3] A.G.Phadke, J.S.Thorp, M.G.Adamiak "A new measurement technique for tracking voltage phasor system frequency rate of change of frequency", IEEE Trans. on power apparatus and systems, Vol. PAS-102, No. 5, pp. 1025-1038, May 1983.
- [4] M.S. Sachdev, M.A. Baribeau "A new algorithm for digital impedance relays", IEEE Trans. on power apparatus and system, Vol. PAS-98, No.6, pp. 2232-2240, Nov./ Dec. 1979.
- [5] Jyh-Cherng Gu, Sun-Li-Yu "Removal of De offset in current and voltage signals using a novel fourier filter algorithm", IEEE Trans. on power delivery, Vol. 15, No. 1, pp. 73-79 Jan. 2000.
- [6] Jun-Zhe Yang, Chih-Wen Liu, "Complete estimation of DC offset in current signals for relaying applications", IEEE Trans., pp.1933-1938,2000.
- [7] K.K.Li, L.L.Lai, " An adaptive window length algorithm for digital distance protection", Proceedings of 4th international conference on advances in power system control, operation and management, APSCOM-97, Hong-Kong, pp.83-88, Nov. 1997.
- [8] Jun- Zhe Yang, Chin- Wen Liu, "A precise calculation of power system frequency and phasor", IEEE Trans. On power delivery, Vol-15, No 2, PP 494-499 April 2000.
- [9] Joe-Air Jjiang, Ching-Shan Chen, Chih-Wen Liu, "A new protection scheme for fault detection, direction discrimination, classification, and location in transmission lines", IEEE Trans. on power delivery, Vol. 18, No.-1, PP 34-42, Jan 2003.
- [10] Sheng Su, Xianzhong Duan, Xiangjun Zeng "ATP based automated fault simulation", IEEE Trans. on power delivery, Vol.23, No.3, pp.-1687-1689, July 2008.
- [11] A.H.Osman, O.P. Malik "Wavelet transform approach to distance protection of transmission lines", IEEE Trans. pp.115-120, 2001.
- [12] Chul- Hwan Kim, Hyun Kim, Young-Hun Ko, Sung-Hyun Byun, Raj K. Aggarwal, Allan T. Johos, "A novel fault detection technique of high impedance arcing faults in transmission lines using the wavelet transform", IEEE Trans. on power delivery, Vol. 17. No.4, pp.921-929, October 2002
- [12] A.P. Sakis Meliopoulos, Chien-H Sing Lee "An Alternative method for transient analysis via wavelet", IEEE Trans. on power delivery, Vol. 15, No.1, pp.114-121, January 2000.