

Comparative Study on Effect of Different Configuration of Horizontal Bracings on the Performance of Elevated Water Tank

Anik N Soniwala

¹PG Student, Structural Engineering, Department of Civil Engineering, L.J.I.E.T, Ahmedabad, Gujarat, India

Abstract - Fluid-structure interaction is one of the most perplexing phenomenon in dynamic analysis of elevated water tank. Earthquakes are one of the major natural calamities which have a potential to stop the normal going life of human by causing damage to infrastructure and lifeline facilities. Elevated water tanks should not collapse even after the earthquake since they are essential for supplying drinking water and quenching fires. Earthquake is the major natural phenomenon which can cause harm to human life directly disturbing the infrastructure and necessary facilities around us. From the past experience of few earthquakes occurred, during earthquake it is observed that the elevated storage reservoirs were collapsed or damaged and this might have occurred due to various reasons like lack of understanding the behavior of the supporting structure (staging) of the reservoir due to seismic loading or selection of improper geometric shape of the staging structure. Framed staging pattern is widely used for the elevated storage reservoir. In this study, an attempt has been made to study the behavior of the reinforced concrete elevated storage reservoir with different horizontal bracing patterns under seismic conditions. The analysis of elevated water tank is carried out in STAAD PRO.

Key Words: Horizontal Staging, Elevated Water Tank, Framed Staging, Staad Pro .

1. INTRODUCTION:

Water tank is used to store water for daily requirement of the human being. Water is the life line for every kind of creatures in this world. To secure constant water supply from longer distance with sufficient static head to the desired location under the effect of gravitational force, the elevated water tanks are necessary. Fluids are stored in different structures like underground water tanks, ground supporting water tanks and elevated storage water tanks with these structures, elevated water tanks are mostly use for the circulation of fluid under pressure for chemicals, storing water, inflammable fluids etc. The cost and expenditure of steel water tank is more as compare to other material water tanks and so they are infrequently used for water tanks. Reinforced concrete water tanks can be made economical, have monolithic behavior in nature and can be made watertight by their plain design and construction. Different types of bracings configurations can be provided to

the staging for adequate resistance of seismic forces. Storage water tank with various types of bracings configurations in horizontal plane is studied.

1.1 Classification of Watertank:

The water tanks are classified according to the type of heads as:

- 1) Watertank Placed on Ground
- 2) Elevated Water tanks rest on Staff or Staging
- 3) Underground Water Tanks.

The Water Tanks are classified according to their shapes as:

- 1) Circular water tank
- 2) Rectangular water tank
- 3) Spherical Water tank
- 4) Intz type Water tank
- 5) Circular Water tanks with conical dome

1.2 Components Of Intz Type Water Tanks:

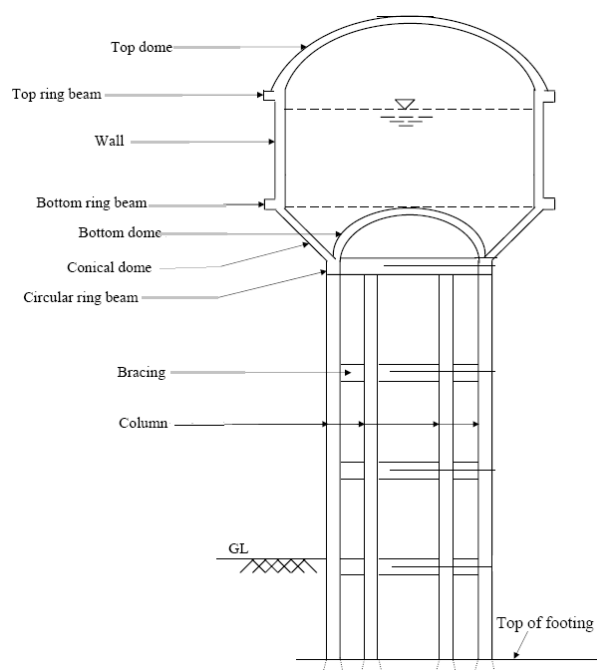

1.3 Aim & Objective of Study:

- Aim of the study is to, 'To Study the Behavior of Elevated Water Tank with Different Lateral Load Resisting Structural Systems'.
- The basic objective is to study the Behavior of Elevated water tank with different lateral load resisting structural system.
- To study the various effects on performance of Elevated water tank with different horizontal configuration of bracing system.
- To compare the analysis results in terms of time period, base shear and base moment.

1.4 Scope of Work:

- To study various literature available related to Elevated water tank.
- Guidelines from IS 1893 part-1, IS 1893 Part-2, IS 3370, IS 456, IS 11682, IS 875 will be followed during the procedure.
- To Study performance of Elevated water tank with different lateral load resisting system.
- 18 Lac litre E.S.R intze type water tank is considered to be situated in Ahmedabad- Seismic Zone III, water tank is considered to be resting on Medium type soil, water tank is considered as SMRF.
- Each model will be analysed for full, Partially filled and empty condition.
- Formulae and values will be taken from IS 1893:2014.

2. Analysis of Intz Type Water Tank

1) Methodology:

- Load Calculations Using MS Excel.
- FEM based software STAAD.Pro is used to find out Lateral stiffness of staging.
- Comparison of Different Horizontal Braced Configurations.

2) Modelling And Analysis of Watertank for earthquake:

- Two mass model idealization of the Intze type water tank is more appropriate as compared to a one-mass idealization. Two-mass idealization model for elevated storage reservoir was proposed by Housner (1963) and it is being commonly used in most of the international codes and also in IS code 1893(part 2):2014. The pressure generated within the fluid due to the dynamic motion of the tank can be separated into impulsive and convective parts. When a tank containing liquid with a free surface is subjected to horizontal earthquake ground motion, tank wall and liquid are subjected to horizontal acceleration. The liquid in the lower region of tank behaves like a mass that is rigidly connected to tank

wall. This mass is termed as impulsive liquid mass which accelerates along with the wall and induces impulsive hydrodynamic pressure on tank wall and similarly on base Liquid mass in the upper region of tank undergoes sloshing motion. This mass is termed as convective liquid mass and it exerts convective hydrodynamic pressure on tank wall and base. For representing these two masses and in order to include the effect of their hydrodynamic pressure in analysis, spring mass model is adopted for ground- supported tanks and two-mass model for Intze type water tanks.

- In spring mass model convective mass (m_c) is attached to the tank wall by the spring having stiffness (K_c), where for Intze tanks two-mass model is considered, which consists of two degrees of freedom system. Spring mass model can also be applied on Intze tanks, but two-mass model idealization is closer to reality. The two-mass model is shown in Fig 1(a). where, m_i , m_c , K_c , h_i , h_c , h_s , etc. are the parameters of spring mass model and charts as well as empirical formulae are given for finding their values. The parameters of this model depend on geometry of the tank and its flexibility. For Intze tanks, if the shape is other than circular or rectangular, then the values of spring mass parameters can be obtained by considering an equivalent circular tank having same capacity with diameter equal to that of diameter at top level of liquid in original tank. The two-mass model was first proposed by G. M. Housner (1963) and is being commonly used in most of the international codes. The response of the two degree of freedom system can be obtained by elementary structural Dynamics. However, for most of Intze tanks it is observed that both the time periods are well separated. Hence, the two mass idealizations can be treated as two uncoupled single degree of freedom system as shown in Fig.1 (b). The stiffness (K_s) is lateral stiffness of staging. The mass (m_s) is the structural mass and shall comprise of mass of tank container and one-third mass of staging as staging will acts like a lateral spring. Mass of container comprises of roof slab, container wall, gallery if any, floor slab, floor beams, ring beam, circular girder, and domes if provided. Finite element software Staad Pro v8i is used to find out stiffness of the model. Computer program has been prepared for seismic analysis using the MS-Excel according to IS 1893 (part 2):2014. Formulae and values for various parameters are taken from IS1893(part 2):2014. Each model is analyzed for tank empty condition, tank partially filled condition and tank full condition.

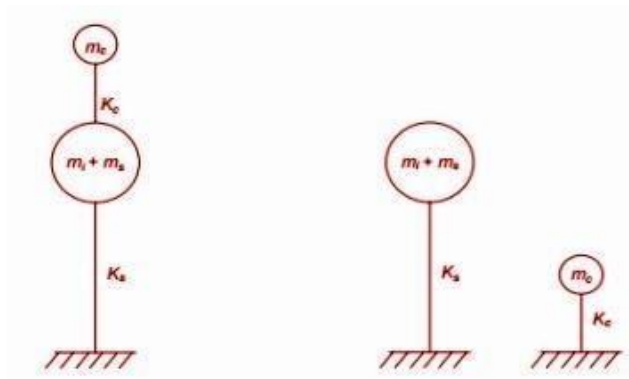

Two-mass idealization of Intze tank

Sr. No.	Parameter	Value
1	Size of column	600 X 600 mm
2	Size of bracing	300 X 600 mm
3	Top dome thickness	120 mm
4	Top ring beam	230 X 300 mm
5	Side wall thickness	150 mm
6	Bottom ring beam	450 X 300 mm
7	Bottom dome	200 mm
8	Circular ring beam	600 X 1200 mm
9	Diameter of Bottom Dome	13.865 m
10	Diameter of tank	20 m

General Dimensions

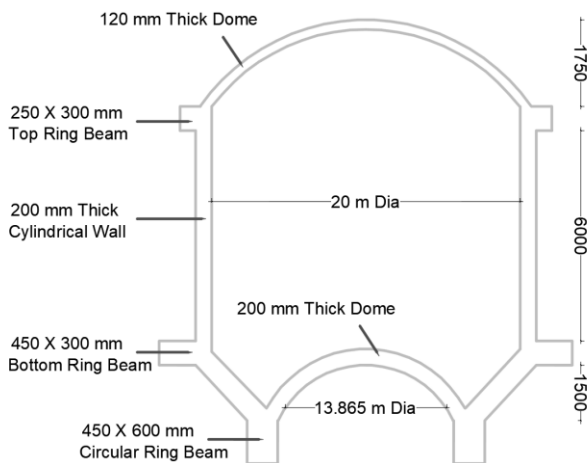

Container Dimensions

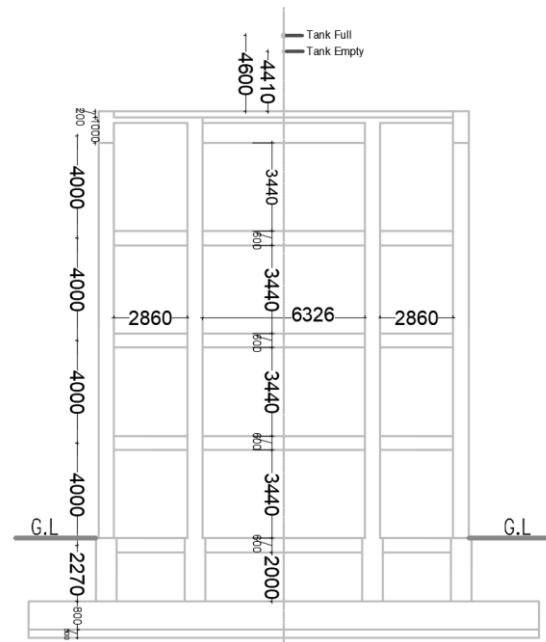

Staging Dimensions

Radius of Top Dome (R)	$[(r^2/\text{dome height}) + \text{dome height}]/2$	30.4308 m	
Radius of Bottom Dome (r)	$[(r^2/\text{dome height}) + \text{dome height}]/2$	17.85175 m	
Selfweight calculation of Members			
1 Top Dome	$2\pi R * \text{Thickness of Top Dome} * \text{Dome height} * 25$	$2 * 3.14 * 30.43 * 1.69 * 0.12 * 25$	968.879 KN
2 Top Ring Beam	$[\pi D]^2 * \text{size of top ring beam} * 25$	$3.14 * (20 - 0.4 + 0.23)^2 * 0.23 * 0.3 * 25$	107.4092 KN
3 Cylindrical Wall	$[\pi D] * h * 25$	$3.14 * 20 * 0.2 * 6 * 25$	1884 KN
4 Bottom Dome	$2\pi r * \text{Thickness of Bottom Dome} * \text{dome height} * 25$	$2 * 3.14 * 17.85 * 1.4 * 0.2 * 25$	784.686 KN
5 Bottom Ring Beam	$[\pi D]^2 * \text{size of Bottom ring beam} * 25$	$3.14 * (20 - 0.4 + 0.45)^2 * 0.45 * 0.3 * 25$	212.4799 KN
6 Conical Dome	$[\pi * (D+d)]/2 * Lc * \text{dome thickness} * 25$	$3.14 * 16.933 * 2.17 * 0.25 * 25$	721.113 KN
TOTAL			4678.567 KN

Weight of Water

Capacity of Tank	1800000 litres	1800 m ³
Density of Water	9.81 KN/m ³	
Weight of Water	$1800 * 9.81$	17658 KN

Self Weight Calculation

1	Total Mass of Water	Weight	m	17,65,800	kg	2.1
		Volume		1,766	m ³	
2	Inner Diameter of Tank at Top	D		20.000	m	definition, P-6
3	Equivalent Height of tank = $V / (\pi D^2/4) =$	h		5.621	m	Cl.4.2.3, P-10
4	Ratio D / h	D/h		3.558		
		0.866 D/h		3.081		
	Ratio h / D	h/D		0.281		< 0.75
		3.68 h/D		1.034		
5	IMPULSIVE MASS :	m_i				
a	$m_i/m = (0.23 \tanh(3.68 h/D) / (h/D)) =$	m_i / m		0.323		Table C-1
	Hence value of impulsive mass $m_i =$	m_i		5,70,632	kg	
b	Ratio- Height of impulsive mass to Total Ht. $h_i/h = 0.375$ for $h/D \leq 0.75$ $= 0.5 - 0.09375^2 D/h$ for $h/D > 0.75$ (h_i is not used in computing period of vibration, T)	h_i / h		0.375		
		h_i		2.108	m	
c	(h_i^* is used for checking overturning moment) $h_i^*/h = (0.866D/h) / (2 \tanh(0.866D/h)) - 0.125$ $= 0.45$ for $h/D > 1.33$ (min.value=0.45)	h_i^* / h		1.422		
	Hence value of $h_i^* =$	h_i^*		7.994	m	
6	CONVECTIVE MASS :					
a	$m_c/m = 0.23 * \tanh(3.68h/D) / (h/D) -$	m_c / m		0.635		Table C-1
	Hence Value of Convective Mass $m_c =$	m_c		11,20,833	kg	
	Check Sum of Convective Mass & Impulsive Mass =			16,91,465	= 95.79 % of total mass	
b	Ratio of ht. of Convective Mass to Total ht., $h_c/h = 1 / [\cosh(3.68h/D) - 1] / [3.68h/D \sinh(3.68h/D)]$	h_c / h		0.540		Table C-1
	Value of $h_c =$	h_c		3.04	m	
c	(h_c^* is used for checking overturning moment) $h_c^*/h = 1 / [\cosh(3.68h/D) - 2.01] / [3.68h/D \sinh(3.68h/D)]$	h_c^* / h		1.335		Table C-1
	Hence value of $h_c^* =$	h_c^*		7.504	m	
d	Stiffness of Convective Mass $K_c = 0.836(mg/h) \tanh(2(3.68h/D))$	K_c		1,00,282	kg/cm	Table C-1
e	Coef. for Time Period, C_c $C_c = 2\pi / \sqrt{3.68 \tanh(3.68h/D)}$	C_c		3.719		C4.3.2.2

Impulsive and Convective Mass Calculation

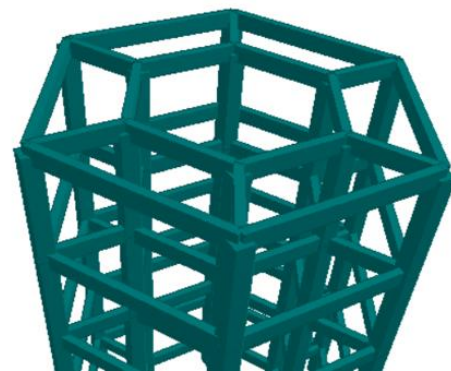
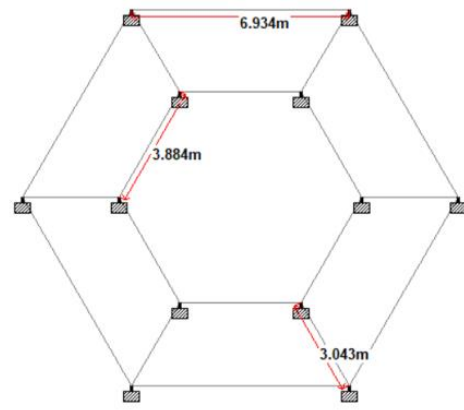

Hexagonal tube Pattern

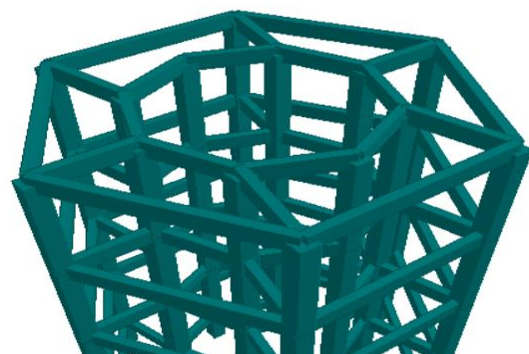
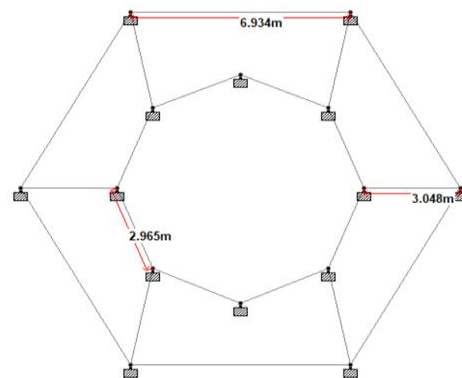

Octagonal Tube Pattern

CG of empty container			
	Weight(KN)	height	
1 Top Dome	968.879	9.22	8933.06438
2 Top Ring Beam	107.409	7.95	853.90155
3 Cylindrical Wall	1884	4.8	9043.2
4 Bottom Dome	784.686	0.92	721.91112
5 Bottom Ring Beam	212.48	1.65	350.532
6 Conical Dome	721.11	1	721.11
	4678.56		20623.7791
	CG OF EMPTY CONTAINER		4.40814298
			4.41 m
CG of full container			
	Weight(KN)	height	
1 Top Dome	968.879	9.22	8933.06438
2 Top Ring Beam	107.409	7.95	853.90155
3 Cylindrical Wall	1884	4.8	9043.2
4 Bottom Dome	784.686	0.92	721.91112
5 Bottom Ring Beam	212.48	1.65	350.532
6 Conical Dome	721.11	1	721.11
7 Water	17658	4.65	82109.7
	22336.6		102733.479
	CG OF FULL CONTAINER		4.5933412
			4.6 m

CG of Empty and Full Container

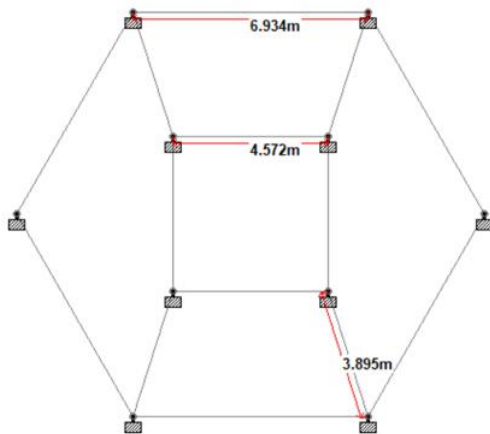

II For Octagonal Tube in Tube			
1 Column load	No	Weight	Total
	14	141.3	1978.2 KN
2 Brace	size	no	length
i	300X600	30	6.93
ii	300X600	40	2.97
iii	300X600	20	3.34
iv	300X600	10	3.048
			TOTAL(KN)
			935.55
			534.6
			300.6
			137.16
			1907.91 KN
			3886.11 KN
2.4 SEISMIC LOADS :			
2.4.1 SEISMIC MASS at C.G. of Container :			
		Tank Empty	Tank FULL
1 Self Wt.		468	468 tonnes
2 Water			1,766 tonnes
3 STAGING	Total Load	191	
	Seismic Load = W/3	64	64
		532	2,298 tonnes

Octagonal Pattern Load Calculation

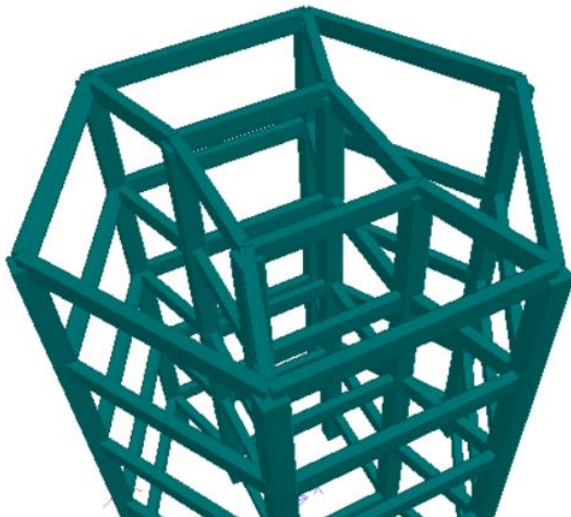

Square tube Pattern

III For Square Tube in Tube			
1 Column load	No	Weight	Total
	10	141.3	1413 KN
2 Brace	size	no	length
i	300X600	30	6.93
ii	300X600	20	4.572
iii	300X600	20	3.9
			TOTAL(KN)
			935.55
			411.48
			351
			1698.03 KN
			3111.03 KN
2.4 SEISMIC LOADS :			
2.4.1 SEISMIC MASS at C.G. of Container :			
		Tank Empty	Tank FULL
1 Self Wt.		468	468 tonnes
2 Water			1,766 tonnes
3 STAGING	Total Load	170	
	Seismic Load = W/3	57	57
		525	2,291 tonnes

Square Pattern load Calculation

I For Hexagonal Tube in Tube			
1 Column load	No	Weight	Total
	12	141.3	1695.6 KN
2 Brace	size	no	length
i	300X600	30	6.93
ii	300X600	30	3.88
iii	300X600	30	3.048
			TOTAL(KN)
			935.55
			523.8
			411.48
			1870.83 KN
			3566.43 KN
2.4 SEISMIC LOADS :			
2.4.1 SEISMIC MASS at C.G. of Container :			
		Tank Empty	Tank FULL
1 Self Wt.		468	468 tonnes
2 Water			1,766 tonnes
3 STAGING	Total Load	187	
	Seismic Load = W/3	62	62
		530	2,296 tonnes

Hexagonal Pattern load Calculation

3. Results:

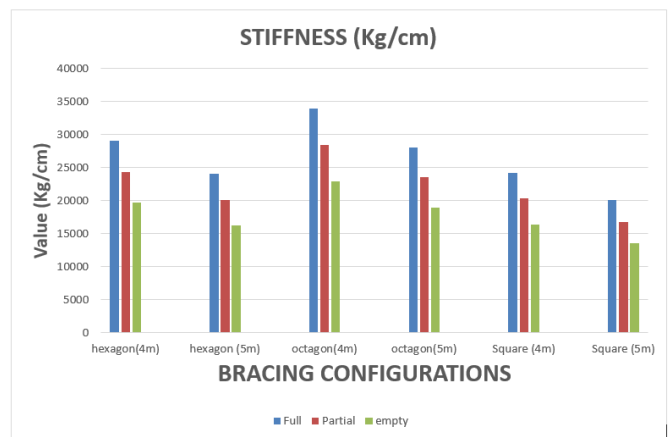

Stiffness of Staging

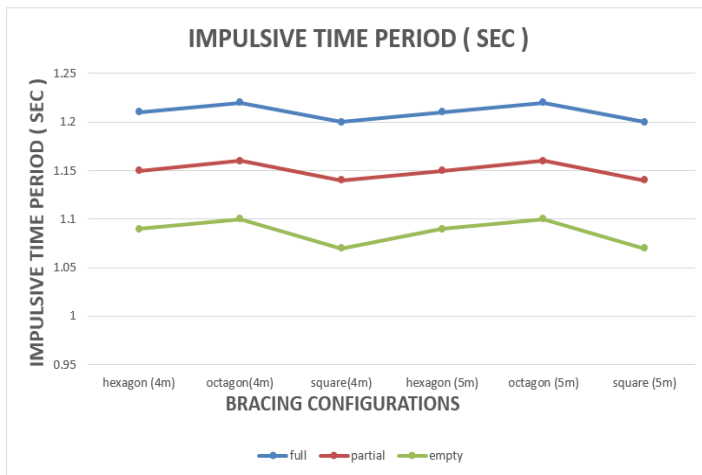

Impulsive Time Period

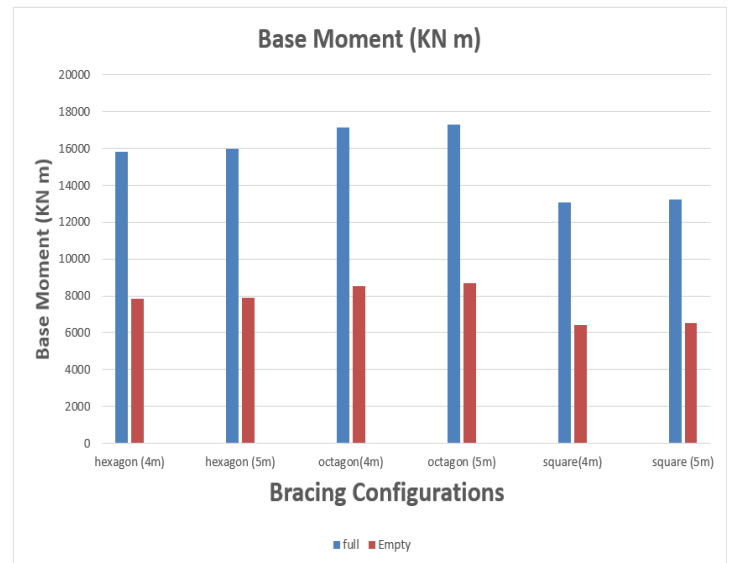

Base Moment

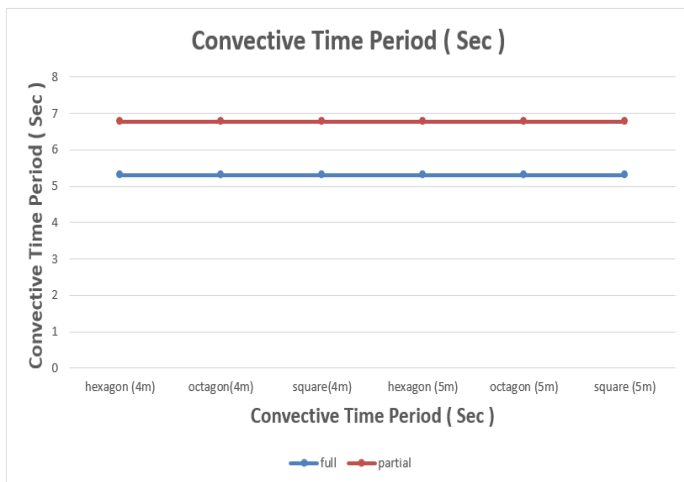

Convective Time Period

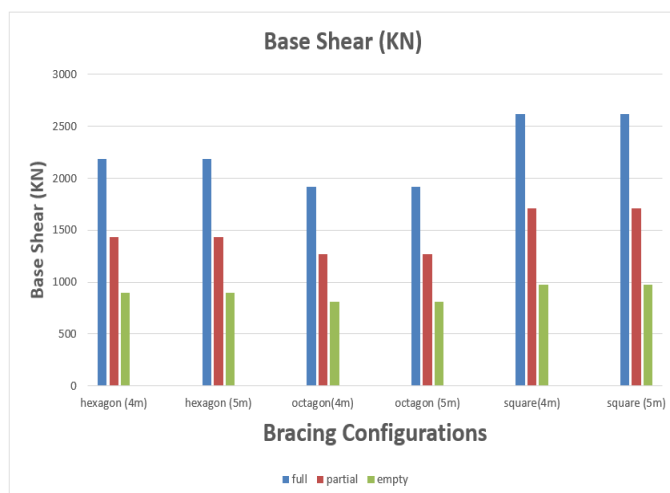

Base Shear

4. CONCLUSIONS:

- The Stiffness of fully filled tank with Octagonal bracing Configuration with staging height 4m is maximum and 16.8% more as compared to horizontal bracing configuration (Base Configuration) and as of empty tank with Square bracing Configuration for 5m staging height is minimum and 31.1% less as compared to Base Configurations.
- Maximum Impulsive Time Period is of Octagonal Bracing Configuration.
- The natural time period in impulsive mode for partially filled condition is lower than that of tank in full condition. This indicates that partially filled condition is more critical.
- The type of bracing configurations does not affect the natural time period in convective mode for a given depth of water, as the h/D is constant for a particular depth of water.

Future Scope:

- Study on composite water tank behaviour under earthquake analysis can be carried out.
- Study on different shape of water tank behavior under earthquake analysis can be carried out.
- Study on different h/D ratio for water tank can be carried out.
- Study on cost optimization can be carried out for different tanks.
- Study on different vertical pattern of staging behaviour under earthquake analysis can be carried out.

REFERENCES

- [1] S.C. Dutta, S.K. Jain, C.V.R. Murty., "Alternate Tank Staging Configuration With Reduced Torsional Vulnerability", Elsevier -Soil Dynamics and Earthquake Engineering.
- [2] Suchita Hirde, Nagesh D. Walase, "Seismic Performance Of Elevated Storage Reservoir With Different Bracing Configurations", International Journal of Computer & Mathematical.
- [3] G.P.Deshmukh, Ankush.S.Patekhede, "Analysis Of Elevated Water Storage Structure Using Different Staging", International Journal of Research in Engineering and Technology.
- [4] Santosh Rathod, M. B. Ishwaragol "Analysis Of Overhead Water Tank With Different Staging Height And Base Width", International Research Journal of Engineering and Technology.
- [5] M.K. Shrimali, R.S. Jangid "Earthquake Response Of Isolated Elevated Liquid Storage Steel Tanks", Journal of Constructional Steel Research.
- [6] IS: 1893-2014 (Part-II, Liquid Retaining Tanks) Criteria for Earthquake Resistant Design of Structures, Bureau of Indian standards, New Delhi, India.
- [7] IITK-GSDMA Guidelines For Seismic Design Of Liquid Storage Tanks (Provisions with Commentry) by S.K.Jain, O. R Jaiswal , Indian Institute of Technology Kanpur, Kanpur.