

A Detail Review on Vibratory Bowl Feeder

Mohit¹, Mr. Naresh Kumar Sharma²

PG Scholar¹, Assistant Professor²

Department of Mechanical Engineering

SRM University, Delhi-NCR, Sonipat, Haryana – 131029, India.

Abstract: With the technological advancements and human development, a shift towards automation has addressed a sea change. Automation not only reduces human efforts and time required in the production process but also improves the quality of the product with maximum efficiency. Automation in other words has given the people a way to work in a much faster, accurate and precise manner, such that the product is obtained undamaged in its stated quality. The way assembly lines operate in industries across the globe, has seen a major upheaval as a result of unprecedented industrial growth and technological advancements. Vibratory feeders are self-sustained machines that use vibrations to feed materials to other machines. They are suitable for feeding small components in a directed path from a randomly distributed and unaligned bulk of components. The objective of this paper is to analyze and test the performance of a modified path when 2 set of industrial bottle caps having same height but different diameters are fed in the vibratory bowl feeder. The feed rate was studied experimentally by varying the input parameters such as part population, frequency of vibration and diameter of the parts. A research to find an optimum range of operation of the feeder was finally done by manual and graphical calculations.

Key Words: Automation, Vibratory Bowl feeder, Feed rate

INTRODUCTION

Vibratory bowl feeders are common devices used in automatic assembly system to feed individual components or parts on industrial production lines for assembly. They are used when randomly sorted bulk package of small components must be fed into another machine one by one, in correct oriented direction for the purpose of further machining. Due to its versatility and simplicity it is most popular kind of used feeder in the industries. In VBF bowl size may vary from 100mm to 500mm. When the magnet receives power, vibrations produced. This vibrations produce a motion that allows parts to proceed up in the spiral ramp on the inside curved surface of the bowl. Parts that are not properly oriented are dumped back into the bowl. Parts do get shaken tremendously before they reach the top. Orientation of parts relies on its shape. Vibratory bowl feeders are not flexible as ramp within the bowl feeder are specially designed for each part. The track length, width and depth are carefully chosen to suit each component shape and size. Electromagnet used in vibratory bowl feeder has two parts: one is fixed to the base and other to the bowl moves with the bowl. Compared with other devices vibratory bowl feeders consume low energy and cause little pollution. They are wear resistant and do not influence the quality of the product they handle. There is smooth movement of parts and components.

Others types of feeding system are given below:

- **Bowl feeders:** consists of a bowl top with a spiral track inside the bowl. The component parts are delivered from the bottom of the bowl feeder up the track into the top of the feeder as the bowl vibrates. The parts are then positioned in the proper position.
- **Centrifugal feeders:** also referred as 'rotary feeders', have a conical central driven rotor surrounded by a circular bowl wall. The feeder separate component parts utilizing rotary force and the parts revolve with high speed and are pulled to the outside of the bowl.
- **Step feeders:** Key features of step feeder are that it operates quietly and without vibration.
- **Linear feeders:** Horizontal conveying of components. Used to handle irregular supplies of parts from upstream equipment. Special application: Multi-track design.
- **Carpet feeders:** Enable gentle handling of orientated components from bulk to escapement devices.

Vibratory feeders are utilized by all industries including:

- The automotive
- Electronic
- Cosmetic
- Food
- Packaging

It also serves other industries such as glass, foundry, steel, construction, recycling, pulp and paper, and plastics. Vibratory feeders offer a cost-effective alternative to manual labour, saving manufacturer’s time and labour costs. Several factors must be considered when selecting a parts feeder, including the industry, application, material properties and product volume.

Literature Review

[1]. “Design and development of vibratory bowl feeder”. (2017) by – Rohit Bhagat et al – In this paper, the writer wants to provide a conveyor path for two types of washer’s i.e. metal and plastic washer. This can be achieved by the development and manufacture of orientation tool. [2]. “Performance analysis of a vibratory bowl feeder” (2017) by – Tushar Deshmukh – By changing different parameters performance analysis of vibratory bowl feeder is carried out. As feed rate affect a lot on performance of vibratory bowl feeder. So performance analysis of feed rate with respect to different parameters like size, frequency, part population and voltage is done. [3]. “Graphical analysis of bottle caps feeding in a vibratory bowl feeder” (2017) by – Manik Kapoor et al – In this paper graphical analysis is done by taking parameters like part population, frequency and diameter of caps into consideration. The result shows that feed rate increases with increase in part population. [4]. “Graphical analysis of a vibratory bowl feeder for clip shaped components”. (2017) by – Ujjwal Jindal et al – graphical analysis is done for clip shaped component with different parameters like frequency, part population and length of clips. Results show that with increase in frequency there was an increase in feed rate and after certain frequency, the feed rate levelled off. [5]. “Vibratory bowl feeder: A graphical analysis of its performance for feeding nails.” (2018) by – Ishika Tiwari et al – The objective of this paper is to provide graphical analysis for feeding nails by taking different parameters like part size, part population and frequency into consideration. Results show that part size and part population has negative effect on feed rate whereas frequency has positive effect on feed rate.

Vibratory Bowl Feeder

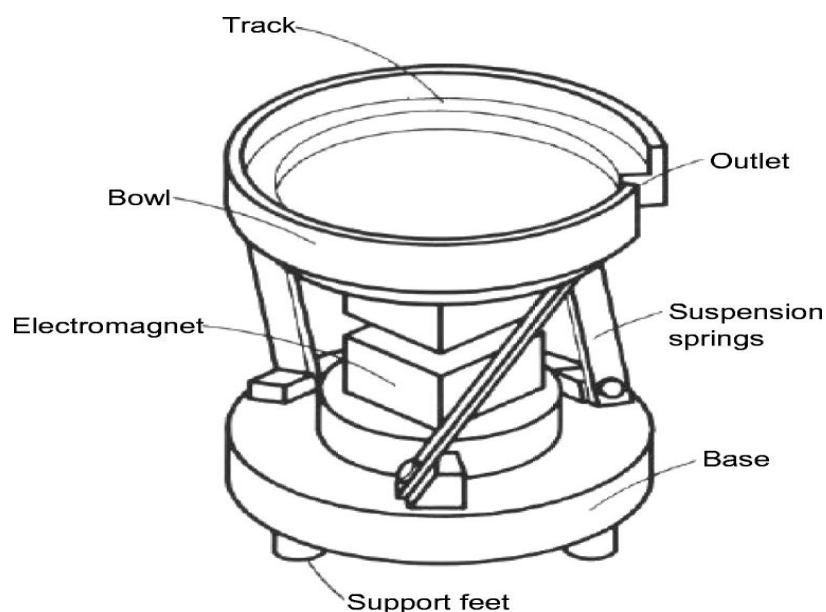

Figure shows a vibratory bowl feeder. The typical bowl feeder includes base, bowl, and track and control system. Bulk parts are fed into the bowl and are oriented and discharged to our specification for our processing application. Vibratory bowl feeders can also be custom designed for specific parts. Before feeding the parts to the bowl, parts size, weight and material properties must be taken into account. Special coatings and linings can be done on the surface of the bowl feeder which help in proper orientating and feeding of the parts.

Experimental Setup

The path of the vibratory feeder was altered in order to align to the requirements:

- A path using a galvanized iron sheet was designed and fabricated in such a way that the desired type of component was only allowed to pass.
- The rejecter constructed in the fabricated path was designed in such a way that it contained small slots followed by semi-circular metal extrusions of less than half the diameter of the fed caps.
- A sheet metal stopper was inducted in the fabricated path of the feeder in order to ensure that only one component was fed to at a time.
- Precautions measures to avoid jamming of the components were adopted by constructing the fabricated path wide enough for proper passing of the components.



Performance Parameters

The parts used for the analysis were flat-base bottle caps. Although the performance of the feeder depends upon various factors like:

Part population, material of caps, width & inclination of the path, frequency of operation and diameter of caps, experimentation has been carried out on the following three variable parameters:

- **Part population:** It is defined as the number of parts in the bowl of the vibratory feeder at any given time.
- **Frequency:** Frequency of operation is that frequency at which the vibratory bowl feeder operates to feed the parts in the bowl at the given time.

Table

Bowl	Material	Suitable for
Cylindrical bowl	Al, steel, stainless steel	Continuous transport of components and for handling small parts
Conical bowl	Al, stainless steel	For larger loads and for sharp edged components
Stepped bowl	Al, stainless steel	For larger components

Feeder Speed

Following are the parameters to determine the feeder speed:

- F = frequency (vibrations / cycles per minute)
- A = amplitude (length per cycle)
- K = constant (factor = 1.3)

Generally, 60Hz power, part feeder normally vibrates at a frequency of either 3600 or 7200 vibrations cycles per minute. The 7200 vibrations / minute parts feeder is generally used when handlings parts are difficult to orient.

Conclusion

Vibratory bowl feeder has been overviewed. Its various parts are studied. Design and development has been done. Performance analysis has been done. Graphical representation of various parts with different parameters has been done.

References

1. Rohit Bhagat , Nirmal Bondre , Sanket Chaskar , Nikhil Bhoyat , B.S. Mashalkar , Design and Development of Vibratory Bowl Feeder: International Research Journal of Engineering and Technology (IRJET): Volume: 04 Issue: 4 April 2017
2. Tushar Deshmukh , Performance Analysis of a Vibratory Bowl Feeder: International Journal of Current Engineering and Technology: Volume 7 , No.5 (Sept/Oct 2017)
3. Manik Kapoor , Tivish Allabadi , Umang Singhal , Pradeep Khanna , Graphical Analysis of Bottle Caps Feeding in a Vibratory Bowl Feeder: International Journal of Innovative Science , Engineering and Technology: volume 4 Issue 12 , December 2017
4. Ujjwal Jindal , Shrey Jain , Piyush , Pradeep Khanna , Graphical Analysis of a Vibratory Bowl Feeder for Clip shaped Components: International Journal of Innovative Science , Engineering and Technology: volume 4 Issue 2 , February 2017
5. Ishika Tiwari , Laksha , Pradeep Khanna , Vibratory Bowl Feeder: A Graphical Analysis of its Performance for Feeding Nails: International Research Journal of Engineering and Technology (IRJET): Volume: 05 Issue: 6 June 2018