

IoT based Health and Safety System for Manual Scavengers and Miners

Deepa R

Assistant Professor, Chaitanya Bharathi Institute of Technology (A), Hyderabad, Telangana, India

Abstract - Despite ban on manual scavenging i.e. manually cleaning, carrying, disposing or handling human excreta from dry latrines and sewers in India since 1993, the activity still continues and laborers are deployed for cleaning of sewers, septic tanks etc manually. These laborers work in a very severe and hazardous environment and their lives are highly vulnerable to illness, safety issues and even death. Statistically more than 1300 lives have been lost in India over the past couple of years with around 250 lives lost in Tamilnadu state alone. It is highly imperative that a comprehensive health and safety monitoring system is implemented to ensure that no more lives are lost in the field of manual scanning. Internet of Things (IoT) is the new revolution in the field of mining, oil and gas industries as well as medical sciences etc. IoT exploits wireless networking of devices, big data and artificial intelligence technology to deliver highly efficient and transparent safety systems with high degree of accuracy and control. IoT devices retrieve the data related to worker's health and safety and wirelessly transmit the data to control centres for effective monitoring and control. The control centres collect the data on worker's health parameters and environmental parameters and alert the worker and authorities about potential danger. This reduces number of accidents and life loss as well as lowers corporate liability and insurance cost. The proposed IoT based Health and Safety System collects and transmits various health / environment sensor data to the control room wirelessly (point to point communication) and in parallel it transmits the data to the ThingSpeak IOT Cloud for monitoring and reporting. On the other side the control room receives the data from the sensors and sends SMS alert to the designated officials who exercise control of the whole activity, through GSM shield.

Key Words: IoT, Wireless Health and Safety System, NDNbT

1. INTRODUCTION

All industries in world are transforming today as a result of technological advancements and simultaneously the industrial control and safety systems are evolving from isolated standalone systems to ubiquitous systems which are inter communicable and exchange large amount of data between themselves.

Internet of Things (IoT) is impacting the whole business spectrum in an exponential way by interconnecting all the objects and devices involved in a particular activity or business. IoT is a cumulative group of anyone, anything,

anytime, anyplace, any service and any network which can interact with each other.

Any IoT application comprises of four layers, viz. sensors, data aggregator, processor and cloud as depicted in Fig. 1. The sensor layer includes all sensor nodes, radio frequency identification (RFID) tags etc. The data generated by the sensor layer are collected in the second layer by the data aggregators. The data aggregators could also act as sink nodes for sensor networks or RFID readers or act as intermediate local storage. The data aggregators forward their data to the third layer called the processing layer for further processing. After the data processing is completed, the data is uploaded to the fourth layer called cloud layer to provide ubiquitous connectivity for data exchange with anything, anywhere, at any time.

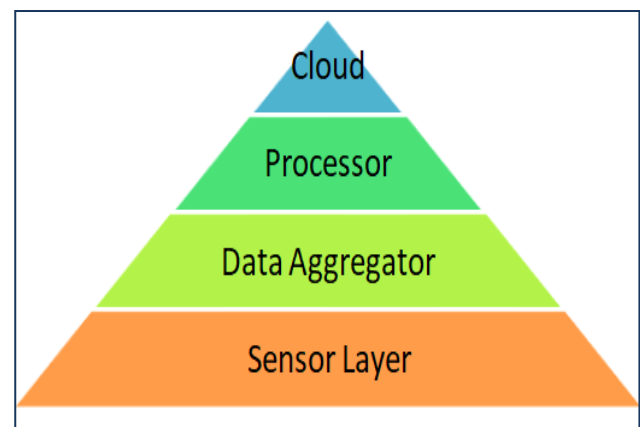

Fig -1: Layered Architecture of IoT

All IoT applications consist of numerous M2M (Machine 2 Machine) nodes with advanced connectivity of devices, systems, and services. Hence, automation and monitoring is feasible at every level. IoT proves to be the most appropriate solution for a wide spectrum of industrial applications such as traffic management, construction of smart cities, recycling of waste, manufacturing processes in industries, healthcare and safety monitoring, supply chain management as well as security surveillance.

Healthcare and safety monitoring is the most nascent field where IoT based applications are highly sought after since they increase the quality of life as well as enrich the user's experience by reducing device down time through remote provisioning and optimum replenishing of spares as well as by reducing the operational cost.

In the field of mining and manual scavenging the work environment is very hazardous due to presence of harmful gases like Hydrogen Sulphide (H₂S), Carbon Monoxide (CO) and Methane (CH₄). These gases can cause severe

irritation of eyes and respiratory track, nervousness, dizziness, nausea, head ache and drowsiness. At high concentration it leads to unconsciousness and can also be fatal. Moreover, methane is highly inflammable and extremely dangerous.

Feasibility of using a wireless health and safety monitoring system for miners and manual scavengers etc. who work in hazardous work environment is being proposed in this paper. The proposed system can prove to be a life savior in these fields. As a prototype study, few health and environment parameters are captured, transmitted and monitored. Also alert escalation messages are sent using GSM technology to the authorities who are controlling the activity.

2. PROPOSED SYSTEM

Efficient sewage system is a very critical system for any nation for protection of health of people and also the environment. The health and hygiene of people is a very crucial factor in deciding the growth and development of a nation and its citizens. Sewage services have started in most of the nations to ensure that the environment is protected and the population is healthy. Till recent times the sewage cleaning services was being done manually. Despite the imposed ban on manual scavenging and sewage cleaning in India since 1993, the task is still being carried out manually to some extent and statistics clearly say that death of sewage workers is on the rise due to improper knowledge of the workers and non adherence to basic safety precautions during execution of work. Closed sewers and drainages generate large amount of very poisonous gases because of anaerobic conditions prevailing in the location. Large amount of poisonous gases are generated inside the sewers and septic tanks viz. Hydrogen Sulphide, Carbon Monoxide and Methane which are proven to be very dangerous for human beings. Excessive levels of these gases cause various ill effects such as irritation, nausea, dizziness, unconsciousness and even death in some cases.

To address this immediate requirement of reducing mortality in the workers who are engaged with sewage services, an IOT based Health and Safety System is being proposed in this paper which monitors certain crucial health parameters of the worker and also certain parameter of the working environment. The system transmits these recorded parameters to the control authority for continuous recording and monitoring. It also generates alert messages in case any parameter crosses the fixed limit so that necessary corrective action can be initiated and the workers are protected from dangerous repercussions. The proposed system monitors heart beat rate and body temperature of the worker to ascertain his stability as well as monitors the level of harmful gas inside the working environment so that the vulnerability of the worker is continuously monitored.

3. SYSTEM ARCHITECTURE

Figure 2 and 3 illustrates the Proposed Architecture and main components of the system.

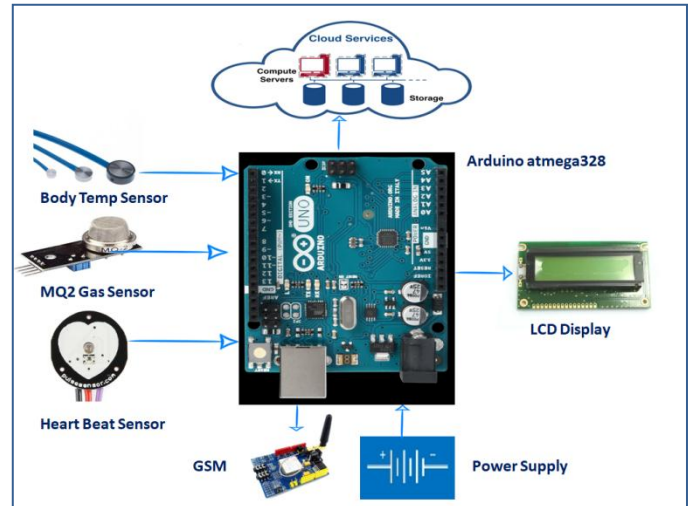

Fig -2: Proposed System

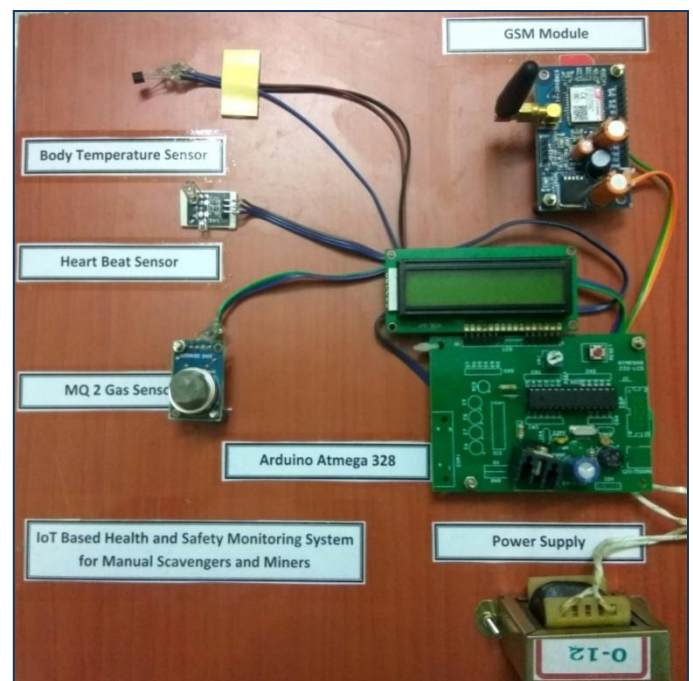

Fig -3: Assembly of components

3.1 Arduino Atmega328

We have used Arduino Uno which is a microcontroller board based on atmega328 datasheet. The board can be powered through USB port or suitable external power supply. The board also consists of 32 Kb memory, 2 Kb of SRAM and 1 Kb of EEPROM. The board has multiple communication capabilities to interact effectively with computer and other microcontrollers. Arduino software or

In-Circuit Serial Programming (ICSP) can be used to program the board appropriately.

3.2 Heart Beat Sensor

Psycho-physiological stimulus is measured by a Heart Beat Sensor gives an understanding on the functioning of the heart. The sensor consists of a bright red LED and a light detector. When blood is pumped through the vessels it makes our finger slightly opaque and thus altering the amount of light reaching from the LED to the detector. The signal received varies with every pulse. This signal is converted into an electrical pulse, amplified and triggered which gives an output of +5V logic level signal. The output signal is also directed by a LED display which blinks on each heartbeat rate.

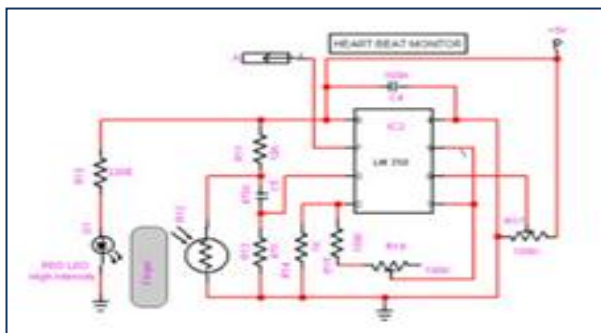

Fig -4: Heart Beat Sensor Circuit Diagram

3.3 Body Temperature Sensor

The body temperature (in degree Celsius) is converted to proportional electrical signal by integrated circuit sensor LM35.

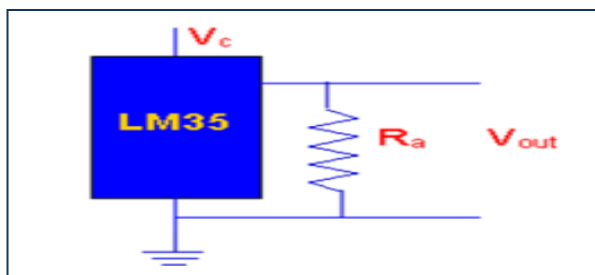

Fig -5: Body Temperature Sensor Circuit Diagram

3.4 MQ2 Gas Sensor

MQ2 Gas Sensor can presence of gases like Hydrogen, LPG, Methane, CO, Alcohol, Smoke or Propane. The sensor has very high sensitivity and fast response time and it can instantaneously detect presence of even infinitesimal amount of harmful gases. The sensitivity of the sensor can also be adjusted as per field requirement.

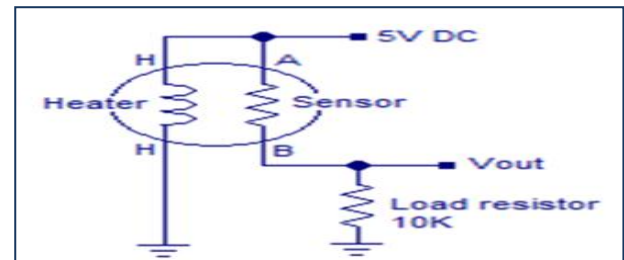

Fig -6: MQ2 Gas Sensor Circuit Diagram

3.5 GSM Module

GSM technology has made it possible to use a single telephone number around the world and also it provides excellent speech quality and wide range of other secondary services along with various security features which makes it useful in the field of remote sensing and monitoring.

GSM Modem has the capability establishing wireless communication of a computer with the GSM network. It works with a SIM (Subscriber Identity Module) card like a mobile phone for communication. Similarly each device can be identified using their IMEI (International Mobile Equipment Identity) number. A GSM module contained a GSM modem along with interfaces like RS-232 (Serial Port), USB for communication; so that the module can be interfaced with any microprocessor / controller based system as well as any computer. The module has an in built power supply circuit which is activated by a suitable adaptor. Most of the GSM modems work on TTL logic. But when they use RS232 standards, compatibility issue arises with any other TTL plat form devices. This problem is eliminated by using MAX232.

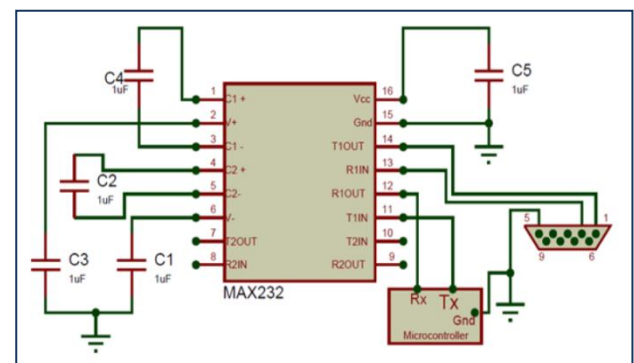

Fig -7: GSM Module

3.6 LCD Display

The LCD Display of Arduino is a serial monitor which allows simple text data to be sent to and from the board. It is a crystal based display which does not emit light directly but has a property of light modulation. These displays are used where you want to display any arbitrary images and low information fixed images with low information content. They work on the same principle as 7 segment

displays, except that they are made up of small pixels in high numbers.

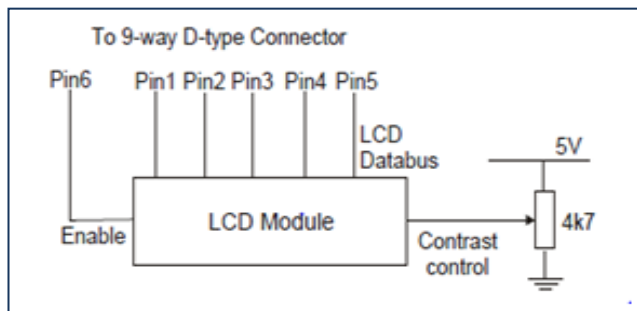

Fig -8: LCD Module

3.7 Power Supply

The power supply consists of 230V AC connected to a step down transformer, followed by a full wave diode rectifier. The rectified voltage is filtered using a capacitor filter and the dc voltage with certain amount of ripples is regulated using an IC regulator. This regulated voltage remains constant even in when there is fluctuation in the input voltage or load connected.

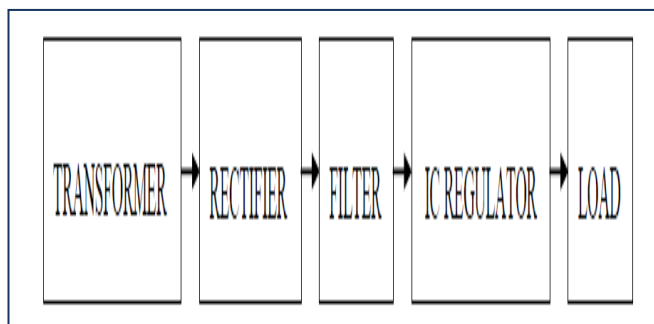

Fig -9: Power Supply

3.8 UART

Universal Asynchronous Receiver/Transmitter (UART) is an intermediary circuit that implements serial communication between parallel and serial interfaces.

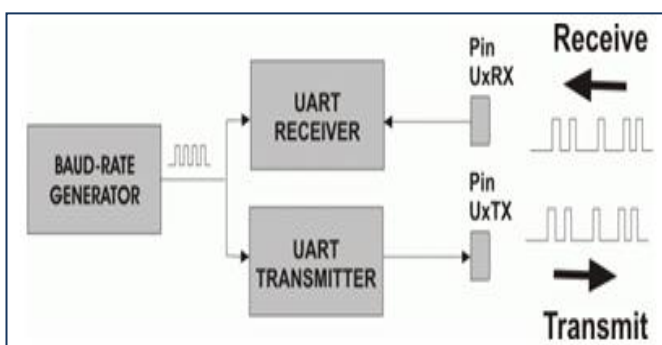

Fig -10: UART

4. IMPLEMENTATION

4.1 Transmitter Section

The transmitter section comprises of heart beat sensor, body temperature sensor and MQ2 Sensor. All these Sensors are nothing but transducers which convert non electrical quantity into electrical quantity because in nature all are non-electrical in form. Sometime sensors are analog or digital in nature, if the sensors are analog in nature the values produced from the sensor vary with respect to time on the other hand digital sensors produce only two values either 0 or 1, it is always better to use the with analog in nature to get perfect values.

These values are fed to the heart of our proposed system i.e. Arduino Uno microcontroller board embedded with atmega328 microcontroller. The main function of this board is to accept the values from various sensors and process the values to upload it to IOT cloud i.e. ThingSpeak and transmit the same values wirelessly using Xbee shield. The communication between Arduino and Xbee is asynchronous in nature because there is no clock signal or start bits used to synchronize the communication. The Xbee board at the transmitter is configured as API coordinator mode so that it creates a network and accepts the data from routers of same network (Private area network) each time the Xbee receives 8 bits at the baud rate of 9600. The Xbee boards, before connecting to the Arduino Uno platform, must be configured with the software's i.e. X-CTU or cool term to make it as coordinator sensor with analog in nature to get perfect values.

Once the Arduino connects to the internet, the data from the three sensors is fed to the ThingSpeak IOT cloud. In order to connect to the ThingSpeak the user must create the user accounts and user channels with all the credentials required. Once the channel is created, we can feed data from 8 sensors to one ThingSpeak channel and the data can be accessed anywhere in the world. The transmission flow chart starts from Start and ends at updating the sensed values to the ThingSpeak cloud.

4.2 Receiver Section

The Receiver Section comprises of Arduino Uno platform, Xbee board and GSM module. The End Devices communicate to the router, the router communicates to between the devices and the data is sent to coordinator of the network. The Xbee board receives data from all routers in the network and is processed in Arduino Uno. Finally SMS is sent to the authorized officials through GSM Module, so that they can assess the situation and take appropriate action immediately. The receiver section starts from Start and ends by sending SMS to the authorized person or enrolled person.

5. EXPERIMENTED RESULTS

The graphical representation of the results in The IoT Cloud Fig 11a and 11b shows the timestamp of the Cloud creation and the private channel settings, API keys and Data Import and Export.

The Channel Settings consists of Channel Name and Channel Description and the Fields i.e. the field names for the sensors and Metadata information about the channel. It includes JSON, XML or CSV data. We can also link any external website that contains information about our channel by specifying the URL.

Name	Created	Updated At
 IOT based Health and Safety Monitoring System	2018-03-23	2018-04-08 20:11

Private Public Settings Sharing API Keys Data Import / Export

Fig -11a: Cloud Creation

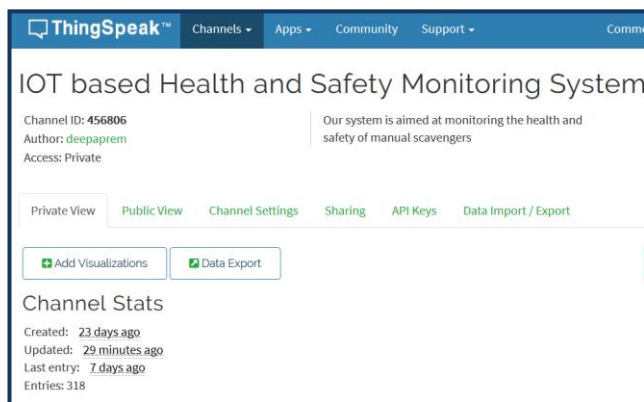

Channel ID: 456806
 Author: deepaprem
 Access: Private

Our system is aimed at monitoring the health and safety of manual scavengers

Private View | Public View | Channel Settings | Sharing | API Keys | Data Import / Export

Add Visualizations Data Export

Channel Stats
 Created: 23 days ago
 Updated: 29 minutes ago
 Last entry: 7 days ago
 Entries: 318

Fig -11b: Private Channel Settings

API Key: API key enable us to write data to the channel and also read data from the private channel. Our system has a private channel, we can use the “Read API Keys” to allow other people to view our private channel.

Example:

GET https://api.thingspeak.com/update?api_key=M8G5SM4EDTFZ6B66&field1=0

Chart 1 shows Heart Beat rate of the worker measured against date and time stamp and is plotted continuously. Lower rate of heart beat is immediately escalated by means of message through the GSM Module to the

supervising team for their immediate intervention and action.

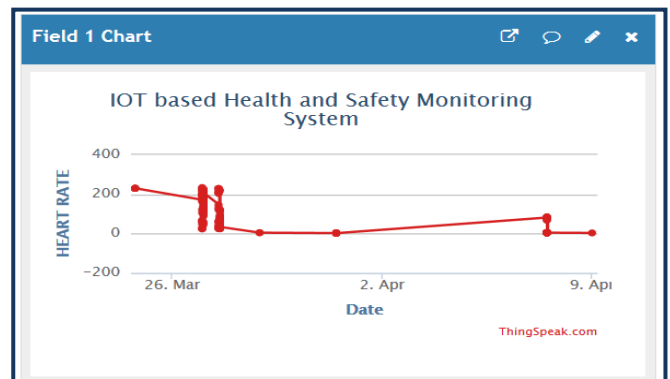

Chart -1: Heart Beat Monitoring

Chart 2 shows Body Temperature of the worker continuously monitored against date and time stamp. Body temperature above fixed standard is immediately escalated by means of SMS through the GSM Module to the supervising team for their immediate intervention and action.

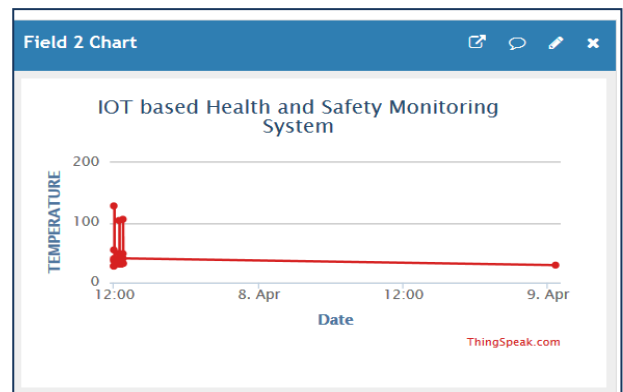

Chart -2: Body Temperature Monitoring

Chart 3 shows the gases present in working environment monitored continuously and increase of specified harmful gases above acceptable level is escalated by means of SMS through GSM Module to the supervising team for their immediate intervention and action. Here '0' indicates No harmful gas detection and '100' indicates harmful gases present.

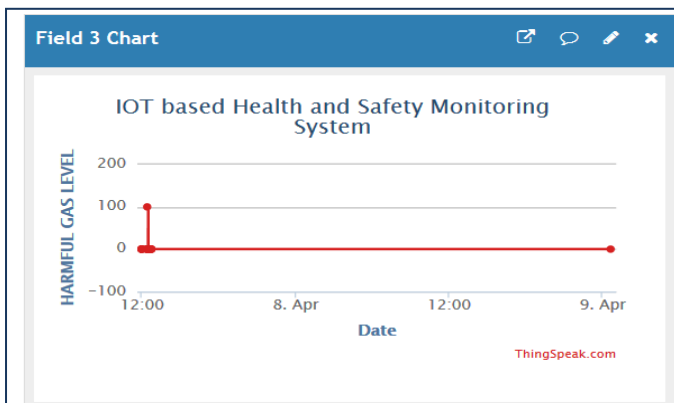

Chart -3: Harmful Gas Monitoring

Fig 12 shows the exporting of data recorded during the event for analysis. Data can be exported in various formats like XML, Jason or XML and used for further analysis and research.

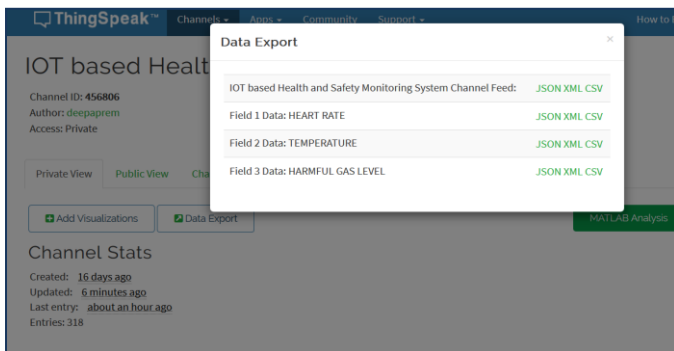

Fig -12: Data Sheet for analysis

4. MOBILE APPLICATION

The above mentioned data can also be viewed through mobile application by configuring the channel settings through API Keys. Chart 4a and 4b shows screenshots of mobile application and various data collected by the system, which can be viewed in the mobile application.



Chart -4a: Mobile Application Screenshot 1



Chart -4b: Mobile Application Screenshot 2

4. CONCLUSIONS

Manual Scavengers are exposed to harmful environment; our proposed system will help sense and collect the heart beat rate, body temperature and any harmful gases if any and send the information to the cloud. Authorized person with valid username and password will be able to see the data collected and analyze the same. In case if the threshold values are crossed in these cases, immediately the authorized person will be alerted through SMS. In this project the results are displayed in cloud and the same thing can be viewed in mobile app after configuring the channel settings using the API keys. In future the same application can be extended by using the MATLAB using new algorithms and provide the Mat lab code for analyzing data and writing it into ThingSpeak channel. At present the entire implementation is based on the IP architecture, so in future the same can be implemented using NDNofT, name based Networking Architecture for the Internet Of Things to overcome the challenges faced in present IP based IoT architecture.

REFERENCES

- A. Gerd Kortuem and Fahim Kowsar(2010, Feb). Smart Objects as Building Blocks for Internet of Things IEEE Internet Computing. Available: <https://publications.computer.org/internet-computing/>
- B. Li Da Xu and Wu He Shancang Li(2014,Novemeber). Intenet of Things in Industries: A Survey IEEE Transactions on Industrial Informatics, Vol 10, No. 4. Available: <https://www.ieee.org/publications/rights/index.html>
- C. Andrea Zanella , Nicola Bui, Angella Castellani (2014,feb)Internet of Things For Smart Cities IEEE Internet Of Things Journal, Available: <http://www.smartsantander.eu/>
- D. Lu Tan, Neng Wang (2010) Future Internet :The Internet Of Things
- E. S.M. Riazul Islam, Daehan Kwak, MD.Humaun Kabir,Mahmud Hossain and Kyung-Sup Kwak (2015,April),The internet Of Things for Healthcare :A Comprehensive Survey. IEEE Access :The Journal for rapid open access publishing. Available:

http://www.ieee.org/publications_standards/publications/rights/index.html

- F. Amar Abane, Mehammed Daoui, Samia Bouzefrane, Paul Muhlethaler (2017, August) Future Generation Computer Systems Available: <https://doi.org/10.1016/j.future.2017.09.053>
- G. Deepa R, K Suresh Joseph(2018,January)NDNoT:Name Based Routing in IoT Networks-A Survey,International Journal For Advanced Research in Computer Science and Technology. Available:ISSN:2347-8466
- H. Cristane Bude and Andreas Kervefors Bergstrand (2015, June) Internet Of Things Exploring and Securing a Future Concept.

BIOGRAPHIES



Deepa R received B.E degree from Vishweshwariah Technological University, Belgaum and M.Tech in Network and Internet Engineering from Pondicherry University. she is presently working as Assistant professor in the department of IT at CBIT(A),Gandipet.Her area of Interest includes research in IoT, Machine Learning, Sensor Networks and Data Science