

IoT based Advanced Underground Coal Mine Environment Detection and Auto Alert System for Coal Mine Workers using Blynk Application

Tirunahari Sri Sharan¹, Hitesh Dammu², Mahendarkar Karthik³, Sai Akhil M⁴

¹⁻⁴UG Student, Dept of Mechatronics Engineering, Mahatma Gandhi Institute of Technology, Telangana, India

Abstract – Coal Mining is a dangerous and potentially lethal job. Workers in coal mines face many environment related problems such as high temperature, humidity, release of harmful gases to name a few. As a means of reducing the intensity of the problem, our present work focuses on sensing these environmental parameters from different locations in the mines and sends alert to the mine control room operator who uses a Blynk Application whenever there seems to be a dangerous situation.

Key Words: Temperature Sensor, Humidity Sensor, Gas Sensor, APR9600 Voice Module, Buzzer, Blynk Application.

1. INTRODUCTION

Coal Mining is inherently dangerous with zero margin for error even under the best conditions. Even a small lapse in safety can be catastrophic. The principal airborne hazards in the mining industry include several types of particulates, naturally occurring gases, engine exhaust and some chemical vapours; the principal physical hazards are noise, segmental vibration, heat, changes in barometric pressure and ionizing radiation. The present paper is about the system which uses an IoT platform as a medium to transmit data. The system is implemented to monitor various parameters in the coal mines such as light detection, leakage of gas, temperature and humidity conditions and fire detection in the coal mine. These all sensors are together placed as a unit and sent into the coal mine and can be monitored by the operator using Blynk Application.

2. HARDWARE COMPONENTS

Arduino Nano: Arduino boards are widely used in robotics, embedded systems and electronic projects where automation is an essential part of the system. Arduino Nano is a small, compatible, flexible and breadboard friendly Microcontroller board, developed by Arduino.cc in Italy, based on ATmega328p (Arduino Nano V_{3.x})/ATmega168(Arduino Nano V_{3.x}). It comes with an operating voltage of 5V, however, the input voltage can vary from 7 to 12V. Arduino Nano Pinout contains 14 Digital pins, 8 Analog pins, 2 Reset pins and 6 Power pins. Each of these Digital and Analog pins are assigned with multiple functions but their main function is to be configured as input or output. The Nano board consists of a mini-USB port. This port is used for both programming and serial monitoring.

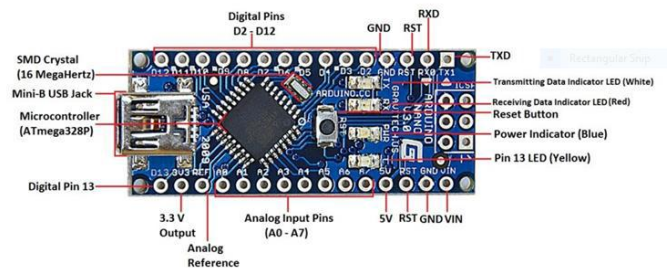

Fig 1: Arduino Nano Board

LM35 Temperature Sensor: LM35 is a precision Integrated circuit temperature sensor whose output voltage varies based on the temperature around it. It is a small and cheap IC which can be used to measure temperature anywhere between -55°C to 150°C. It can be easily interfaced with any Microcontroller that has ADC function or any development platform like Arduino.

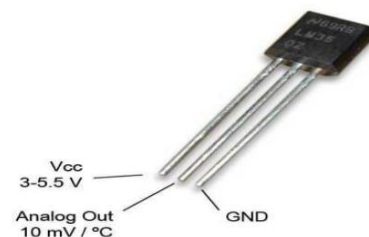

Fig 2: LM35 Temperature Sensor

Humidity Sensor: A Humidity Sensor, also called as a hygrometer, measures and regularly reports the relative humidity in the air. A humidity sensor senses relative humidity, this means that it measures both air temperature and moisture. Relative Humidity, expressed as a percent, is the ratio of actual moisture in the air to the highest amount of moisture air at that temperature can hold. The warmer the air is, the more moisture it can hold, so relative humidity changes with fluctuations in temperature.



Fig 3: Humidity Sensor

MQ3 Gas Sensor: This system uses a MQ3 Gas Sensor. It is useful for gas leakage detection (in home and industry). It is suitable for detecting Alcohol, Benzene, CH₄, Hexane, LPG, CO. Due to its high sensitivity and fast response time, measurements can be taken as soon as possible. The output voltage from the Gas sensor increases when the concentration of gas increases. The sensitivity of the sensor can be adjusted by using the potentiometer. It also has a stable and long life.



Fig 4: MQ3 Gas Sensor

APR9600 Voice Module: APR9600 is a low-cost high performance sound record or replay IC incorporating flash analogue storage technique. Recorded sound is retained even after the power supply is removed from the module. The replayed sound exhibits high quality with a low noise level.



Fig 5: APR9600 Voice Module

LM 293D Motor Driver IC: It is a popular 16-pin Motor Driver IC. As the name suggests it is mainly used to drive motors. A single LM293D IC is capable of running two DC motors.



Fig 6: LM 293 Motor Driver

ESP8266 Wi-Fi Module: The ESP8266 Wi-Fi Module is a self-contained SOC TCP/IP protocol stack that can give any microcontroller access to a Wi-Fi network. The ESP8266 is capable of either hosting an application or off loading all Wi-Fi networking functions from another application processor. ESP8266 on board processing and storage capabilities allow it to be integrated with the sensors and other application specific devices through its GPIOs with

minimal development up-front and minimal loading during run time. With its high degree of on-chip integration, which includes the antenna switch blaun, power management converters, it requires external circuitry and entire solution, including front-end module, is designed to occupy minimal PCB area.



Fig 6: ESP8266 Wi-Fi Module

3. INTERNET OF THINGS

The Internet of Things (IoT) is the inter working of physical devices, vehicles (also referred to as “connected devices” and “smart devices”), buildings and other items embedded with electronics, software, sensors, actuators and network connectivity that enable these objects to collect and exchange data. The IoT allows objects to be sensed and/or controlled remotely across existing network infrastructure, creating opportunities for more direct integration of the physical world into computer-based systems and resulting in improved efficiency, accuracy and economic benefit in addition to reduced human intervention.

4. BLYNK APPLICATION

Blynk Application is designed for the Internet of Things. It can control hardware remotely, it can display sensor data, it can store data, visualize it and useful for many other user requirements.

- **Blynk App:** It allows us to create amazing interfaces for projects using various widgets we provide.
- **Blynk Server:** It is responsible for all the communications between smartphone and the hardware. It is open source and can be easily handle thousands of devices and can even be launched on Raspberry Pi.
- **Blynk Libraries:** Available for all popular hardware platforms and enable communication with the server and process all the incoming and outgoing commands.



Fig 7: Blynk App showing the required data

5. BLOCK DIAGRAM

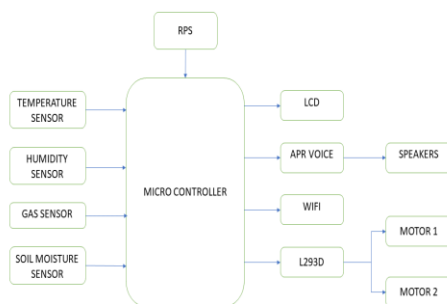

6. WORKING

A Gas sensor, Temperature Sensor, Humidity Sensor and Water sensor, interfaced to an Arduino board observe the respective parameters when the system is sent into the mine as a bot. The bot is driven by LM293D Motor Driver which drives the two motors fixed to the bot. The bot can be controlled by the user using Blynk Application. When any of the respective value reaches its peril, it alerts the user in the Blynk Application.

7. ADVANTAGES

- This system successfully automates the current coal mine safety system and replaces wired communication.
- It will greatly improve the performance and efficiency of data transmission of the coal mine safety system and reduce the costs of extending the system.
- The application of IoT can realize the real-time monitoring of working system. Existing networks are slow and heavily rely on manual labour. Use of IoT can enhance the whole performance of the existing networks.
- The loss of human life can be avoided significantly as this system assesses the situation inside the mine without the need of a human inside the mine.

8. CONCLUSIONS

- This paper mainly focuses on the system successfully automates the current coal mine safety system and replaces wired communication.
- With this implementation of wireless communication between mines and ground level, better security and working environments are made possible for miners. This system allows better chances of preventing disasters from occurring and for quicker response by the authorities in case of disaster.
- The components used in this system are really compact and cost a small amount in terms of size as well as money.
- This system can help in saving lives of workers by giving handy information, beforehand.

REFERENCES

- [1] E.K Stanek, "Mine Electro technology Research: The Past 17 Years", IEEE transactions on industry applications, vol. 24[5], pp 818-19, 1988.
- [2] S.Weij, L. Li-li, "Multi-parameter Monitoring system for Coal Mine based on Wireless Sensor Network Technology", Proc. International IEEE conference on Industrial Mechatronics and Automation, pp 225-227, 2009.
- [3] S.Jin-Jing, G. Heng-wei, S.Yu-jun, "Research on Transceiver System of WSN Based on V-MIMO Underground Coal Mines", Proc. International Conference on Communications and Mobile Computing, pp 374-378, 2010.
- [4] Dong "Coal Mine Safety Monitoring System Based on Zigbee and GPRS", Applied Mechanics and Material Volume 422, 2013.
- [5] LiHui "Design of Monitoring system for Coal mine safety based on Wireless sensor Networks", 2008 International Conference on Mechatronic and Embedded systems and Applications(ASME).