

INTELLIGENT HOME AUTOMATION PROGRAM

Sudhanshu Jha¹, Vetrivendan L.²

¹Student, Dept. of Computer Science and Engineering, Galgotias University, Uttar Pradesh

²Professor, Dept. of Computer Science and Engineering, Galgotias University, Uttar Pradesh

Abstract - With the increase in consumption of energy and population, there is a huge need to conserve energy in every way possible. One of the key causes for energy depletion is the failure to reach and operate equipment from distant areas. It requires automated monitoring by wireless connectivity of all electrical or electronic equipment in homes or even remotely. Home automation system (HAS) automatically controls the household appliances such as lamp, fan, roof, AC, TV, Webcam etc. Wireless switches or smart phones are used in home automation network Desktop, mobile, or home to run the appliance. Different forms of home automation technologies have been introduced, such as Robotics, ZigBee, Bluetooth, ARM9, SMS and Android ADK. This paper provides different techniques used for Home automation system.

Key Words: Automation, Components, Characteristics, Types, Access Control

1. INTRODUCTION

Home automation system is used to control the home appliances remotely and there are many home automation technologies available. It helps the user to run and monitor all home appliances, or to connect several devices such as home protection system, lighting, access control system, air conditioning etc. when users are away from home. Smart living spaces are favored with home automation systems that not only provide ease, security and protection but also but also have energy-saving solutions. Demand for appliance management systems is increasingly growing day after day and appears to be a major industry phenomenon in the future.

This type of system mainly consists of following components Controller (It is hardware interface that communicates with user interface by controlling home services), Mode of communication (wired connections or Wireless) Electronic Devices (A bulb, an AC or a heater etc.) and User interface (Give orders to control System for example as a monitor, computer, or Phone)[1]. A wide variety of options are available for the home automation systems and they can be used to save energy as well as ease our way of living and it also gets evolved day by day.

Now we will discuss the characteristics and challenges of the home automation system which will give us an idea how it is being used to ease our job and how it saves energy and then we will further move on to the different types of Home Automation System.

2. HOME AUTOMATION

The Smart Home known as House Automation, using modern technologies to make domestic tasks more convenient, comfortable, safe and cost-effective. Home automation technology is evolving day by day becoming more sophisticated and more normal.

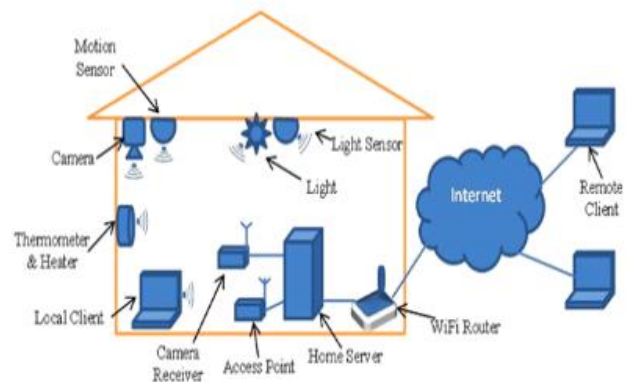

Fig.1: Architecture of Home Automation

2.1 Components of Home Automation

- 1) User interface: as a monitor, computer, or Phone, for example, that can give orders to control System.
- 2) Mode of transmission: wired connections (example Ethernet) or Wireless (radio waves, infrared, Bluetooth, GSM) etc.
- 3) Central Controller: It is hardware interface that communicates with user interface by controlling domestic services.
- 4) Electronic devices: a lamp, an AC or a heater, which is compatible with the transmission mode, and connected to the Central control system[2].

2.2 Characteristics of Home Automation

- 1) Reduced Installation Cost: No cabling needed, so installation costs are drastically reduced.
- 2) Internet Connectivity: The devices can be easily controlled with mobile phones using internet from anywhere in the globe.
- 3) Scalable: Network extension is commonly used nowadays as application for wireless networks.

4) Security: As built in security ensures integrity of smart home, devices can be easily added to make an integrated smart home [3].

3. HOME AUTOMATION TYPES

Different types of techniques were introduced for home automation systems such as Automation, ZigBee, Wi-Fi, SMS, and Internet, GSM, etc.

3.1 ZigBee Based Home Automation:

The wireless networking technology ZigBee can be extended to home automation. For this reason, the device is using PIC microcontroller and voice recognition. The voice commands are received from a mike. They are compared with and processed via a voice shop. The PIC microcontroller then transmits the commands to the receiver through ZigBee. The receiver device has another PIC microcontroller which will be able to process the signal. It uses relays to monitor the respective appliances. This device has the downside that ZigBee is a communication medium of limited range. While remote access from faraway places is hampered. The voice recognition module may also become unwieldy. This device has the additional feature that incorporates a smoke detector into the device. When smoke is sensed, it sends a message to the user's built-in mobile number.[4]

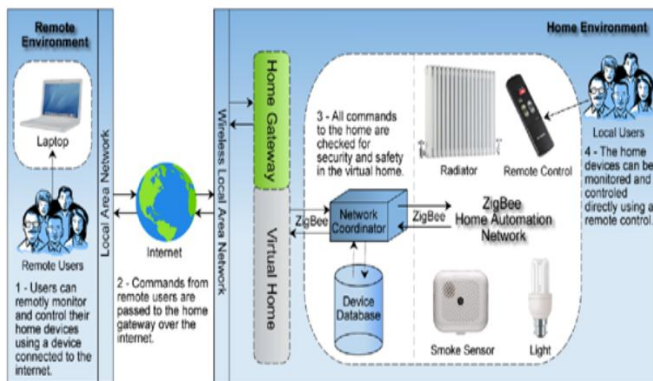

Fig. 2: Zigbee based Home Automation Architecture

3.2 GSM Based Home Automation:

Mahesh N. Jivani [5] developed GSM based home automation system using App-inventor for android mobile phone. For Android-based smart phones App Inventor is a latest visual programming platform for developing mobile applications. Figure2 shows system architecture, which contains the App Inventor (allows Android Apps to be built and programmed highlighted colourful building blocks easy to understand), Arduino IDE (Easy to write code and add it to the I / O board), GSM (Global Mobile Communications Service, originally Special Mobile Grouped).

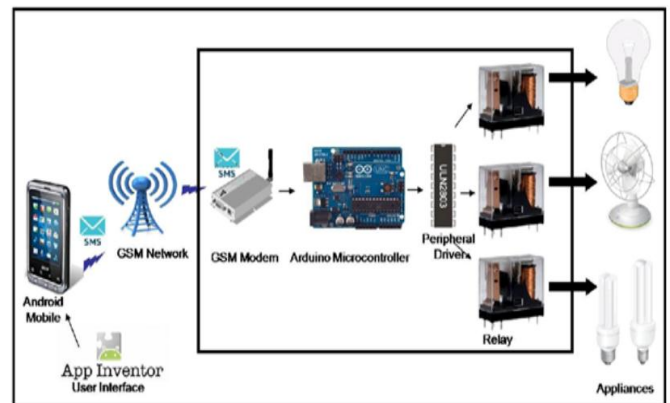

Fig. 3: GSM based Home Automation Architecture

3.3 Bluetooth Based Home Automation System

Bluetooth technology is considered as one of the best technologies to provide secure end to end communication between devices with no complexities. There are many types of Bluetooth modules in these various types of Bluetooth devices which are equipped for controlling various appliances. These modules are based on a number of requirements on which they perform the relevant operations. One of their requirements is that they work within a range of 45 m and at a frequency of 2.4GHz.Using this we build a home automation device that works using a Bluetooth technology. When designing a home automation system, we need to understand factors like this, so that the user will be able to connect to the Bluetooth module from any computer he wishes.

He should be able to move the host from one computer to another and that module should work accordingly.

On displaying any error or fault, it should have the ability to diagnose it and the system should start working immediately when an instruction is given to improve the nature of wireless technology. [3]

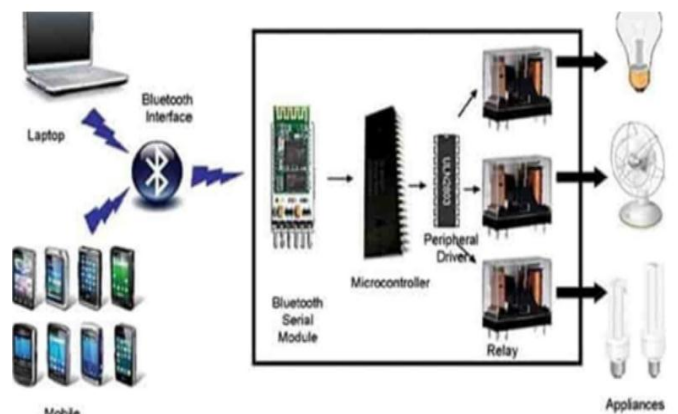

Fig. 4: Bluetooth based Home Automation Architecture

3.4 Cloud based Home Automation System

Device Cloud-based monitoring and control of home appliances [7]. Implementation and configuration of a home gateway for collecting information from home appliances and sending it to the cloud-based knowledge server for HDFS (Hadoop Distributed File System) storage, processing it using Map Reduce and using Remote user to create a monitoring function.

3.5 Internet-based Home Automation System

Internet or IP protocol-based communication in home automation systems is always a popular choice among researchers. The Internet is easily scalable, versatile when it comes to access and use, and is very common in today's world as a means of communication, so is the hardware and network required for access is readily available as well as it offers high bandwidth and very low communication cost, and devices can connect to and disconnect from the network easily. These are some of the features that make the Internet so appealing to researchers. The use of the Internet as a way of accessing and managing the home seems to be the next logical step for home automation systems. Through the point of view of an end user, it is simple, comfortable, inexpensive, and versatile to use the Internet to reach their home and it provides no challenge to learn with an added technology. User interface devices such as laptops, smart phones, PCs and tablets are readily accessible in the marketplace, and these devices are now part of daily life for people. So, incorporating home automation into these already popular user devices seems to be having the natural progression.

4. CONCLUSIONS

Home Automation System (HAS) is the latest age of the automated home system, with researchers using numerous techniques to achieve the best results. This study addressed numerous home automation systems such as Web-based, Bluetooth-based, Mobile, Zigbee-based, Cloud-based, Internet based systems. Home automation systems should be much smarter and more reliable in future. We would be able to extend it in near future to a scale of a level where it could be used in offices, colleges or factories.

Hence it can be concluded now that the required goals and objectives of a home automation system can be targeted by the above technologies.

REFERENCES

[1] Ms. Pawar Pallavi Tatyasaheb and Mr. B.E. Shinde, "A Review on Home Automation System Using Different Techniques", International Research Journal of Engineering and Technology (IRJET), Volume 03, Issue 06, June 2016, pp. 2996-3000.

- [2] Vaishnavi S. Gunge,' Smart Home Automation: A Literature Analysis', International Journal of Software Applications (0975 – 8887) National Seminar on Recent Data Mining Trends (RTDM 2016).
- [3] Divya Purohit1, Moumita Ghosh," Challenges and Types of Home Automation Systems", International Journal of Computer Science and Mobile Computing, Vol.6 Issue.4, April- 2017, pg. 369-375 M. Young, The Technical Writer's Handbook. Mill Valley, CA: University Science, 1989.
- [4] Vidhyalakshimi S , Naren T Kesh, Naveen Hariharan, Angel Deborah S," Home Automation Systems - A Study", International Journal of Computer Applications (0975 – 8887) Volume 116 – No. 11, April 2015.
- [5] Mahesh N. Jivani, "GSM Based Home Automation System Using Android Cell Phone Device Creator," International Journal of Advanced Research in Engineering for Electrical, Electronics and Instrumentation, Vol. 3, Issue 9, Sep 2014, pp. Ak. 12121-12128
- [6] Mr. Prafull R. Manjare1 , Mr. Swapnil W. Puranik2 , Mr. Ashok S. Wakhure3,"A Review On Different Techniques For Home Automation System", Vol-3 Issue-5 2017 IJARIIE(International Journal Of advance research and innovation ideas in education)-ISSN(O)-2395-4396.
- [7] YunCui, MyoungjinKim, YiGu, Jong-jinJung and HankuLee, "Home Appliance Management Framework for the Control of Digitized Devices Using Cloud Computing Technology in Ubiquitous Sensor Network Climate," Hindawi Publishing Company International Journal Of the 2014 volume of distributed sensor networks, Article ID 174097