

Smart Backpack

Mr. S. P. Jadhav¹, Kalpesh Malpure², Bhushan Kulkarni³, Harshal Joshi⁴, Jugalkishor Patil⁵

^{2,3,4,5} Student, Dept. of Information Technology, KBT College of Engineering, Maharashtra, India

¹Assistant Professor, Dept. of Information Technology, KBT College of Engineering, Maharashtra, India

Abstract - By using IoT components we are creating a backpack. Backpack is very necessary thing for students, employees and travelers. So we have an idea of developing a smart backpack which includes some features like GPS tracking as it will help parents to keep a track of kids going to school and tuition classes, we will also provide a solar panel which will charge a battery inside a backpack and that battery can be used to charge laptop and mobile anywhere anytime. This feature will provide mobility to the work of employees. The load sensor inside the backpack will calculate the weight of the backpack carry, we will also develop a mobile application which will be connected to all this sensor inside the backpack and all the data will be updated to the application. We are also going to provide the weather information by using location. The application will be user-friendly, there are many other smart bags available in the market but none of them is connected with an android application.

Key Words: Smart Backpack, GPS Module, Internet of Things, Load Cell module, IR Sensor, Arduino, Android.

1. INTRODUCTION

Probably in India now a days, students need to carry loads of books every day. The students stuff their bags with books and drag them for whole of the week, which result in the problem to their physical health like aching muscles, sore shoulders etc. By implementing a strategy, in which only those books which are required on that certain day could be brought to the school instead of horse-carting the entire syllabus. Also the kidnapping, molestation and sexual abuse of school-going children are increasing at an alarming rate. According to case study done by the source stated that around 25 thousand kids are lost and trafficked annually in India. There is a need of smart solution to this problem. So the parents might be able to know the whereabouts of their children. The motive behind the development of a smart backpack is that as a product it will be helpful for tracking the location of the backpack and also to calculate the weight of the backpack, it also holds solar panel which provide the power to the sensors

and charging mobile phone and laptop. In Our Project, main objective is to provide security and safety for school kids also to employees and it will also give mobility of work for the freelancer / corporate workers. Backpack has an Anti-Theft design which will provide the safety to contents in backpack. For security purpose tracking the location of backpack which will helpful if the backpack is stolen or forgotten. Mobile, Laptop charging using solar power supply which is optional according to the need of the user.

1.1 Problem Definition

To develop a smart backpack which will be helpful for tracking the location of the backpack and also to calculate the weight of the backpack, it also holds solar panel which provides the power to the sensors and charging mobile phone and laptop. In the proposed system, we have some features like missing items detection, calculate the weight of the backpack, GPS tracking and Power supply in which solar power supply is optional. In this we are using Load cell, IR sensors, GPS module, solar panel, Battery. All of this is integrated and connected to the ATmega 2560. The backpack integrated of multiple sensors, the IR sensors will give DI (Digital Input) to the ATmega 2560 and the NODE MCU will receive the DO (Digital Output) if the item is missing the Notification will be received on the LCD display as well as on the android device, the GPS sensor will send the location coordinates to receiver and transmitter send it to the ATmega 2560. The received data is sent to Node MCU which is connected to the Wi-Fi module. Power supply to the hardware will be provided by the battery and that battery will be charged by Solar Panel, external Mobile/Laptop. Load Cell will calculate the weight and using instrumentation amplifier IA the analog input will be received at ATmega 2560. All the inputs received at ATmega 2560 and outputs are shown at LCD 16X2.

2. RELATED WORK

There are many previous works related to this system. Some of them are mentioned here such as [1]

here the RFID tags were used for the detection of objects. In [2] where the focus was majorly on the tracking system, also in [3]. In [6] which provides the alert system for the antitheft protection. In [8] system was developed which was useful for charging mobile phones and other similar devices using solar power. In [9] it has various extra features like time table management, mobile charging, theft prevention, security by location tracking, etc. Panic button is one of the important features which will provide the safety of the user and make our life more easy and comfortable.

3. EXISTING SYSTEM

Solar Backpack are branded bags easily available in the market costing from 6000 to 24000 INR and they can charge all types of phone, Mp3 players, Laptop etc. They are water resistant and light weight, some bags with GPS tracking are also there in the market which costs around Rs. 4000. Smart Bag with Theft Prevention and Real Time Tracking is already implemented system that is a really helpful system for students and to their parents to know about where the child is in the real time.

4. PROPOSED SYSTEM

The proposed system is based on Internet of Things and android. Thus we are developing the embedded system, which consists of both hardware and software part. Architecture of smart backpack has ATmega 2560, Node MCU, Wi-Fi module, GPS, Battery, Solar Panel, Load Cell, IR Sensors, LCD 16x2. In this system the power supply is provided using the battery or solar power can also be used as it's an optional feature this power is used by various sensors especially ATmega 2560 receive the power and further it transmits it to other sensors. Initially, the bag has three different IR sensors in different columns which receive the signal by sensing an object and give the digital input "DI" to ATmega 2560, and the digital output is transmitted from ATmega 2560 to Node MCU there are three IR sensors so 3 digital input and three digital output transmission takes place. Load cell in the base of the bag calculates the weight and the calculated data is transferred as an analog input to ATmega and it further displays the calculated weight on the LCD display as well as on android application. Having GPS sensor inside the bag which transmits the coordinates to ATmega further received by Node MCU translate this data to

Wi-Fi module and Wi-Fi can be connected to any Android device and using the dedicated Android application all this data received by ATmega 2560 can be displayed on Android application which includes GPS live location, objects present or absent inside the bag, weight the bag carry and dynamic changes which are performed due to the data provided by sensors. The bag also has solar panels as its exterior design which provides the power supply to the battery to get charged and even the solar power supply can be directly provided to dedicated sensors, this power supply can also charge mobile phones, tablets, laptops and other similar devices. This feature mostly helps travellers and freelancers to keep their work on going as charging is always available in their bag.

4.1 Battery Efficiency and Optimisation

We have used a rechargeable 12V 1.3Ah lead acid battery. Battery backup of the backpack is up to 18 hours with full charge. We have added a power supply mechanism which converts the voltage according to the need of sensors. So it optimizes the battery usage. And also we have provided the solar panel which will supply the power to charge the battery to provide extra hours of battery life. Approximately 1-2 hours required to fully charge the battery with supplied adapter.

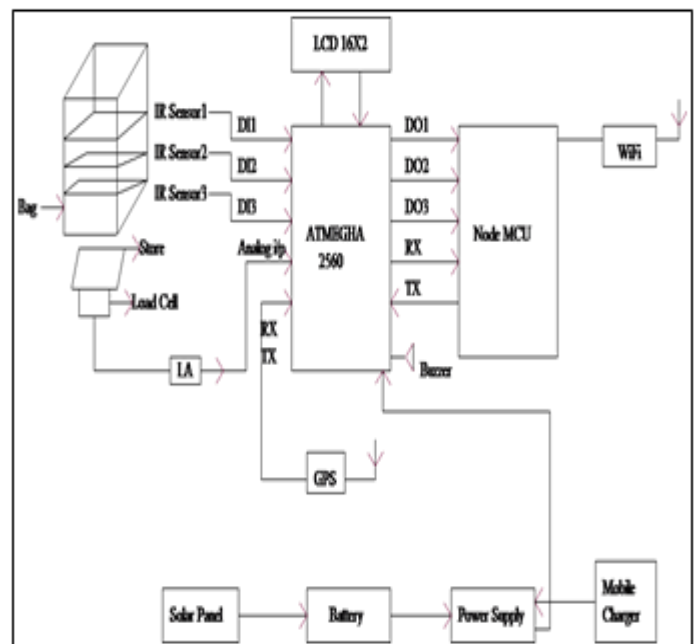

Fig-1 Architecture of Proposed System

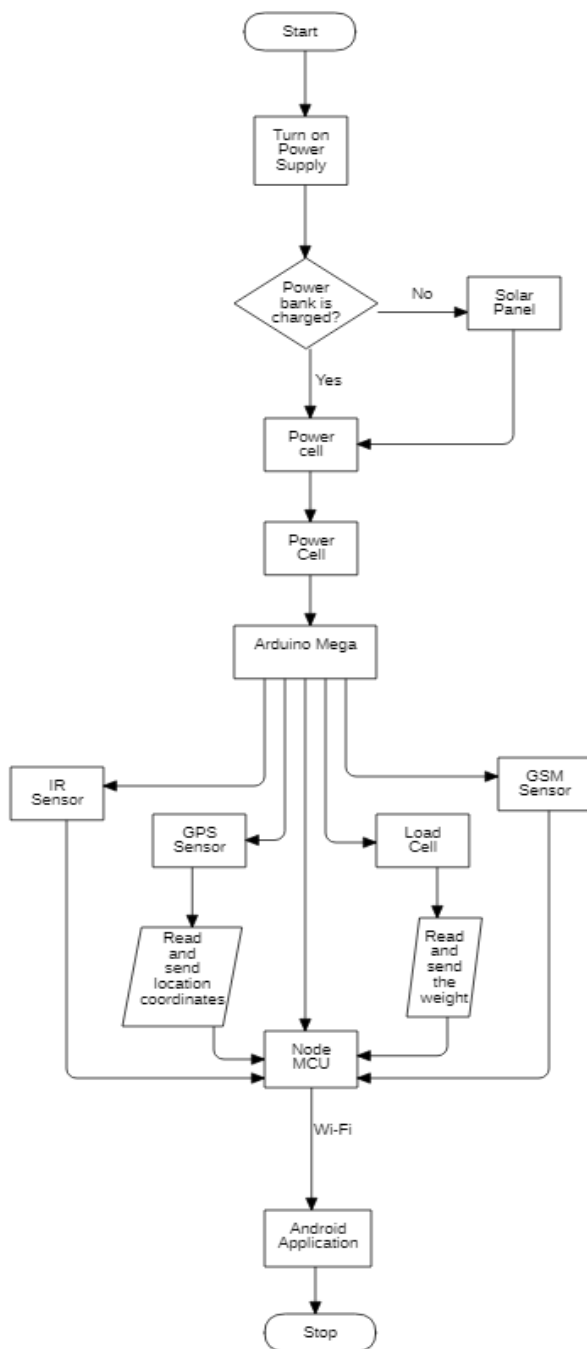

Chart -1: Flowchart of System

5. ADVANTAGES

1. Location Tracking.
2. Displays weight of backpack.
3. Gives missing item notification.
4. User friendly Android application.
5. Anti-Theft design

6. FUTURE SCOPE

Where we foresee the world growing and developing speedily, the complete package of smart backpack has a tremendous scope. When it comes to tracking the bearer's location, safety, charging the devices, luggage weight control, and handy access through android application, theft tracking etc., and this smart bag is all to fulfill these requirements. The future preferences lead to upcoming scope and competition to design and manufacture such smart bags in large numbers, also additional features can be added for performance and security.

7. CONCLUSIONS

This project is the combination of hardware, software and IoT technology. As the design of backpack is user-friendly people of any age group can use it according to their requirements. The most vital feature of this backpack is GPS tracking and also is powering the entire circuitry and charging of mobile phones through solar energy using the solar panel. This product will be useful for students, employee, etc. as it has features like Missing item notification and weight calculation. It is very helpful product which provide the mobility of work to the users, it is safe with GPS tracking. Using android application functionality can be controlled.

REFERENCES

- [1] P.G.Gayathri, K.Abhirami.M.E, T.Sivaranjani, "Pervasive Interaction Smart Bag Using RFID Technology", International Journal of Engineering and Innovative Technology (IJEIT) Volume 3, Issue 9, March 2014.
- [2] Muhamad Syazwan Rosdi and Nabihah Ahmad, "SMART HANDBAG SYSTEM WITH LOCATION TRACKING", 2016 Asian Research Publishing Network (ARP) VOL. 11, NO. 18, SEPTEMBER 2016 ISSN 1819-6608.
- [3] Shweta M, Tanvi P, Poonam S, Nilashree M, "Multipurpose Smart Bag", Procedia Computer Science 79 (2016) 77 – 84.
- [4] Athul P Anand, Deepesh Srivastava, Dushyant Sharma, Jyoti Rekha Dhal, Arun Kumar Singh, Mahendra Singh Meena, "Smart School Bag", DOI. 10.4010/2016.1467 ISSN 2321 3361 2016 IJESC
- [5] Mrs.Rasika Naik, Sanjana Muppudwar, Pallavi Chavan, Siddhi Medhekar, Pooja Chindarkar, "SMART BAG", February 2016, Volume 3, Issue 2 JETIR (ISSN-2349-5162).
- [6] Shubham Sarkar, Suvojit Manna, Subhadeep Datta, "Smart Bag Tracking and Alert System using RFID", 2017 International Conference on

Electrical, Electronics, Communication, Computer and Optimization Techniques (ICEECCOT).

- [7] Ankush Sutar, Tukaram Kocharekar, Piyush Mestry, Prathamesh Sawantdesai, Mrs. Suhasini S. Goilkar, "Smart Bag with Theft Prevention and Real Time Tracking", ISSN No: 2456-6470.
- [8] Vikas Varshney, Manish Nath Tiwari, Pranjal Jha, Deepak Gupta, "Solar Powered Smart Bag", Proceedings of the 12th INDIACom; INDIACom-2018; IEEE Conference ID: 42835 2018 5th International Conference on "Computing for Sustainable Global Development", 14th - 16th March, 2018.
- [9] Priti Shinde, Ankita Pathak, Manali Jage, Aniket Khade, Neha Rai, "Android Based Smart Bag", IJSRD - International Journal for Scientific Research Development— Vol. 6, Issue 01, 2018 — ISSN (online): 2321-0613.
- [10] Rakhi Varma, Pooja Pavshhe, Akshay Bhadane, Shrushti Pagare, "MULTI- FUNCTIONAL BAG MONITORING SYSTEM", Volume: 05 Issue: 12 — Dec 2018 p-ISSN: 2395-0072.