

# TRAFFIC DETECTION USING AUTOMATED MOVABLE ROAD DIVIDER AND TRANSMITTING DATA TO IOT

Dr.Ch. Pamuleti<sup>1</sup>, Abhiram Kurre<sup>2</sup>, Niharika Sunke<sup>3</sup>, Nikhitha Rudramu<sup>4</sup>

<sup>1</sup>Associate professor, Department of Electronics and Communication, Sreenidhi Institute of Science and Technology, Telangana, India

<sup>2,3,4</sup>B. Tech 4<sup>th</sup> year, Department of Electronics and Communication, Sreenidhi Institute of Science and Technology, Telangana, India

\*\*\*

**Abstract** - The main aim to make use of the roadway dividers are to mutually separate the traffic of incoming as well as the ongoing automobiles. Due to the growth in population, usage of vehicles in individual family are increasing. But still there is control in assets and this shows the large number of automobiles such as bikes, trucks and cars continuously running on the roads. In that instance the stable roadway dividers fix the amount of road lines on both the sides of the roadway. It invites the best use of assets which are available. In some of the metropolitan areas and cities the major crowded areas have the congestion which starts solely in one direction every mornings and evenings. In peak hours one side of the road is not utilized properly. It leads to the traffic jam and waste of time. So, we decided to setup an automated movable smart divider which shifts the direction of the lane where there is a traffic congestion. So, by this smart divider we can save our time and fuel. Based on the particular direction it can add one more lane. From proposed application below, the traffic coordination and the dependency is controlled. And this way we propose a smart system to setup with less, average and large density of the traffic and it could be recorded in the IOT server. This gives the more result for more traffic problems which are faced by the public.

**Key Words:** Automobiles, metropolitan areas, smart divider, traffic congestion, IOT server.

## 1. INTRODUCTION

The main problem faced by the dividers is the paths of the two sides of the road is equal. As there are constrained resources and there is enormous increase in the population, the vehicles used by the public is more and high increase of cars, trucks and autos on roads. Many people face the traffic problem everyday so that they should reach their respective destinations in time. Sometimes they could miss the important work which they could not attend in time. During the peak or busy hours one side of the road is unutilized and the

other is full of vehicles. This problem could be rectified using this automated system and the people can reach their destinations in time and lead a comfortable and safe journey. This shows that it makes the best use of the paths which could be accessible. According to the study made on the traffic detection the Western Express road located in Maharashtra was chosen which consists of ten-lane. This location of the western express road was chosen to have the information of the present situation of the traffic over the far distance travelling. This survey was taken for 13 hours. The data which was gathered from the study are passing of the vehicles at a certain point and the vehicles speed is taken. These outputs are given by the straight forward extraction giving data to the type of automobiles on that way and noting the type of automobiles over a span of time is taken. Reversed class speed there in particular slot in hours owing the little knowledge of the perfect problem of congestion.

## 2. LITERATURE SURVEY

The automobiles such as cars and trucks are increasing on the roads along with development of metropolitan cities over the world. Due to the misguidance of the roads they have been magnified and the structure is similar and it could not address the difference in congestion, road accidents that square measure taking the heavy form and the unpredictable travel time delays. Traffic jam is the major concern by the cities instead of taking the measures in reduction of traffic. This concept of movable road dividers was from the 90's, the reason was that there was tie up from that period. At that amount the machine used was Zipper machine which is employed to shift the road divider from one lane to the different lane.

It was absolutely introduced in earlier 90's and the first operating model of Zipper machine was bought by Hawaii department of transport in late 90's. This machine contains an inverted s shaped conveyer

channel that lifts the barrier section consideration nearly up-to 450kgs. 100feet length is the minimum length of the machine. The barrier segment is attached to the machine and whenever there is a tie-up in the traffic congestion together with the machine the barrier section that contains the divider also moves leading to the breadth of the lanes.

### 3. EXISTING SYSTEM

Zipper machines or road zipper which is put together referred to as barrier transfer machines, unit of measurement vehicles are normal transport material lane road divider like Jersey wall, the measurement unit of normal soften delay all over the busy hours. Various areas concisely throughout the building work. Lanes which are constructed by the tools are usually termed as zipper lanes. The gain of these systems on top of various managing systems such as coned, directing light above solid systems. A practical barrier avoids the accident as a result the traveller overlap the other side of traffic. The disadvantage using this existing system is that the width of the lanes is slightly reduced.



**Fig -1:** Working of existing system

### 4. PROPOSED SYSTEM

In this proposed system of the automatic movable road divider, we use a system which consists of node MCU (Micro Controller Unit) and the IR(InfraRed) sensor used in measuring the traffic density in tis case and the dividers normal and extended. We are not using the

machine and operating it manually rather making it operate automatically. With this proposed intelligent system, we likely to dump of holding dependency on traffic and guide mediation, then a smart traffic can be used any side of the city. A movable road divider gives the best result for the problems faced by the public successfully. It can be mostly possible through IOT. In this system we use IR sensors which is sensible in traffic density and the purpose is to provide the digital data to node MCU and Wi-Fi module. This system helps in the better traffic networking and reduce the traffic.

### 5. WORKING OF THE PROPOSED

The working of this proposed consists of the hardware requirements. EEPROM which stands for Electrically Erasable Programmable Read Only Memory is a kind of laptop chip that can be written and re-written with the instructions(codes). Noticing it as an electrically erasable meant that electric current could be used to erase it that could be reused again. This is different from RAM. An IR sensor could detect the motion as well as the heat of the object. These IR sensors measures infrared radiation rather than emitting it and called as passive IR sensor. In this infrared spectrum all the objects radiate some forms of the thermal radiations which are invisible to our eyes, that can be detected by an IR sensor. The other required parts are LED's, Buzzer, servo motors and node controller unit. The proposed has three IR sensor so that it sense density and has a range of 10cm. These sensors which we use provide the digital data to the microcontroller unit which is Arduino uno motherboard (node MCU esp8266 Wi-Fi module).

Arduino board has a program to monitor the traffic density based on the sensor inputs. According to these three sensors the traffic density is calculated based on these sensors. If the three sensors are sensed such that sensor 1 & sensor 2 & sensor 3 then the traffic density is HIGH. If the sensor 1 & sensor 2 are sensed then the traffic density is MEDIUM. If the sensor 1 is sensed then the traffic density is LOW. This how with the help of the IR sensors we are monitoring the traffic density and then we use the servo motors in which they move the road divider according to the traffic density given by the sensors. We can stream the traffic density over an IOT application in which we can get by typing the IP address of the area. For example the IP address of Begumpet area is 192.168.4.1. In this we are using the ESP-01 Wi-Fi module so as to send the data to the traffic control room.

This data helps in the traffic congestion and can know the traffic density through the IOT application. This entire proposed system runs with the 5V DC. We have an adapter circuit which takes the input of 240V and gives the 9V DC output and this 9V is regulated to 5V.

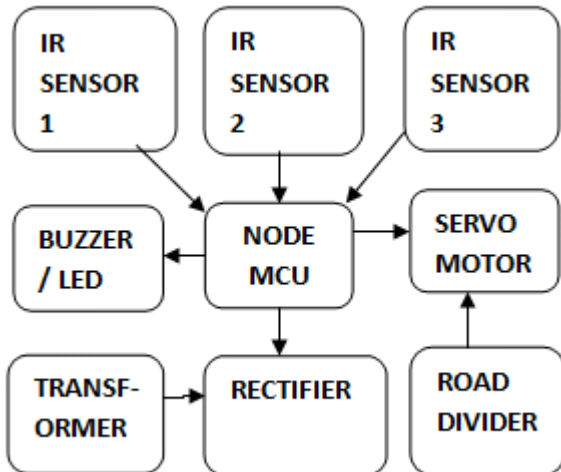

Fig -2: Working diagram

### 5.1 ESP-01 WI-FI MODULE

ESP8266 is a self-contained and a complete network solution which can carry the software applications. When the device is mounted and as the only application of the application processor, a flash memory could be started directly from an external move.

Built-in cache memory would help to improve the system performance and to reduce the memory requirements. Storage capacity and processing on ESP8266 powerful piece, it can be integrated via GPIO ports sensors and other applications specific equipment so as to achieve the lowest early in the operation and development of system resources.

The system is specifically for the wearable electronics, mobile devices and the network application structure.



Fig -3: ESP-01 module

## 6. RESULT

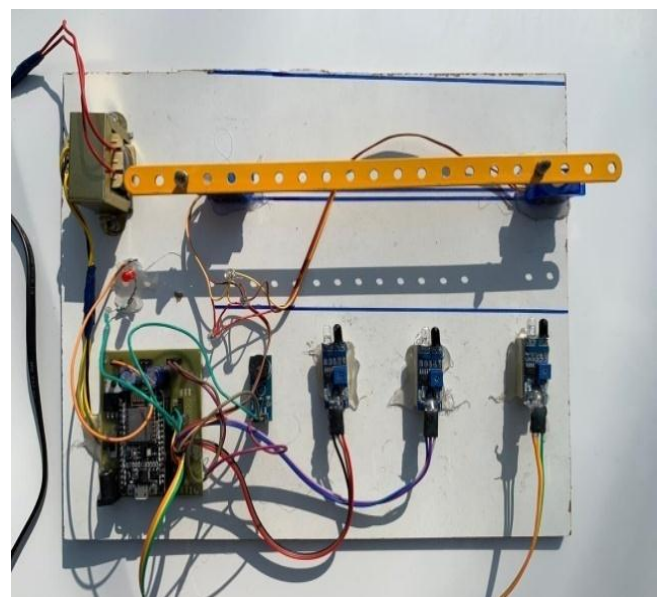

Fig -4: Design of the proposed system

## 7. CONCLUSION

Many emerging countries all over the world are facing the poor traffic network. Many metropolitan cities have poor traffic networking management with most of the population and automobiles. This system is incredibly helpful compared with the existing system which could be able to facilitate the general public to travel quick in significant traffic in time. With this smarter system proposed below the manual traffic coordination is reduced and this also reduces the manual dependency. Like this proposal of the good traffic is done in three levels of traffic density which are less, average and large density of traffic and are shown through IOT server.

This system provides a strong resolution for the traffic downside. In the future it can be automatically operated. Location based services could be integrated

to the system and it could be able to detect high traffic density automatically using the image processing.

## REFERENCES

- [1]. Shabbir Bhusari, "Traffic system mistreatment Raspberry-pi", world Journal of Advanced Engineering Technologies ISSN (Online), Volume 4, Issue 4- 2015, pp 413-415.
- [2]. K. Vidhya, A. Bazila Banu, "Density primarily based traffic light System", International Journal of Innovative analysis in Science, Engineering and Technology, Volume 3, Special Issue three, March 2014, pp 2218 – 2223.
- [3]. S. Lokesh, "An adaptational control System mistreatment Raspberry PI", International journal of engineering sciences & analysis Technology, IEEE conference June 2014, pp 831-835.
- [4]. Dietmar P. F. Moller, "Cyber-Physical sensible light System", Clausthal University of Technology, Institute of Applied Stochastics and research, IEEE 2015, pp 546-551.
- [5]. Soufiene Djahel, "Reducing Emergency Services reaction time in sensible Cities: a complicated adaptational and Fuzzy Approach", IEEE 2015, pp 978-986.