

Lateral Performance of Foamcrete Cold Formed Steel Shear Wall

Swathi M Nair¹, Amrutha B²

¹PG Student, Dept. of Civil Engineering, MGM College of Engineering & Technology, Kerala, India

²Assistant Professor, Dept. of Civil Engineering, MGM College of Engineering & Technology, Kerala, India

Abstract – Precast prefabricated panel construction is gaining more and more attention in the construction field due to their easy and speedy construction techniques. In this paper a new concept is introduced called Foamcrete Cold Formed steel Shear Wall (FCFSW). FCFSW is a type of sandwich panel which comprises of light weighted material framed with cold formed steel. The work mainly includes the lateral performance of FCFSW and its influence against openings, provided in the model against lateral loading using ANSYS software. Mainly six full scale model is included in this paper. Based on the result obtained it was seen that the lateral performance of the wall is altered while openings are provided. And it also concluded that by the proper designing of the opening provided in the wall will helps to reduce the reduction in the lateral performance when openings are introduced.

Key Words: Foamed Concrete, Shear Wall, CFS Frame, ANSYS Workbench, CFRP rod, sandwich panel.

1. INTRODUCTION

Foamcrete being a light weighted material is used as a load bearing and non-load bearing structure which is incapable of carrying the lateral load acting on it. But its capacity can be increased by the application of some hybrid system. Also, the seismic performance of the light weighted steel frame such as cold formed steel is not so satisfactory, but its capacity can also be increased by the application of some hybrid system. There are a number of researches that has already been conducted which proves that by the proper designing methods the load carrying capacity of these materials can be increased.

Zhifeng Xu et.al, [1] conducted an experimental study on the comparison of seismic behavior of Cold Formed Steel (CFS) shear wall containing straw boards on both sides with the Cold formed Steel High strength Foamed Concrete (CSHFC) shear wall having straw board on both sides. Resulting in the conclusion that CSHFC shear wall have better performance than the CFS shear wall.

Noridah Mohamad et.al, [3], investigated the suitability of Foamed Concrete Sandwich (FCS) wall as a load bearing wall. They also performed the comparative study regarding the performance of the wall having steel truss shaped shear connector of single layer and double layer. Based on their investigation they arrived at the conclusion that the double

layer shear connector provides higher stiffness than the single layer hence, it carries higher load with lesser deflection.

In this paper a modified model of the FCS wall is created using foamed concrete wythes, expanded polystyrene core, CFRP reinforcement, shear connector and CFS frame, called FCFSW is created and its lateral performance is checked and also the influence of the model against opening under lateral load is carried out.

1.1 Objectives

The main objective of this study is to develop and analyse composite shear wall made of foamcrete and the cold formed steel. For the analysis and modelling of shear wall, ANSYS software is used. Lateral performance of the FCFSW is carried out by using non-linear static analysis. Structural performance of wall made of CFRP is carried out in this paper. Also, the study on the influence of openings in the structure is also performed.

1.2 Scope

- The work is limited to strengthen the foamed concrete sandwich wall against lateral force using light weighted material.
- The size of the panel is limited to only 1000mm*375mm*70mm.
- This study is limited to modelling and analysis of FCFSW using the ANSYS software.
- The study is limited to structural performance of FCFSW under lateral load.
- The study is limited to the study of wall only.

2. FINITE ELEMENT MODELLING

2.1 General

In this study FCFSW model of size 3000mm*2250mm*70mm is generated by connecting small panels FCFSW of size 1000mm*375mm*70mm. 6 panel are connected in width wise and 3 panels in height wise to make the desired size of wall. The model is made up of foamed concrete, expanded polystyrene as core material sandwiched between two foamed concrete wythes. The connection between the wythes are ensured by the double layer CFRP rod shear connector

provided at an angle of 45 which is connected to the reinforcement provided in the foamcrete, this whole sandwich material is then framed using CFS frame. Three-dimensional models were developed to study the performance of wall using the ANSYS software. Once the modelling of wall is finished, it is analyzed under lateral load.

2.2 Material Properties and Specification of Model

In this study the compressive strength of the foamcrete wythes used is 7.5MPa and its corresponding Poisson’s ratio and young’s modulus being 0.2 and 12000MPa respectively, expanded polystyrene having yield strength 7.5MPa and that of Poisson’s ratio and young’s modulus of 0.2 and 0.8963MPa is used as the core material [3]. CFS frame of yield strength 384MPa, Poisson’s ratio 0.3 and young’s modulus 2.0×10^5 MPa [1] is provided and that of CFRP rod of yield strength 1899MPa Poisson’s ratio 0.3, young’s modulus 140000 MPa [11] used as the shear connectors. The specifications of the small-scale model of FCFSW are listed below in the table 1.

Table -1: Specification of small-scale model of FCFSW

Height of the panel (H)	1000mm
Width of the panel (W)	375mm
Overall thickness of panel (t)	70mm
Thickness of wythes of panel (t1)	20mm
Thickness of core of panel (t2)	30mm
CFRP reinforcement provided on wythes (both horizontal and vertical)	6mm @75mm c/c spacing
CFRP shear connector provided	6mm @ 75mm c/c spacing
Width of flanges of CFS channel section, $w_1 = w_2$	50mm
Width of web of CFS channel section, w_3	70mm
Thickness of CFS channel section, $t_1 = t_2 = t_3$	1.2mm

2.3 Modelling and Analysis

The wall is modelled using the ANSYS Workbench 16.1 software. First the engineering properties of the material required for the model designing were assigned. Then the model is created based on the specifications provided in the above table, after that the conditions regarding the connection between different material are assigned as bonded, later the support condition is provided with top end free and the bottom end fixed. Loading conditions were provided as displacement-controlled method. Meshing is generated by the software automatically; every model was meshed using a 3D-20 noded quadratic element solid 186 in order to improve accuracy in analysis by the software itself. In this paper before the full-scale model of FCFSW is prepared its small scaled panel is created first and its fig is shown below. Fig -1 shows the isometric view of the single panel of FCFSW of size 1000mm*375mm*70mm and the arrangement of shear connector and that of the CFS frame provided in the panel.



Fig -1: Isometric view of single panel of FCFSW

Now the full-scale model of FCFSW is created by connecting these panels in width wise and that of height wise to form a full-scale model of size 3000mm*2250mm*70mm as shown in fig -2 and its lateral performance is investigated.

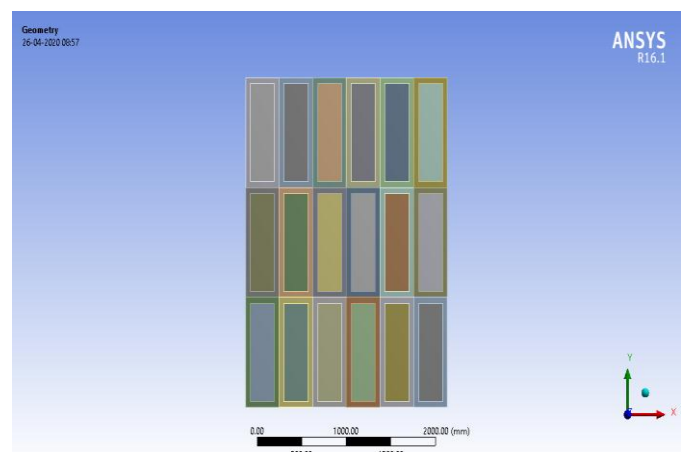

Fig -2: Front view of full scaled model of FCFSW

Fig -3 to fig -8 shows the different opening conditions of door and widow provided in the model.

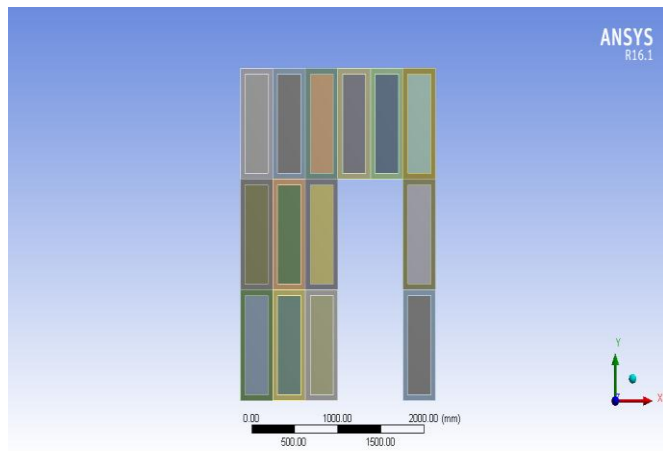

Fig -3: Front view of door opening case 1

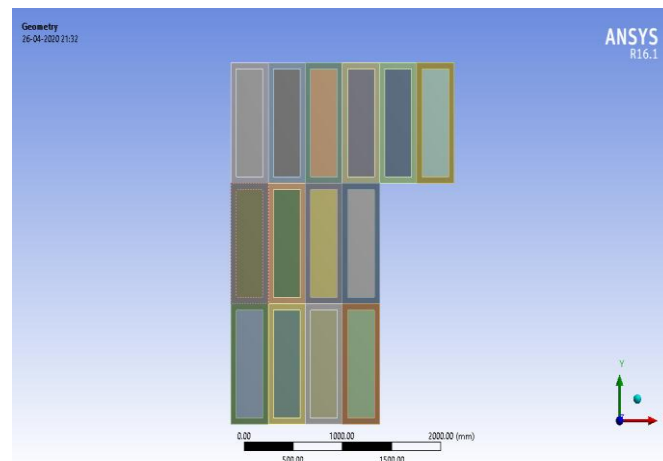

Fig -4: Front view of door opening case 2

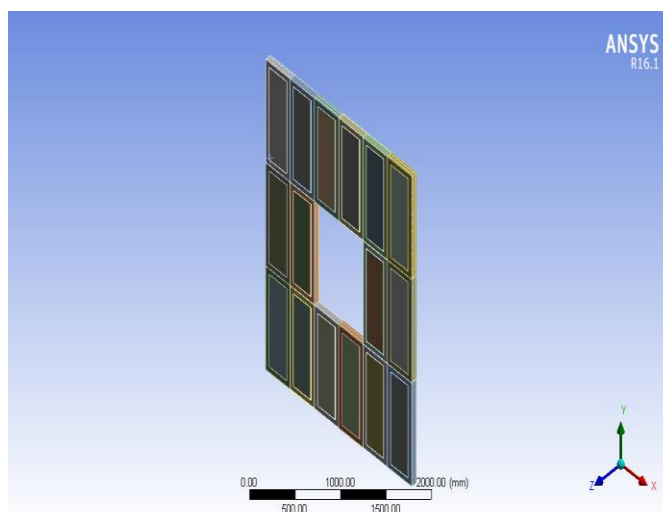

Fig -5: Isometric view of window opening case 1

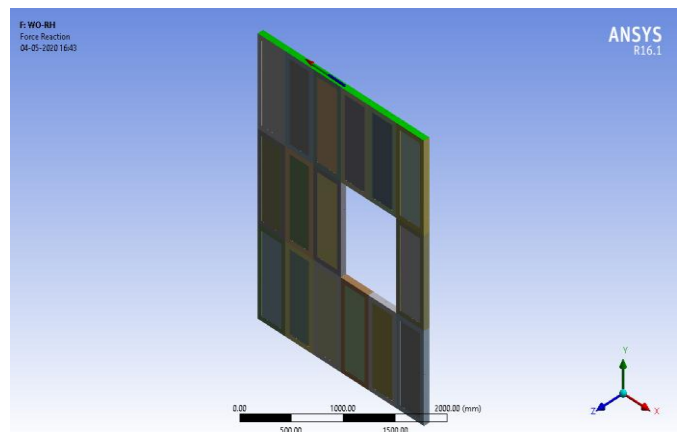

Fig -6: Isometric view of window opening case 2

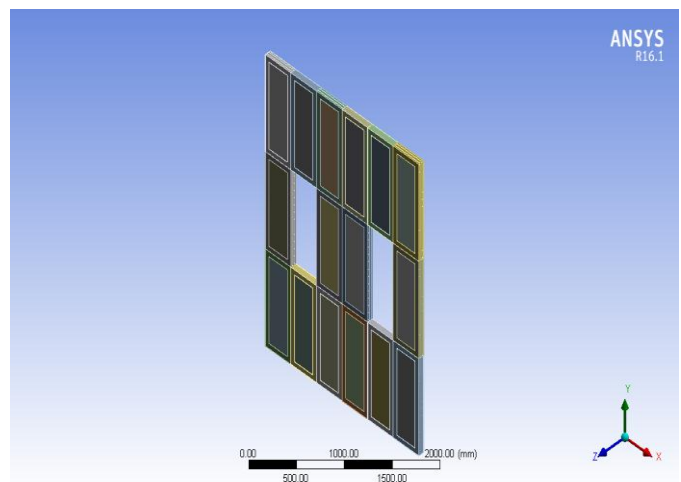

Fig -7: Isometric view of window opening case 3

3. RESULT AND DISCUSSIONS

The deformation occurred in the corresponding model under displacement control method in the lateral manner is shown in the figures below.

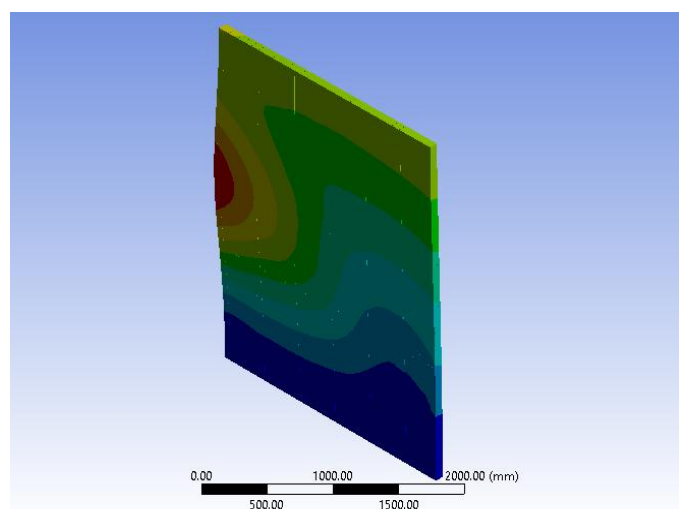

Fig -8: Isometric view deformation occurred in the FCFSW

Based on the results obtained from the study conducted the ultimate load carrying capacity of the FCFSW is 2814kN and the corresponding deformation is 66.977mm. When the influence of the door opening of size 750mm*2000mm provided at two different position is analyzed the ultimate load carrying capacity of the model having door opening provided at the right of the section of the wall leaving a panel from the extreme end is seen to be 2051.7kN and the corresponding displacement being 101.27mm. Load carrying capacity of the model is having door opening provided at the extreme end of the wall is only 1416.6kN and corresponding displacement being 117.6mm. The fig -9 and fig -10 shows the deformation occurred in the respective model having door openings.

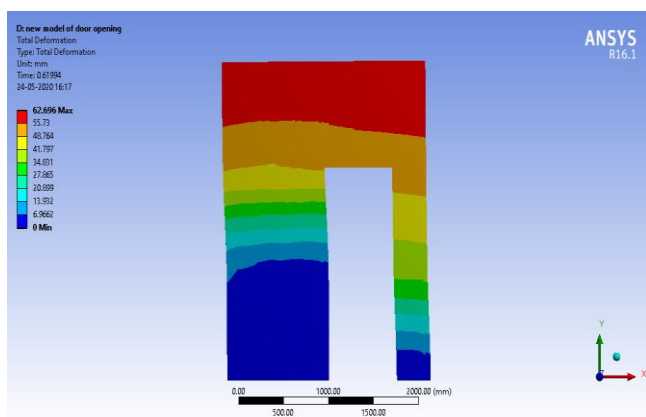

Fig -9: Front view of deformation in door opening case 1

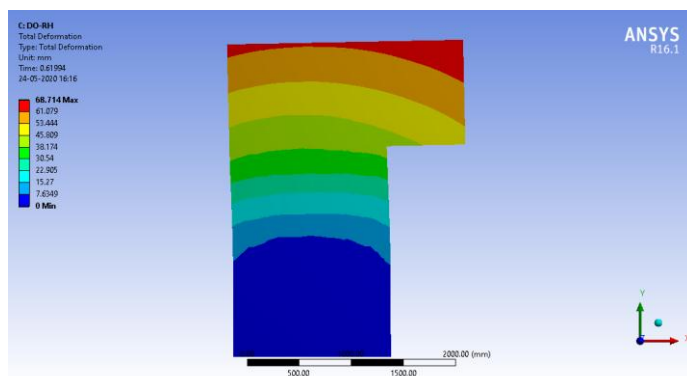

Fig -10: Front view of deformation in door opening case 2

The following fig -11 to fig -13 shows the deformation occurred in the model containing window openings provided in the FCFSW. The model containing window opening of size 750mm*1000mm at the centre of the wall resulted in the ultimate load carrying capacity of about 2211.1kN and its corresponding deformation being 232.25mm. In the case when the window opening is provided at the right section of the wall leaving a panel from the extreme end the ultimate load carrying capacity is 2449.6kN and its corresponding deformation being 125.5mm.

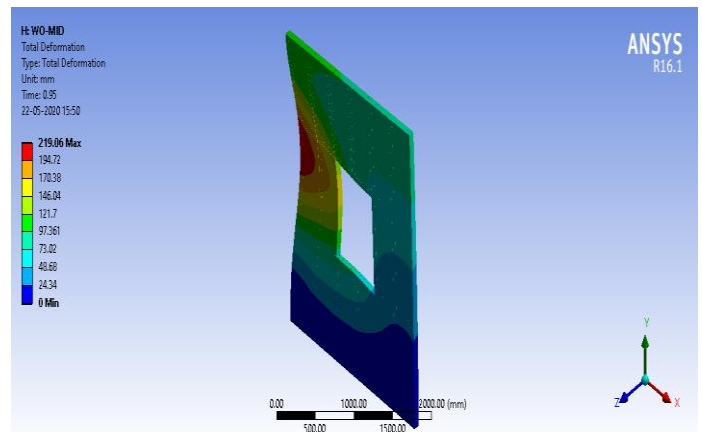

Fig -11: Isometric view of deformation in window opening case 1

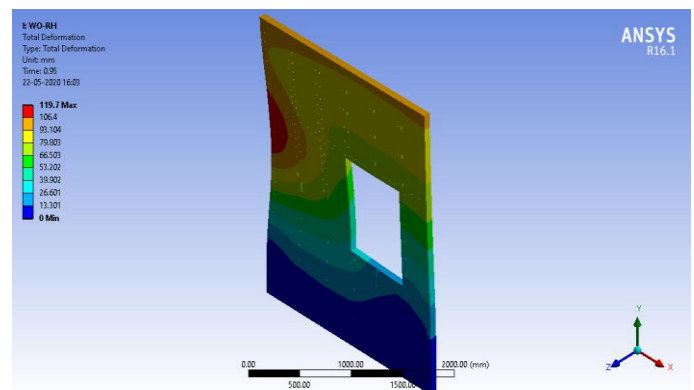

Fig -12: Isometric view of deformation window opening case 2

And the ultimate load carrying capacity and the displacement for the case when window opening of size 375mm*1000mm is provided in two position leaving a space between the opening is 2274.6kN and 166.41mm respectively.

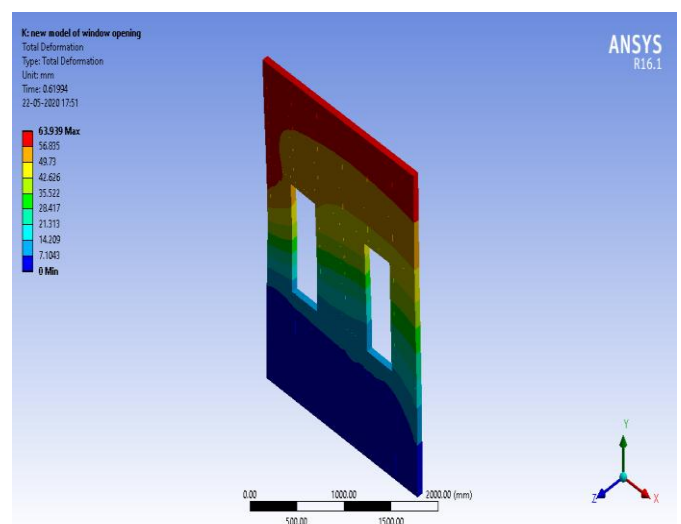

Fig -13: Isometric view of deformation window opening case 3

The results obtained for each model is noted from the software, and a comparative chart is prepared based on the load deflection curve plotted for each model. Chart -1 shows the comparative chart plotted between FCFSW without any opening and FCFSW with door opening cases. From the chart -1 it is clearly seen that providing opening in the wall will reduce its load carrying capacity, also it increases the deflection occurred in the model under load. This may be due to the decrease in the stiffness of the model when an opening being provided in it. It is also clear that the opening provided in the right of section of the wall leaving a panel from the extreme end i.e., case 1 condition of door opening has shown lesser impact under lateral load than the model containing door opening at extreme portion of the wall.

About 27.09% decrease in the load carrying capacity is seen in the door opening case 1 than that of the FCFSW model having no openings in it, and its corresponding increase in the deformation being 51.201% is noticed. While in the case 2 condition of the door opening about 49.659% decrease in the load carrying capacity is seen and its corresponding increase in the deformation of the model is seen about 75.583%.

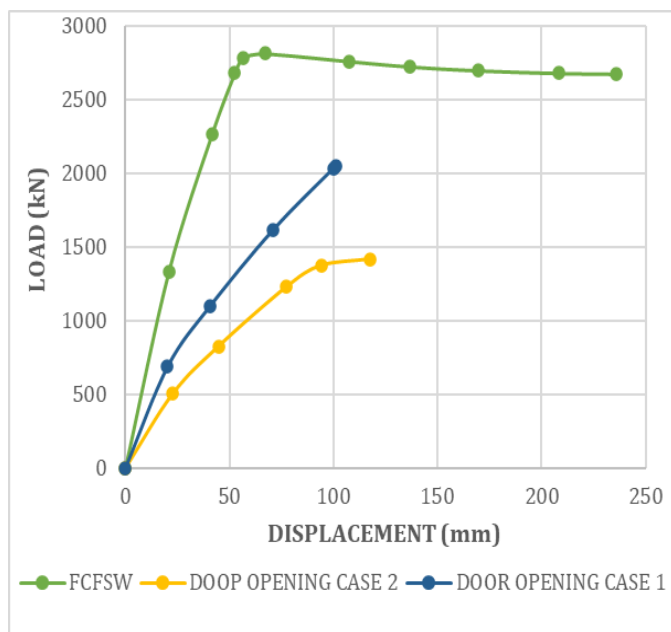

Chart -1: Comparison of FCFSW with door opening cases

Whereas the chart -2 is a comparative graph of models with window opening cases in FCFSW and that of model without any opening provided in FCFSW. As in the previous case in this chart also it is clearly seen that when openings are provided it will reduce the load carrying capacity in the model and also increases the displacement occurred in the model under loading condition.

In the window opening condition case 1 the ultimate load carrying capacity of the wall is decreased to 21.425%. When

the window opening condition 2 is applied about 12.95% decrease in the load carrying capacity of the model is observed.

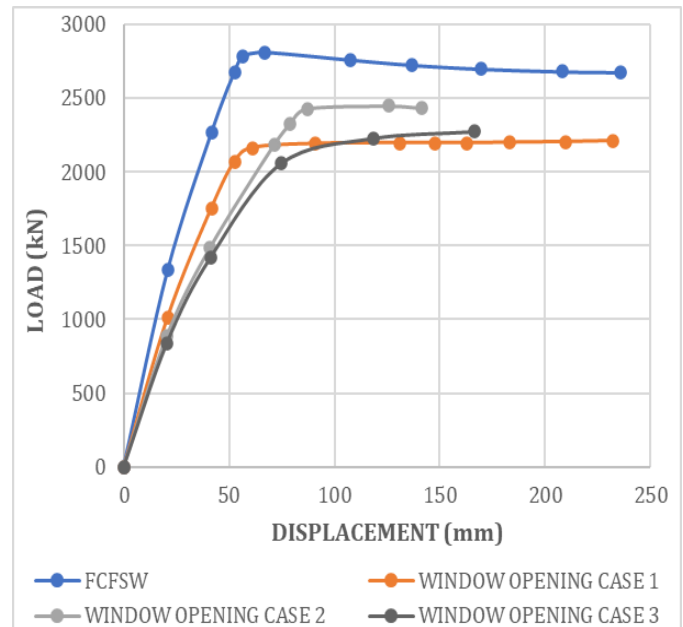

Chart -2: Comparison of FCFSW with window opening cases

In the case 3 condition of window opening about 19.168% decrease in the load carrying capacity of the model is experienced than the model having no openings provided in it.

4. CONCLUSIONS

This study was mainly conducted to evaluate the lateral performance of the FCFSW and also the influence of the model under different type of opening such as door and window. From the data obtained from the analytical study that has been conducted on the FCFSW model the ultimate load carrying capacity of the model under lateral load carrying obtained was 2814kN with the displacement of 66.977mm.

Based on the result the main conclusion in which the data arrived are following:

- Due to the high ductile property of CFRP rod the deformation occurred in the model under load is high, even though the load carrying capacity of model is high.
- Significant variation in the load carrying capacity and that of the displacement is seen when openings are provided.
- Door opening case 1 condition, provided by leaving a panel before providing opening showed better performance than another model. About 27.09%

decrease in the load carrying capacity was seen than the model having no openings in it.

- While performing the window opening condition case 2, opening provided at the top right of the section of model showed better performance than other models.
- The proper designing of the opening provided in the model will result in reduced reduction of the ultimate load carrying capacity of the model and also reduction in deformation.

REFERENCES

- [1] Zhifeng Xu, Zhongfan Chen, Bashir H Osman and Suhan Yang (2018), "Seismic Performance of High Strength Lightweight Foamed Concrete - Filled Cold - Formed Steel Shear Walls", *Journal of Constructional Steel Research*, Volume 143, Page No. 148-161.
- [2] Mina Mortazavi, Pezhman Sharafi, Hamid Ronagh, Bijan Samali and Kamyar Kildashti (2018), "Lateral Behaviour of Hybrid Cold-Formed and Hot-Rolled Steel Wall Systems: Experimental Investigation", *Journal of Constructional Steel Research*, Volume 147, Page No. 422-432.
- [3] Noridah Mohamad, Goh Wan Inn, Redzuan Abdullah, Abdul Aziz Abdul Samad, Priyan Mendis and Massoud Sofi (2017), "Structural Performance of FCS wall Subjected to Axial Load", *Construction and Building Materials*, Volume 134, Page No. 185-198.
- [4] Abheetha Peiris and Issam Harik (2017), "Carbon fiber-reinforced polymer rod panels for strengthening concrete Bridges", *Advances in Structural Engineering*, Volume 17, Page No. 0-14.
- [5] S M Leela Bharath and P Prabha (2017), "Parametric Study on Steel-Foamed Concrete Composite Panel Systems", *International Journal of Civil Engineering*, Volume 4, Page No. 16-23.
- [6] Zhifeng Xu and Zhongfan Chen (2017), "Experimental Investigation on Cold-Formed Steel Foamed Concrete Composite Wall under Compression", *International Journal of Civil and Environmental Engineering*, Volume 11, Page No. 1257-1263.
- [7] Yang Ding, En-Feng Deng, Liang Zong, Xiao-Meng Dai, Ni Lou and Yang Chen (2017), "Cyclic Tests on Corrugated Steel Plate Shear Walls with Openings in Modularized Constructions", *Journal of Constructional Steel Research*, Volume 138, Page No. 675-691.
- [8] Nader K.A. Attari, S. Alizadeh and S. Hadidi (2016), "Investigation of CFS Shear Walls with One and Two-Sided Steel Sheathing", *Journal of Constructional Steel Research*, Volume 122, Page No. 292-307.
- [9] Y H Mugahed Amran, Raizal S. M. Rashid, Farzad Hejazi, Nor Azizi Safiee and A. A. Abang Ali (2016), "Structural Behaviour of Laterally Loaded Precast Foamed Concrete Sandwich Panel", *International Journal of Civil and Environmental Engineering*, Volume 10, Page No. 270-278.
- [10] Bin Liu, Ji-Ping Hao, Wei-Hui Zhong and Hao Wang (2016), "Performance of Cold-Formed-Steel-Framed Shear Walls Sprayed with Lightweight Mortar under Reversed Cyclic Loading", *Thin-Walled Structures*, Volume 98, Page No. 321-331.
- [11] Mohammad Z Afifi, Hamdy M Mohamed and Brahim Benmokrane (2014), "Strength and Axial Behavior of Circular Concrete Columns Reinforced with CFRP Bars and Spirals," *Journal of Composite Constructions*, Volume 18, Page No. 1-10.
- [12] M. Gerami and M. Lotfi (2014), "Analytical Analysis of Seismic Behavior of Cold-Formed Steel Frames with Strap Brace and Sheathings Plates", *Advances in Civil Engineering*, Volume 2014, Page No. 1-23.
- [13] G Sopal, S.Rizkalla and L.Sennour (2013), "Shear Transfer Mechanism of CFRP Grids in Concrete Sandwich Panels", *Fourth Asia Pacific Conference on FRP in Structures*, Page No. 0-12.