

## Pollution Detection and Control using IoT

Saeed Arun Kamble<sup>1</sup> Bhakti Kishor Hedau<sup>2</sup> Sudhanshu Kumar<sup>3</sup> Prof. Minaj Shikalgar<sup>4</sup>

<sup>1,2,3</sup>BE Student <sup>4</sup>Assistant Professor

<sup>1,2,3,4</sup>Department of Electronics & Telecommunication Engineering

<sup>1,2,3,4</sup>KIT's College of Engineering, Kolhapur, Maharashtra, India

\*\*\*

**Abstract-** Air and water pollution is growing issue these days. It is necessary to monitor air quality and keep it under control for a better future and healthy living for all. Here we propose an air quality as well as water pollution monitoring system that allows us to monitor and check live air quality as well water pollution in particular area through IOT. Here we propose an automated fabrication for the detection of the air and water pollution level. The fabrication consists of sensors, purifier, motors, valves, water pipes and water tanks. Thus, this proposes an integrated approach of detection and controlling of pollution increasing on our earth.

**Key Words:** Microcontroller, Sensor, Valve, Purifier, Motor, Pipes and Water tank

### I . INTRODUCTION

Some of the research work made for monitoring the pollution parameter in a particular location in order to make the environment safe and the area smart. Different method were used in the past that are mentioned in this section. Firstly, smart environment monitoring using wireless sensors in which the main focus was on the developing an environment free of pollution by making it smart. The system uses air sensor to check the presence of harmful and hazardous gases in the air. MQ135 is the air sensor which is used to collect the air pollutant. This sensor interact with microcontroller which process the data and then it is transmitted. We have a LCD display. The entire system is powered by 12V supply.

### II . HARDWARE REQUIREMENTS

#### A. Transmitter Section:

It consists of,

- 1) Microcontroller
- 2) ESP8266
- 3) Pollution Controller
  - (a) Valve 1
  - (b) Motor 1
  - (c) Sensor 1

4)16\*2 LCD Display

5) MQ135

#### 1) Microcontroller:

The P89V51RD2 is an 80C51 microcontroller with 64 kb Flash and 1024 bytes of data RAM. A key feature of the P89V51RD2 is its X2 mode option. The design engineer can choose to run the application with the conventional 80C51 clock rate (12 clocks per machine cycle) or select the X2 mode (6 clocks per machine cycle) to achieve twice the throughput at the same clock frequency. Another way to benefit from this feature is to keep the same performance by reducing the clock frequency by half, thus dramatically reducing the EMI. The Flash program memory supports both parallel programming and in serial In-System Programming. Programming mode offers gang-programming at high speed, reducing programming costs and time to market. ISP allows a device to be reprogrammed in the end product under software control. The capability to field/update the application firmware makes a wide range of applications possible. The P89V51RD2 is also In-Application Programmable (IAP), allowing the Flash program memory to be reconfigured even while the application is running.

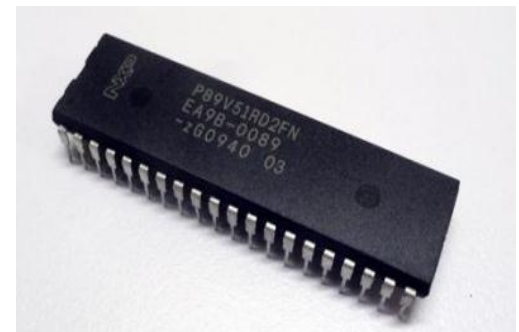

#### 2) ESP8266

The ESP8266 is a low-cost Wi-Fi microchip, with a full TCP/IP stack and microcontroller capability, produced by Espressif Systems in Shanghai, China. The chip first came to the attention of Western makers in August 2014 with the ESP-01 module, made by a third-party manufacturer Ai-Thinker. This small module allows microcontrollers to connect to a Wi-Fi network and make simple TCP/IP connections using Hayes-style commands. However, at

first there was almost no English-language documentation on the chip and the commands it accepted. The very low price and the fact that there were very few external components on the module, which suggested that it could eventually be very inexpensive in volume, attracted many hackers to explore the module, the chip, and the software on it, as well as to translate the Chinese documentation chip, and the software on it, as well as to translate the Chinese documentation.

The ESP8285 is an ESP8266 with 1Mib of built-in flash, allowing building of single-chip devices capable of connecting to Wi-Fi.

### 3) MCP3204

Features:

12-bit resolution  $\pm 1$  LSB max DNL  $\pm 1$  LSB max INL  $\pm 2$  LSB max INL 8 (MCP3208) input channels Analog inputs programmable as single-ended or pseudo-differential pairs On-chip sample and hold SPI serial interface (modes 0,0 and 1,1) Single supply operation: 5.5V 100 kbps max. Sampling rate 5V 50 kbps max. Sampling rate at VDD = 2.7V Low power CMOS technology: 500 nA typical standby current, 2  $\mu$ A max. 400  $\mu$ A max. Active current at 5V Industrial temp range: to +85°C Available in PDIP, SOIC and TSSOP packages.

Description: The Microchip Technology Inc. MCP3204/3208 devices are successive approximation 12-bit Analog to-Digital (A/D) Converters with on-board sample and hold circuitry. The MCP3204 is programmable to provide two pseudo-differential input pairs or four single ended inputs. The MCP3208 is programmable to provide four pseudo-differential input pairs or eight single ended inputs. Differential Nonlinearity (DNL) is specified at  $\pm 1$  LSB, while Integral Nonlinearity (INL) is offered in  $\pm 1$  LSB (MCP3204/3208-B) and  $\pm 2$  LSB (MCP3204/3208-C) versions. Communication with the devices is accomplished using a simple serial interface compatible with the SPI protocol. The devices are capable of conversion rates to 100 kbps.

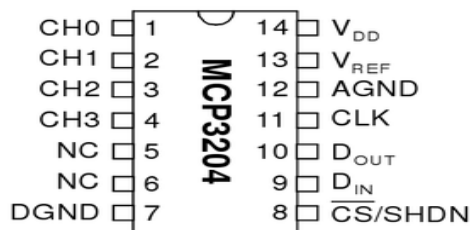

### 4) MQ135:

Features: High Sensitivity. High sensitivity to Ammonia, Sulfide and Benze. Stable and Long Life. Detection Range: 10 - 300 ppm NH<sub>3</sub>, 10 - 1000 ppm Benzene, 10 - 300 Alcohol, Heater Voltage: 5.0V, Dimensions: 18mm Diameter, 17mm High excluding pins, Pins - 6mm High, Long life and low cost.

Applications: Domestic air pollution detector, Industrial air pollution detector, Portable air pollution detector.



### 5) Turbidity Sensor

Turbidity sensors measure the amount of light that is scattered by the suspended solids in water. As the amount of total suspended solids (TSS) in water increases, the water's turbidity level (and cloudiness or haziness) increases. Turbidity sensors are used in river and stream gaging, wastewater and effluent measurements, control instrumentation for settling ponds, sediment transport research, and laboratory measurements.



### III. Working:

First step that takes place in this process is initialization. When the circuit is turned on, the ESP module gets connected successfully. The pollution controller turns on after a 10 second delay. The Valve1 & Motor1 are turned on simultaneously. Now the LCD displays the value that is been read by the input sensor.

The sensor gives a certain percentage value of the pollution detected approximately after 20 seconds delay. The valve1 and motor1 turns off. The water level is checked. If the tank is full the motor2 is ON, else motor2 OFF.

The LCD display value of polluted air for input sensor1 after 20 seconds delay, then the sprinkler starts sprinkling water on the polluted air which is passed from the pipe.

The turbidity sensor checks if the water is clean, muddy, dirty.

The sensor 2 gives the value if outgas is less than ingas and then valve 2 turns ON, else valve2 is OFF. Here the sensor 1 corresponds to ingas whereas the sensor2 corresponds to outgas.

The output is obtained from the sensor2, if the output is less than input, the valve2 opens and we obtain pure air, else it closes and we get feedback process.

**IV. BLOCK DIAGRAM**

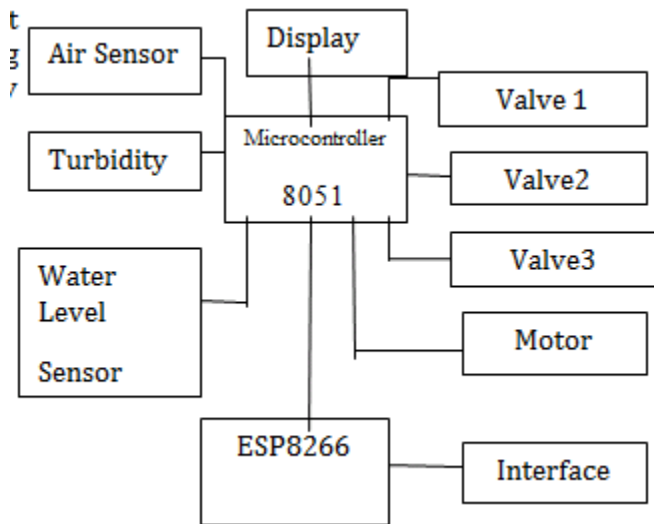

**V. CONCLUSION**

Initially, sensors provide the data to the microcontroller that is displayed on the lcd display which is connected to the microcontroller board. If the air pollutants exceeds the limit i.e defined by the programmer then the output is shown in analog form. Hence, we conclude that this project can be beneficial to the society which is suffering from humorous amount of pollution on daily basis.

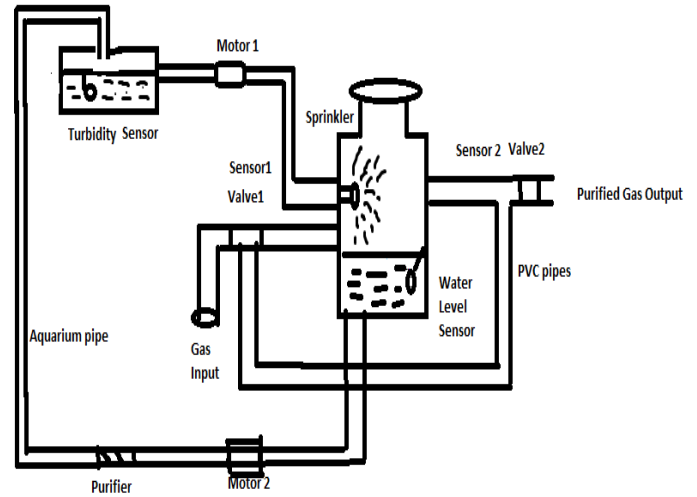

Figure: Visual Representation

The built in header files:

- <reg51.h> = 8051 register at port 2 pin 0
- <stdio.h> = input and output
- <math.h> = mathematical expression
- "lcd.h" = user defined header files therefore in "
- "UART\_gsm" = UART protocol

**VI. REFERENCES**

1. International Journal of Innovative Research in Science, Engineering and Technology (IJIRSET) Volume; 7, Issue: 5. ISSN NO. 2319-8753. IOT Based Air and Noise Pollution Monitoring and Controlling system by Sindhu.k.g, Shruthi.H, Sumanth.M.B, Vijayshree.H.M, Ayesha.A.P
2. International Journal of Pure and Applied Mathematics Volume 119 No. 15 2018, 935-941,ISSN: 1314-3395 by D.Arunkumar, K.Ajaykanth, M.Ajithkannan, M.Sivasubramanian