

E-bike with Treadmill

Sachin yograj patil¹, Vaishali Ramesh Bodke², Prachi Sharad chavare³, Akshay rajendra mhaskar⁴, Prof. Chakor A.M.⁵

^{1,2,3,4} Student, Electrical Engineering, SVIT Nashik, Maharashtra, India

⁵Assistant Professor, Electrical Engineering, SVIT Nashik, Maharashtra, India

ABSTRACT: For person voyaging has gotten fundamental. So as to continue in this quick forward world he should make a trip here and there. It is significant that time taking for voyaging ought to be less, additionally it ought to be prudent and effectively accessible. With the quick exhausting assets of petroleum and diesel, there is have to discover discontinuous decision. The primary point of this survey paper is to introduce tackling the different vitality and use it in the present presence of human life. The focal point of this undertaking is to perform power counts and framework structure of this Electric Bike. This bicycle can be driven with the assistance of power or likewise with the assistance of sun powered vitality. In this manner the assembling of such bicycle is crucial.

Key Words: Solar Panel, Battery, Wiper Motor, Motor (permanent magnet DC motor).

1. INTRODUCTION:

Bikes are one of the most omnipresent types of transportation on the planet. Most kids recollect their first bicycle; with it came the opportunity to investigate their reality with more opportunity than any time in recent memory. As we develop, be that as it may, bicycling turns out to be something other than a youth soul changing experience. Wind in our hair and feet on the pedals, we have a few valid justifications to jump on and travel. A significant part of the world uses bikes as an essential type of day by day transportation. What might take a few hours of movement by walking turns out to be quicker and progressively proficient on two wheels. A few cyclists take trips across whole states or crosscountry exclusively on a bike. Arriving at paces of 15 miles or 30 km an hour is attainable by starting cyclists, while progressively experienced riders can arrive at speeds identical to car

travel. Not to be compelled by basic transportation, bikes (fixed and something else) have helped individuals gotten more advantageous by losing abundance weight and improving cardiovascular wellness. The activity advantages of cycling are notable.

2. PROBLEM STATEMENT:

Present advanced world, there are two primary issues which are messing up humankind is the an unnatural weather change which is brought about by broad utilization of combustibles and cars in any event, for short separations too. Because of this there is a gigantic impact on condition and furthermore exhaustion of fuel sources. The subsequent concern is that part of individuals are presently significantly experiencing fledgling medical problems. This is on the grounds that absence of appropriate exercise. So the new spearheading thought in current transportation world and named as sunlight based fueled wellbeing bike which can make individuals walk while they ride.

3. METHODOLOGY:

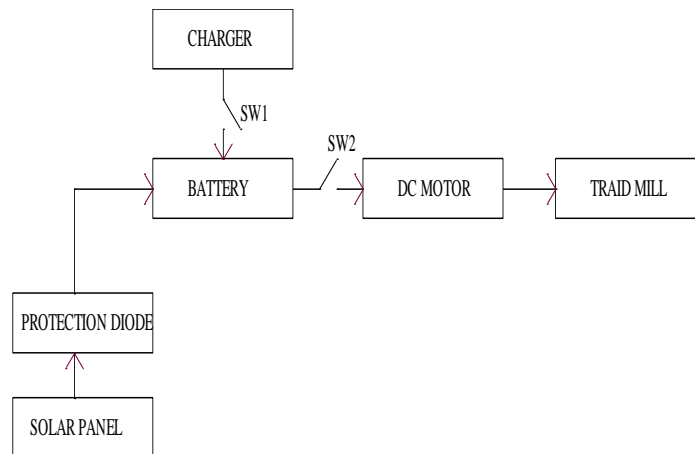

Fig: Working Model Block Diagram

A sunlight based electric bicycle with exchange factory is an electric vehicle powered completely or significantly by

direct solar vitality. Usually, photovoltaic (PV) cells contained in sun oriented boards convert the sun's vitality legitimately into electric energy. Solar force might be likewise used to give capacity to interchanges or controls or other helper capacities. In this task Rechargeable battery is utilized with long life for charging DC electric engine. Here electric motor convert's electrical energy into mechanical energy. Most electric motors work through the cooperation of magnetic fields and current-carrying conductors to create power The power produced by the sun powered board is put away in the battery, empowering a rider to switch over the activity to half breed mode whenever and control the speed of the bike utilizing the quickening agent Solar boards assimilate UV light and convert it to clean power which is then used to revive the bike's battery. Riding bikes is now an eco-accommodating approach to drive.

4. System Implementation:

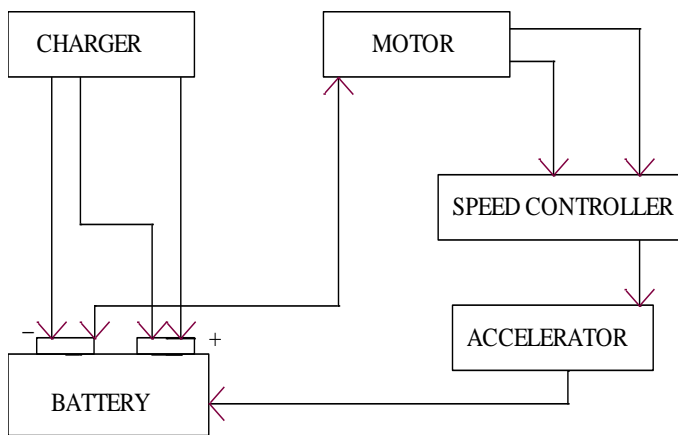

Fig. Circuit diagram

Sun powered vitality is caught from the sun utilizing sun powered boards mounted on the backside of the bike. These boards are associated with a lift converter in order to help the voltage to the necessary level. The game plan is additionally associated with a battery. The battery is charged utilizing this sun powered yield as the whole force move is DC for this situation. This battery is associated with a DC engine. The battery can likewise be charged utilizing a divider charger in the event of nonappearance of sun. A brushless DC engine is favored here on account of no support, high effectiveness, and low clamor and

furthermore as a result of the nonappearance of brushes we don't discover starting in a BLDC engine. A synchronized engine controller is utilized here for the working of the engine. Additionally a throttle is utilized here to speed up the cycle. This quickening agent is additionally straightforwardly associated with the engine controller which thus controls the engine speed. The bike can likewise be run utilizing mechanical accelerating without sun or when the battery is depleted out.

Loads on Bicycle:

Table: solar module rating

Parameter	Value
Maximum Power (Watt)	100
Optimum Operating voltage	18.9V
Open Circuit Voltage Voc	22.5V
Optimum Operating Current (Imp)	5.29A
Short Circuit Current Isc	5.75A

Table: Specifications of Hub Motor

Parameter	Corresponding factor/value
Type of Motor	Hub motor
Design of Motor	BLDC (Brushless DC)
Power Rating	350W
Rated Voltage (V)	36
Weight(kg)	5
Efficiency (%)	80
Torque	12 N-m
Speed (rpm)	328

Table: Specifications of Motor Controller

Parameter	Values
System voltage (V)	36
Rated current (A)	27
Under voltage protection (V)	31.5
Ambient temperature (°C)	0-50

Table: Specifications of Battery

Parameter	Corresponding factor/value
Type	Lead Acid
Number	three Batteries
Voltage	36 V DC
Wattage	350W
Rated speed	3000 RPM
No load Speed	3850RPM
Max. Continuous Discharge current	15A
Max charge voltage	40.6 V
connected in	Series
Amp-Hour Rating	10 Ah
Discharge cutoff voltage	15 V DC

- Extends the riding range – 30kms on a solitary charge. Lesser support cost.
- Normal accelerating is conceivable when not on power help mode.
- Detachable battery can be taken inside the house for charging
- Solar boards continue charging the batteries for our persistent use. No gas - no oil - no check ups.
- The fan produce power and thus the battery is charged.
- No enrollment - no protection – no driver's permit

Parameter	Corresponding factor/value
Torque	32Nm
Speed	3520RPM
No Load (rpm)	290;250
Full load (rpm)	255;220
Charging time	8 hours
Discharging time	10 minutes
Overall distance covered	1.5 km
Load Capacity	40Kg

5. DESIGN CALCULATION:

Sr. No.	Component	Material	Dimensions (mm)
1	Chassis	Stainless steel	35
2	Fork	Stainless steel	40
3	Bicycle axle	SAE 1010 Steel	10
4	Handle	Cast Aluminium	25
5	Treadmill	Stainless steel	12
6	Roller	Mild steel	20
7	Side frame	Aluminium alloy	70 30



6. RESULTS:

- Commuting with low exhaustion at a top speed of 24 km ph.

7. CONCLUSION:

This bike is less expensive, less difficult in development and can be broadly utilized for short separation voyaging particularly by younger students, understudies, office goers, locals, mailmen and so on. It is especially reasonable

for youthful, matured, handicap individuals and cooks the need of monetarily poor class of society. The most significant element of this bike is that it doesn't devour important petroleum products in this manner sparing corners of remote monetary standards. Running on treadmill is simpler than running on a proportionally level separation outside in light of the fact that the ground is smooth and there is no wind obstruction. It is eco-accommodating and contamination free, as it doesn't have any emanations. It will be a modest option for the suburbanite. A great many people, on their drive to work, go under 40km. Its cleaner and you never need to purchase gas or replace the oil. This task is prompting a contamination free condition.

8. FUTURE SCOPE:

To overcome this discharge problem we can generation of electricity by using dynamo generator. The mechanical energy generated by human due to walking on tread belt is converted to electrical energy by using dynamo generator.

REFERANCES:

- [1] Yashwant Sharma¹, Praveen Banker², Yogesh Raikwar³, Yogita Chauhan⁴, Madhvi Sharma." R&D ON ELECTRIC BIKE", International Research Journal of Engineering and Technology (IRJET Feb-2018).
- [2] Christian Gorenflo, Ivan Rios, Lukasz Golab, and Srinivasan Keshav, "Usage Patterns of Electric Bicycles: An Analysis of the WeBike Project", Journal of Advanced Transportation Volume 2017, Article ID 3739505, 14
- [3] Kunjan Shinde, "Literature Review on Electric Bike", IJRMET Vol. 7, Issue 1, Nov 2016 - April 2017
- [4] D. M. Sousa, P. J. Costa Branco, J. A. Dente," Electric Bicycle Using Batteries and Supercapacitors", DOI: 10.1109/EPE.2007.4417425 · Source: IEEE Xplore
- [5] Ian Vince McLoughlin, I. Komang Narendra, Leong Hai Koh, Quang Huy Nguyen, Bharath Seshadri, Wei Zeng, Chang Yao, "Campus Mobility for the Future: The Electric Bicycle", Journal of Transportation Technologies, 2012, 2, 1-12.