

# Ginger Harvesting Machine

Rabees U E<sup>1</sup>, Harikrishnan M<sup>2</sup>, Akhil S<sup>3</sup>, Amal Shaji<sup>4</sup>, Jithu Raju<sup>5</sup>

<sup>1</sup>Associate Professor, Department of Mechanical Engineering, VISAT, Elanji, Ernakulam, Kerala, India

<sup>2,3,4,5</sup>Student, Department of Mechanical Engineering, VISAT, Elanji, Ernakulam, Kerala, India

\*\*\*

**Abstract** - Ginger is a potential agricultural commodity to be developed in India. When the harvest comes, people still use a very simple method for harvesting ginger by using hoes, pick-axe and other farming equipments. The farmers complain for the need of so many work forces for harvesting while the labor cost is getting increased and the time spent for harvesting process is too long. Although there is an alternative of imported ginger harvesting machines, those machines are not compatible with the farming environment in India, having a high initial and maintenance cost. This machine can be used in any farming condition in India and can be prepared at village level. This machine has three main parts namely, ginger digger, screener and power transmission system. This project is focusing on design and fabrication ginger harvesting machine. The screener will not only separate ginger from soil but also not let the ginger get harmed. The screener also uses for collectible part, to make this machine need some power transmission system from the engine. This machine needs Auto front petrol engine with rotation speed 20 - 25 rpm approximately with the aid of gear reduction.

**Key Words:** Ginger, Harvesting, Labour, Farming, Equipment, Agriculture, Digger, Screener

## 1. INTRODUCTION

Ginger is a potential agricultural commodity to be developed in India. India is a leading producer of ginger in the world and during 2012-13 the country produced 7.45 lakhs tonnes of the spice from an area of 157,839 hectares. Ginger is cultivated in most of the states in India. However, states namely Karnataka, Orissa, Assam, Meghalaya, Arunachal Pradesh and Gujarat together contribute 65 percent to the country's total production. Ginger originated in Asia and now grows in several parts of the world. The root of the plant is harvested for many culinary and medicinal uses. It can be used in many forms and is edible raw as well as cooked. One of the most common uses of ginger is to relieve nausea and other gastric ailments.

A flowering plant is actually the root of the ginger plant that is harvested. A single root can have many offshoots above ground. The portion of the plant above ground has slender stalks with long leaves that come to a point. The flowers grow in clusters and are green and purple. Ginger is a tropical plant that is found in the Caribbean, India, Southeast Asia, and West Africa. Though the full name is root ginger, it is usually just called ginger.

Traditionally ginger plant is harvested manually to get the ginger out of ground. But it consumes more time and more physical exertion of worker. It is necessary to introduce machine to harvest to reduce time consumption and human efforts. A machine of this nature can be fabricated at village level application in India such as to harvest at minimum time and a minimum cost, to get ginger as quickly as possible from the field, to reduce the physical exertion, to avoid physical damage to Ginger, to reduce man power and to ensure the safety to labors.

Processing of ginger to produce dry ginger basically involves two stages-peeling of the ginger rhizomes to remove the outer skin and sun drying to a safe moisture level. Peeling serves to remove the scaly epidermis and facilitate drying. Peeling of fully matured rhizomes is done by scrapping the outer skin with bamboo splits having pointed ends and this accelerates the drying process. Deep scraping with knives should be avoided to prevent the damage of oil bearing cells which are present just below the outer skin. Excessive peeling will result in the reduction of essential oil content of the dried produce. The peeled rhizomes are washed before drying.

The dry ginger so obtained is valued for its aroma, flavor and pungency. Indian dried gingers are usually rough peeled when compared to Jamaican gingers, which are clean peeled. The rhizomes are peeled only on the flat sides and much of the skin in between the fingers remains intact. The dry ginger so produced is known as the rough peeled or unbleached ginger and bulk of the ginger produced in Kerala are of this quality.

### 1.1 Aim & Objective of the project

This project is focusing on design and fabrication ginger harvesting machine. This machine can be used in any farming condition in India and can be prepared at village level. This machine has three main parts namely, ginger digger, screener and power transmission system. The screener will not only separate ginger from soil but also not let the ginger get harmed. The screener also uses for collectible part, to make this machine need some power transmission system from the engine. This machine needs Auto front petrol engine with rotation speed 20 - 25 rpm approximately with the aid of gear reduction. Smaller and efficient combine harvesting which would be more accessible and also considerably cheaper. The mission is to create a portable, user-friendly and low cost mini harvesting machine. The idea was to create a machine

which is cheap and will reduce the labour required to harvest ginger.

### 1.2 Need of the project

Ginger was harvested by using hand, it is very difficult to harvest crop so we decide to make harvesting machine which should be economical. Most of the Indian farmer's economic condition is not good, so they not able to buy tractor or large harvesting machines, so this kind of equipment's help them to harvest in low investment. Ginger is a potential agricultural commodity to be developed in India. When the harvest comes, people still use a very simple method for harvesting ginger by using hoes, pick-axe and other farming equipments. The farmers complain for the need of so many work forces for harvesting while the labor cost is getting increased and the time spent for harvesting process is too long. Although there is an alternative of imported ginger harvesting machines, those machines are not compatible with the farming environment in India, having a high initial and maintenance cost. This machine can be used in any farming condition in India and can be prepared at village level. Because of this shortage the farmers have transitioned to using harvestings.

- Ginger harvesting needs a lot of manpower and is also very time consuming process.
- Most of the Indian farmer's economic condition is not good. Farmers in India are getting discouraged by the problems like high wages and insufficient number of labour.
- The farmers complain for the need of so many work forces for harvesting and the time spent for harvesting process is too long.

This project aims to solve all the above mentioned issues.

### 1.3 Necessity of Ginger Harvesting Machine

Ginger is one of the spices that support large number of farmers in the states of Kerala, Karnataka, Arunachal Pradesh, Orissa, West Bengal, Sikkim and Madhya Pradesh. However, Karnataka, Orissa, Assam, Meghalaya, Arunachal Pradesh and Gujarat together contribute 65 per cent of the country's total production. In Karnataka, the ginger production was 0.019 million tonnes from an area of 0.0524 million ha, with an average productivity of 2.80 tonnes per headmost of the farmers are having below 2 hectares so they not using tractor for harvesting ginger. They using daily wages peoples for harvesting it required more energy to harvest ginger from field. Due to harvesting using daily wages people, wages for harvesting is accurse more it affect their profit. Harvesting is one of main important operation in ginger cultivation. In India, it is performed by manual method with the help of hand tools i.e., special fork type of spade/ pick axe, bullock drawn and power operated devices and by using traditional diggers drawn by tractors or power tillers. It was found that there is a noticeable damage to the crop during harvesting. The mechanization of ginger

harvesting is need of the hour as it saves harvesting time, cost of harvesting, crop damage and reduce drudgery involved. Keeping in view of the above points in mind, the present study was undertaken with the objective of development and performance evaluation of ginger harvesting machine.

### 1.3 Ginger Cultivation in India

It has been used as a spice and medicine in India and China since ancient times. It was the first oriental spice known in Europe and having been obtained by the Greeks and Romans from Arab traders, who kept a secret of their origin of the spice in India. In India, it is grown in the states like Kerala, North States, Sikkim, HimachalPradesh, Odisha, West Bengal, Karrnataka, AndhraPradesh and Maharashtra.

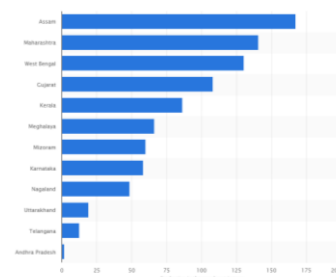

Chart -1: Ginger Cultivation in India

## 2. LITERATURE REVIEW

[1] M. R. Sanjay, G. R. Arpitha, L. Laxmana Naik, B. Yogesha Department of Mechanical Engineering, Malnad College of Engineering, Hassan, India (World Journal of Engineering and Technology, 2015, 3, 320-338) Design and Fabrication of Ginger Harvesting Machine. In this journal the forces required for harvesting the ginger by using this machine are calculated. Also it compare the labour work while using the machine instead of manual harvesting.

[2] Dr. P.K.Sharma, S.V.Kasar, Mechanical Department, NIIST, Bhopal (International Journal of Advance Engineering and Research Development Volume 3, Issue 12, December -2016) This paper has set out a vision of how aspects of harvesting, crop production could be automated in the future. Although existing manned operations can be efficient over large areas there is a potential for decreasing the scale of treatments with self-directed machines that may result in even superior efficiencies.

[3] Dr. C.N.Sakhale, Prof. S.N.Waghmare, Rashmi S.Chimote (Associate Prof., Dept. of Mechanical Engg. Priyadarshini College of Engineering, Nagpur, MH- India) Concept to design a project for small scale farmers. And in one machine multi functions can be performed with cheap cost as compared to other agriculture machine. For this concept not essential to skilled person. Mechanism of the machine should be very simple. so, that for gardening and small scale farming, design this concept.

[4] Pradip S. Gunavant, Sarfraj J. Mulani, Vishal N. Gandhe, Gurunath Shinde, Vinayak D Yadav Assistant Professor,

Mechanical Engineering Department, Maharashtra, India. (International Advanced Research Journal in Science, Engineering and Technology, Vol. 4, Special Issue 1, January 2017) Here in this study efforts are taken to design and develop a seed planting machine which is suitable for ridge and furrow method and also plant the seed at specific distance with specific quantity and reduce the requirement of seed per unit area.

[5] Dighole Tukaram Nagorao, Khade Satish Ramchandra, Kumbhar Prashant Rajendra (Assistant Professor, Maharashtra, India) Development of Ginger Sowing Machine The designed ginger sowing transplanter is motor operated machine developed for sowing ginger or some other seeds in the furrows

### 3. METHODS OF GINGER HARVESTING

#### 3.1 Manual Harvesting

This is the traditional method of harvesting ginger using a hoe, cutlass or mattock to dig round the standing stem to pull out the root before detaching the uprooted roots from the base of the plant. Ginger plant preparing for harvesting within eight months from the date of planting. Brown leaves are ready to be harvested at arrival points to the bottom-up dries. This condition should be harvested in order to extract the ginger oil. The leaves are harvested in the dry state by seed tuber used. Harvested ginger, removed from the dried leaves, roots, and tubers, unearthed by the adhering soil is removed, washed with water and dried in shade. The ginger used as vegetable and cooking, it should be harvested from the fifth month after sowing.



Fig.3.1-Manual harvesting method

#### 3.2 Mechanical Harvsing

Before going to design a harvesting machine, it is necessary to know the force required to dig/penetrate the ginger bed and get ginger. The set up was fabricated as per the drawing shown in Figure. The blades are similar to pick-axe in construction, and then fabrication was carried out. The legs i.e. structural support were placed along the bed in such way that the bed has to come exactly at middle of the legs. By using the machine the blades are penetrate the bed and pull out the ginger from the bed. Instead of using pick-axe like equipment for each ginger plant the blades fitted around the rotating shaft pulled out continuously from the bed.

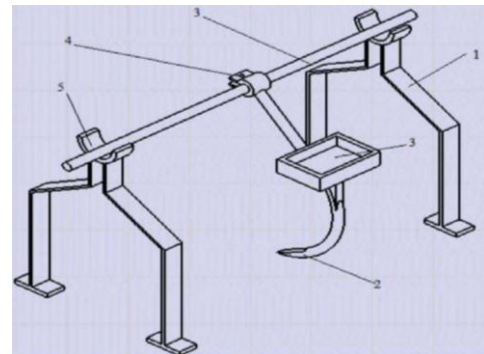

Fig.3.2 -Mechanical ginger Harvesting

The farmers complain for the need of so many work forces for harvesting while the labor cost is getting increased and the time spent for harvesting process is too long. Although there is an alternative of imported ginger harvesting machines, those machines are not compatible with the farming environment in India, having a high initial and maintenance cost. This machine can be used in any farming condition in India and can be prepared at village level.

### 4. METHODOLOGY

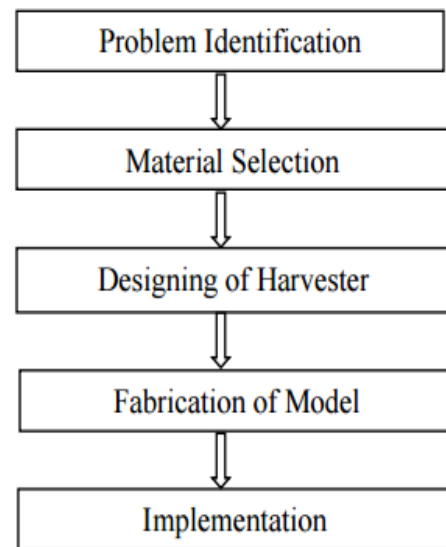

Chart 4.1- Methodology

#### 4.1 Problem Identification

- It was very difficult to remove the soil and pull out the ginger.
- More human labour is required for harvesting
- There is shortage of skilled labour available agricultural purpose
- Shortage of farmers has transitioned to using harvesting crop manually using labour but this method is very time consuming.
- Harvesting of ginger manually requires more effort.



## 4.2 Material Selection

SL. NO	COMPONENTS	MATERIAL
1.	Chassis	Mild Steel
2.	Wheel	P V C
3.	Bearing	Steel
4.	Shaft & blades	Mild Steel
5.	Pulley	Mild Steel
6.	Belt	Leather

Table.4.2 - Material Selection

## 5. COMPONENTS AND DESCRIPTION

The major components that are used in the project are ,

### 5.1. Chassis

The whole power is mounted on Chassis structure with suitable arrangements. Frame is made of C channel .Chassis is the creation of metal structures by cutting, bending, and welding processes. Chassis is a value added process involving creation of machine parts and structures from various raw materials. Mild steel is type of carbon steel with low amount of carbon, it is also known as “low carbon steel” although ranges vary depending on source, the amount of carbon typically found in mild steel is 0.05% to 0.25% by weight. Whereas higher ranges from 0.30% to 2.0%. Mild steel is not an alloy steel and therefore does not contain large amount of other elements beside iron.

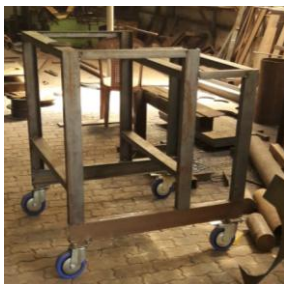

Fig 5.1- Chassis

### 5.2. Engine

The internal combustion engine is an engine in which the combustion of a fuel (generally, fossil fuel) occurs with an oxidizer (usually air) in a combustion chamber. In an internal combustion engine the expansion of the high temperature and high pressure gases, which are produced by the combustion, directly applies force to components of the engine, such as the pistons or turbine blades or a nozzle, and by moving it over a distance, generates mechanical work. Given that the majority of engines for which a speed is defined rotate, engine speed is measured in revolutions per minute (RPM). Engines may be classified as low-speed,

medium-speed or high-speed, but these terms are always relative and depend on the type of engine being described.



Fig.5.2-Engine

### 5.3. Wheel

A wheel is a circular component that is intended to rotate on an axial bearing. Wheels, in conjunction with axles, allow heavy objects to be moved easily facilitating movement or transportation while supporting a load, or performing labor in machines. Wheel is designed and fabricate inspired from the wheels of tractors for the usage on loose soils and other unlevelled surface.



Fig.5.3 - Wheel

### 5.4. Bearing

A bearing is machine element that constrains relative motion to only desired motion and reduces friction between moving parts. The bearings are pressed smoothly to fit into the shafts because if hammered the bearing may develop cracks. Bearing is made up of steel material and bearing cap is mild steel. Some types of bearings are roller bearing and ball bearing. The bearings are mainly used to reduce friction. The allow demand application to meet maximum efficiency, reliability, durability and performance. A ball bearing is a type of rolling element bearing that uses balls to maintain the separation between bearing races. The purpose of ball bearing is to reduce rotational friction and support radial and axial loads. It achieves this by using atleast three races to contain the balls and transmit loads through the balls. The most application one race is stationary and other is attached to rotating assembly. As one of the bearing races rotates it cause the balls to rotate as well. Because the balls are rolling they have a much lower coefficient of friction than if two flat surfaces where sliding against each other



Fig 5.4- Bearing

### 5.5 Shaft

Shaft is a common machine element which is used to transmit rotary motion or torque. It generally has circular cross-section and can be solid or hollow. Shafts are supported on the bearings and transmit torque with the help of gears, belts and pulleys etc. Shafts are generally subjected to bending moment, torsion and axial force or a combination of these three. So the shafts are designed depending upon the combination of loads it is subjected to. Spindle stub and axle are some important types of shaft. Small shaft is called spindle. Shaft integral part of the prime mover is called stub shaft. An axle is a non-rotating member that carries no torque and is used to support rotating wheels, pulleys etc. And therefore is subjected to bending moment only. Hot-rolled plain carbon steel is the least expensive material used for shafts. These essentially require machining to remove the scales of hot rolling process. Cold rolled plain carbon steel provides better yield strength and endurance strength but the cold working induces residual stresses. Surface is smooth in this case and amount of machining therefore is minimal. It is used for general purpose transmission shafts.



Fig 5.5- Shaft

### 5.6. Pulley

A pulley is a wheel on an axle or shaft that is designed to support movement and change of direction of a taut cable or belt, or transfer of power between the shaft and cable or belt. In the case of a pulley supported by a frame or shell that does not transfer power to a shaft, but is used to guide the cable or exert a force, the supporting shell is called a block, and the pulley may be called a sheave. A pulley may have a groove or grooves between flanges around its circumference to locate the cable or belt. The drive element of a pulley

system can be a rope, cable, belt, or chain. V-belt pulleys are solely used for transmitting power between two parallel axels. The most notable difference between a v-belt pulley and other types of pulleys (round belt, flat, etc.) would be the geometry of the groove or grooves located around the circumference of the pulley; these grooves guide and gain traction on a v-belt.



Fig 5.6 – Pulley

### 5.7. Blades

. Blades are typically made from materials that are harder than those they are to be used on. Historically, humans have made blades from flaking stones such as flint or obsidian, and from various metal such as copper, bronze and iron. Modern blades are often made of steel or ceramic. Blades are one of humanity's oldest tools, and continue to be used for combat, food preparation, and other purposes. Blades work by concentrating force on the cutting edge. Certain blades, such as those used on bread knives or saws, are serrated, further concentrating force on the point of each tooth



Fig 5.7- Blades

### 5.8. Battery

A battery is a device consisting of one or more electrochemical cells with external connections for powering electrical devices such as flashlights, mobile phones, and electric cars. When a battery is supplying electric power, its positive terminal is the cathode and its negative terminal is the anode. The terminal marked negative is the source of electrons that will flow through an external electric circuit to the positive terminal. When a battery is connected to an external electric load, a redox reaction converts high-energy reactants to lower-energy products, and the free-energy

difference is delivered to the external circuit as electrical energy.



Fig 5.8 – Battery

### 5.9. Starter motor

A starter (also self-starter, cranking motor, or starter motor) is a device used to rotate (crank) an internal-combustion engine so as to initiate the engine's operation under its own power. Starters can be electric, pneumatic, or hydraulic. In the case of very large engines, the starter can even be another internal-combustion engine. Internal combustion engines are feedback systems, which, once started, rely on the inertia from each cycle to initiate the next cycle. In a four-stroke engine, the third stroke releases energy from the fuel, powering the fourth (exhaust) stroke and also the first two (intake, compression) strokes of the next cycle, as well as powering the engine's external load. To start the first cycle at the beginning of any particular session, the first two strokes must be powered in some other way than from the engine itself. The starter motor is used for this purpose and it is not required once the engine starts running and its feedback loop becomes self-sustaining.



Fig 5.9 – Starter motor

### 5.10. Belt

A belt is a loop of flexible material used to link two or more rotating shafts mechanically, most often parallel. Belts may be used as a source of motion, to transmit power efficiently or to track relative movement. Belts are looped over pulleys and may have a twist between the pulleys, and the shafts need not be parallel. In a two pulley system, the belt can either drive the pulleys normally in one direction (the same if on parallel shafts), or the belt may be crossed, so that the direction of the driven shaft is reversed (the opposite direction to the driver if on parallel shafts). As a source of

motion, a conveyor belt is one application where the belt is adapted to carry a load continuously between two points. The belt drive can also be used to change the speed of rotation, either up or down, by using different sized pulleys.



Fig 5.10 – Belt

## 6. WORKING PRINCIPLES

- The ultimate aim of the machine is to harvest ginger without any left overs underneath and make the process easy.
- The initial design consists of a six legged structure, with a basement and wheels attached to each leg.
- At the one side of the chassis, there is an engine is mounted and is powered by petrol fuel.
- By switch ON the self motor of the engine , the engine starts.
- An accelerator cable is provided for locking the engine at at a rated speed or RPM.
- On the other side of the chassis, a solid shaft having 8 number of blades over the shaft is mounted by using two ball bearings.
- One end of the shaft is fitted with V pulley, which is connected by using appropriate V belt to the engine output pulley.
- A fuel tank is provided above the engine for the fuel supply by gravity.
- The engine rotates on a rated rpm, the drive shaft rotate on a slow rpm for harvesting.
- The drive shaft get slow speed by using gear ratio.
- By rotating the drive shaft, the blades penetrates the soil of the ginger bed.
- The soil loosens and the blades pulled out the ginger from the bed
- As per alignment position of the shaft the harvested ginger is throw out on the sides of the moving machine.
- Fiber castor wheels provided for the smooth movement of the machine along the sides of the bed.
- This process is carried out for harvesting ginger using this machine.





- Maximum Torque 6 Nm @ 4,000 rpm

### 8.2 Self starting motor

- Motor type DC Supply
- Volt 12 V
- Ampere 50A
- Speed 500 rpm

### 8.3 Ball bearing

- Item 6004RS
- Type Deep Groove
- Material Chrome Steel
- Closures Rubber Seals
- ID (inner diameter) 20mm
- OD (outer diameter) 42mm
- Size 20 x 42 x 12 mm
- Lubrication Self Lubricated (Grease)

### 8.4 Belt Pulley

- Standard V belt pulley
- No of grooves 1
- Outer dia 10 inch
- Bore type Fixed bore
- Bore dia ¾ inch
- Material cast iron
- Pitch 4L or A type
- Keyway size 0.187 inch

### 8.5 Belt

- Type A
- Thickness ½ inch
- Depth 5/16 inch
- Length 52 inch
- Bevel 40 degree
- Material Rubber filled polyester
- Application light duty

### 8.6 Battery

- Type Li- ion battery
- Volt 12 V DC
- Ampere 5 A
- Rechargeable yes

## 9. CALCULATION

The various calculations are done for selecting the parts for fabricating the ginger harvesting machines are done, and are shown below.

### 9.1 Calculation of engine power

Experiments are done on the field around one meter by harvesting the ginger by the hand operated machine as

shown earlier. So we concluded that minimum of 20 upto 50 kg weight is required for dig out the same.

Considering the maximum average force to dig out the ginger from the bed, 35 Kg

$$F = 35 \text{ kg}$$

$$F = 35 * 9.81 = 343.5 \text{ N}$$

$$\text{TORQUE} = \text{FORCE} * \text{DISPLACEMENT}$$

$$= 343.5 * 0.35$$

$$(\text{length of the blade} = 350 \text{ mm})$$

$$= 120.17 \text{ Nm}$$

$$\text{Speed} = 60 \text{ rpm}$$

$$\text{Torque} = 120.17 \text{ Nm}$$

$$\text{Power} = (2 * 3.14 * 60 * 120.17 * 1000 * 1.5) / 60$$

$$= 1132.57 \text{ W}$$

$$= 1.13 \text{ Kw}$$

Hense 97 cc engine is selected.

### 9.2. Calculation of gear ratio

Diameter of driven pulley,  $d_1 = 4$  inches

Diameter of drive pulley,  $d_2 = 10$  inches

Required speed on drive pulley  $N_2 = 100$  rpm

$$\frac{\text{Speed of driven pulley}}{\text{Speed of driving pulley}} = \frac{\text{Dia of driving pulley}}{\text{Dia of driven pulley}}$$

$$N_1 / N_2 = d_2 / d_1$$

$$\text{Engine speed (speed of driven pulley), } N_1 =$$

$$N_1 = (N_2 * d_2) / d_1 = (100 * 10) / 4 = 250 \text{ rpm}$$

### 9.3 Calculation of ball bearing

Selection of Bearing No. 6004RS

Outer Diameter of Bearing (D) = 42 mm

Thickness of Bearing (B) = 12 mm

Inner Diameter of the Bearing (d) = 20 mm

Maximum Speed = 15,000 rpm

Mean Diameter (dm) = (D + d) / 2

$$= (42 + 20) / 2 = 31 \text{ mm}$$

## 10. FABRICATION PROCESS

- Measuring and marking the C-channel made of mild steel as per the design by using measuring tape.
- Using power hacksaw cutting the material for manufacturing the chassis.
- 2 pieces of 1000 mm length of 4 inch standard size for the foundation.
- 4 pieces of 900 mm length and 2 pieces of 700 mm length are cut for the pillars.
- 5 pieces of 800 mm length are cut for connecting the pillars.
- Joining the cut pieces of c channel by using MIG welding as per the design.



- 300 mm diameter round MS shaft is cutted for 850 mm length.
- On lathe the shaft is cut for step of 20 mm diameter on two ends for 15 mm length
- Blades are made by using gas cutter as per the design and dimensions from 3mm thick flat sheet.
- The blades are fixed over the shaft by welding as per the design.
- The pulley which is purchased of 10 inch diameter is fixed on one end of the drive shaft.
- Already purchased fibre castor wheels are mounted on the chassis by using nuts and bolts.
- The petrol fuel engine and its accessories are mounted on the chassis as per the design by using nuts and bolts.
- Also provide rectangular slots for adjusting the engine position.
- Suitable V belt of appropriate length is provide for the power transmission from the engine shaft to dive shaft.
- The fuel tank are provided at a height for obtaining the gravitational flow of the fuel to the carburater.
- Key switches, accelerator liver, and the ignition switches are provided on the panel at the hand rest.

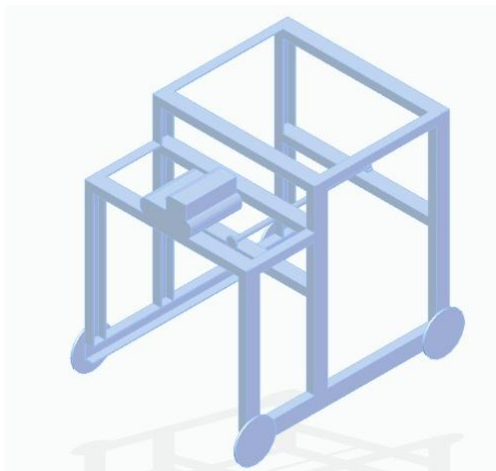

Fig : 8 .1- 3D Model

### 11. ADVANTAGES

- Manual power not required
- Maintenance is easy
- Separate tapioca from soil and collect in ridge, easy to load.
- Replacement of parts is easy the involvement of manual work is highly negligible.
- Simple in construction.
- High efficiency
- No need of skilled operators to operate this system.

### 12. APPLICATIONS

- It is used in the agricultural fields.
- It is used in ground seed harvesting
- Arm can be used for up lifting heavier objects  
Replacement of parts is easy

### 13. BENEFITS

- Less energy expended.
- Increase in the number of Cassava roots uprooted.
- Saving time.
- Reduction in the risk of health hazards of developing blisters in the palms, callus palms, arched spinal cord and waste pains over time.
- Higher output and productivity.

### 14. RESULT

After complete the machine, it was taken into agricultural field and test the entire performance of the equipment. The experiment had been done at a ginger field-Kakkoor, Thirumarady Gramapanchayath, Ernakulam district. During this experiment 100 mtr bed were harvested by using manual method and same were harvested by using the ginger harvesting machine. It has been observed that:

Manual Method	Ginger Harvesting Machine
During harvesting 20% waste occurs that means some part of the ginger remains in the soil.	During harvesting 5% waste occur that means we can completely pullout the ginger without any damage.
More time consuming process.	Less time consuming.
High man power required.	Less man power required.
High labour cost required, skilled labours required.	Less labour cost, i.e. the field owner can be harvesting using this product without depend on labours, no skill required.

Chart 14: Result observed by comparing with manual harvesting method

### 15. CONCLUSION AND FUTURE WORK

The idea was to create a machine which is cheap and will reduce the labour required to harvest crops. This machine has the capability and the economic value for fulfilling the needs of farmers having small land holdings. Comparisons are made between manual and machine harvesting. At present day ginger is harvested manually with the aid of labors, they demand Rs 100 per 60 kg of ginger. The performance of the harvester is evaluated in the field. The cost of the machine is about Rs. 26,000/- and if the farmer

buys this machine, he or she can recover the invested money back by harvesting two and half acres (approx.). It is quite simple in design and fabrication, so it can be fabricated at village level. By adapting this machine, problems of the labor crises can be reduced, when compared to manual harvesting with only 18% of labors being required. It makes the process faster than manual harvesting and hence reduces most of the harvesting time and labors required to operate the machine; thereby, it reduces the labor cost. The machine can be used by a maximum number of farmers; definitely farmer can overcome the labor crisis problem. The productivity can also be increased.

This study leaves a wide scope for future investigations. In future it can be automated through tractors with the aid of PTO (Power Take Off) shaft. Collector can be used for collecting the ginger. The future work for this design by providing better c bracket or gripper for lifting heavier objects. It is used in ground seed harvesting. The device is recommended to the ginger growing farmers to enhance and enjoy the benefits.

The future work for this design by providing blades made up of non metals for lifting the ginger without any harm effect to the products. By using a better speed engine and better bearings we can use the machine as a tiller on small scale productions. By providing a screener on the bottom portion of the machine with a suitable vibrator we can separate the ginger and ginger like products such as turmeric from the soil without any human interruption. With a suitable fiber blades used in the machines for cutting the grass in the garden provided at the front position of the harvesting machine, we can cut the grass portions from the ginger and thus enables the machine to dig out the ginger from the soil very easily. This machines are also concentrates on the medium scale production with minimum human efforts, with affordable price for the farmers.

## REFERENCES

- [1] Design and Fabrication of Ginger Harvesting Machine , Article in World Journal of Engineering and Technology - January 2015
- [2] Development of Ginger Sowing Machine , Article in India International Journal of Innovative Research in Science, Engineering and Technology Vol. 7, Issue 4, April 2018
- [3] Review paper on crop harvesting machine ,article in International Journal of Advance Engineering and Research Development Volume 3, Issue 12, December - 2016
- [4] A Review Paper on multi purpose farming machine, article in International Research Journal of Engineering and Technology (IRJET) Volume: 03 Issue: 09 | Sep-2016
- [5] Design of Machine Elements by V. B. Bhandary, Third Edition, McGraw Hill Education Pvt. Ltd.
- [6] A Textbook of Machine Design by R. S. Khurmi and J. K. Gupta S. Chand Publications
- [7] A textbook of Strength of Materials by Dr. R. K. Bansal, fifth Edition, Laxmi Publication Pvt. Ltd.
- [8] Sprocket Catalogue, Power Transmission Components Division, U.S. Tsubaki, Inc.
- [9] Farm Mechanization by using Seed Planting Machine, article in International Advanced Research Journal in Science, Engineering and Technology ,Vol. 4, Special Issue 1, January 2017
- [10] Smart Turmeric Harvester, article in International Journal of Recent Technology and Engineering (IJRTE), Volume-8, Issue-4, November 2019