

# PARKING SLOT AVAILABILITY CHECK AND SYSTEM OVER IoT(Internet of Things)

BANDARU SUMANTH<sup>1</sup>, LAXMI APURVA THUNGATHURTHY<sup>2</sup>

<sup>1</sup>BE, Dept. - EXTC, BHARATI VIDYAPEETH COLLEGE OF ENGINEERING, Mumbai

<sup>2</sup>BSc, Dept. - IT, AMITY UNIVERSITY ONLINE, Noida

\*\*\*

**Abstract:** Nowadays in lots of multiplex structures, there may be a severe hassle for vehicle parking. There are many slots available for car parking. For an individual to park a car, he/she has to look for all the lanes. Moreover, there is a need of manual labour concerned for this technique for which there's a lot of investment. So, the want is to develop a device which indicates at once which parking slot is vacant in any lane. The assignment includes a device inclusive of infrared transmitter and receiver in each lane. So, the person getting into a parking region can view the usage of IoT module concerned and can decide which slot to enter in an effort to park the automobile. Conventionally, automobile parking structures do not have any sensible monitoring device. Parking slots are monitored by the way of human beings. All cars enter into the parking area and time is consumed in trying to find a parking slot. Sometimes it creates blockage. Conditions end up to worsen when there are a couple of parking lanes and each lane has more than one parking slot. Use of automatic system for automobile parking monitoring will lessen the human efforts and proportionally lessen the time consumed. Here, we're making a use of IR sensors to discover the car in that parking slot. So, if it's far occupied then data is available within the net and free slots also are shown so that one could e-book the slot before coming by the usage of IoT. This is to avoid waiting and lessen the time consumed. We are using Microcontroller and IoT module which are interfaced together to view the slots using net. This project uses regulated 5V, 500mA power deliver. Unregulated 12V DC is used for relay. 7805 three terminal voltage regulator is used for voltage regulation. Bridge type complete wave rectifier is used to rectify the AC output of secondary of 230/12V step down transformer.

**Keywords:** IoT, IR-sensors, Arduino Uno, webpage, ESP8266

## 1. INTRODUCTION

The idea of Internet of Things (IoT) begun with things which have character specialized devices. The gadgets may be accompanied, managed or located by utilizing far flung PC's related through Internet. IoT augments the usage of Internet giving the correspondence, and consequently among device of the devices and bodily articles, or Things. The two unmistakable words in IoT are internet and Things. Internet implies a huge global

gadget of related servers, PCs, pills and mobiles making use of the universally utilized conventions and interfacing frameworks. Internet empowers sending, accepting, or conveying of data. Thing in English has quantity of employments and implications. IoT in preferred comprises of device of the devices and physical objects, variety of gadgets can gather the information at faraway regions and bring to gadgets overseeing, purchasing, finding out and breaking down the facts in the methods and administrations. It gives a dream wherein things (wearable, watch, caution clock, domestic devices, encompassing items) land up exceedingly savvy also, act alive via detecting, figuring and conveying through installed little gadgets which interface with far flung articles or people through community. The quintessential of making a Smart City is presently attending to be in IoT. It seems that viable with the upward thrust of the Internet of Things. One of the important problems that keen urban areas pick out are vehicle stopping places of work and interest administration frameworks. In current city, areas locating a reachable parking space is constantly difficult for drivers, and it has an inclination to land up plainly more difficult with progressively expanding range of personal vehicle customers. This situation may be viewed as an open door for smart city regions to strive activities all together enhance the productiveness of their stopping assets along these lines prompt to lessening in looking for instances, motion blockage and road mishaps. Issues referring to stopping and activity clog may be illuminated if the drivers can be knowledgeable in advance of time about the accessibility of parking spots at and round their deliberate vacation spot. Recent progresses in making minimum effort, low-manipulate established frameworks are assisting engineers to assemble new programs for Internet of Things. Taken after by the way of the improvements in sensor innovation, severe modern urban groups have picked conveying distinctive IoT based totally frameworks in and around the city regions with the stop purpose of checking. A cutting-edge observe carried out via the International Parking Institute mirrors an expansion in quantity of innovative mind diagnosed with stopping frameworks. At first, there are positive preventing systems that claim to topics of conveying continuous statistics approximately handy parking spots. Such frameworks require talented sensors to be sent inside the preventing areas for checking the inhabitance and similarly brisk records coping with devices

preserving in thoughts the stop purpose to increase down to earth bits of understanding from information amassed over exclusive resources.

## 2. RELATED WORK

### 2.1 Proposed System

IR Sensor is to detect whether any vehicle is placed in the slot or not. Arduino takes all sensors values and gives to the Wi-Fi module. Wi-Fi Modules gets the string data, these data values are posted in the server. Thingspeak / cloud server gets the data from the system and plots the values in a graph.

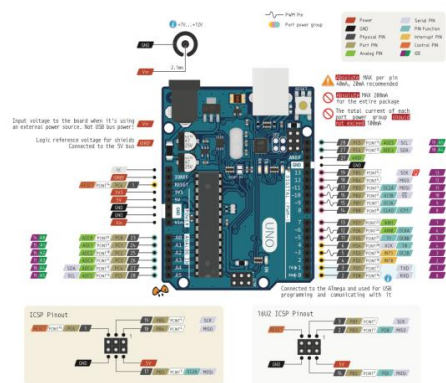


Fig-3 Arduino Microcontroller

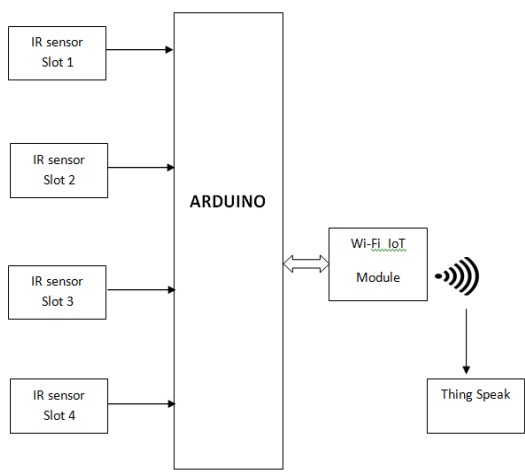


Fig-1 Block Diagram

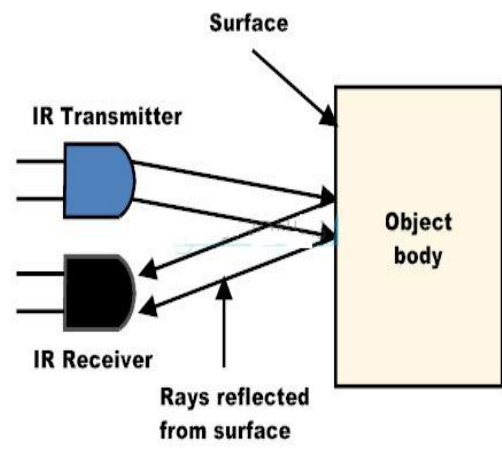


Fig-4 IR Sensor

## 3. IMPLEMENTATION

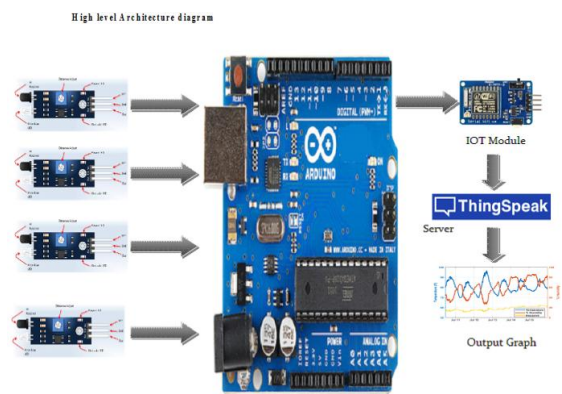


Fig-2 System Architecture

**3.1 IR Sensor:** In a Parking slot, we will use this sensor to detect whether any vehicle is placed in that slot or not, detected values are given to the Arduino.



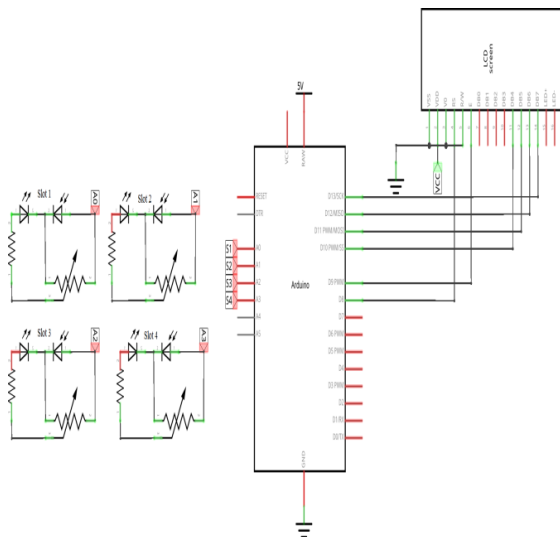
Fig-5 Wi-Fi Module

**3.2 Wi-Fi Module:** The data from controller is send to server using Wi-Fi module.

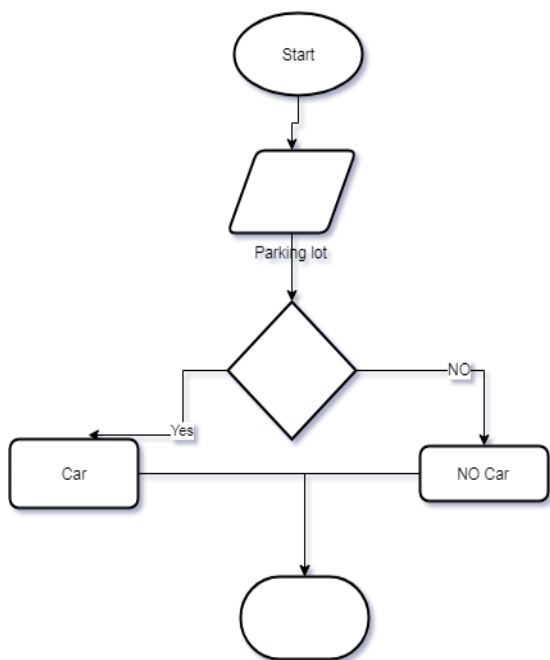
### 3.3 ThingSpeak/Cloud Server

The data from the parking slot is stored in the web page of thingspeak. The values stored are plotted in a graph. ThingSpeak is an open source Internet of Things (IoT)

application and API to store and retrieve data from things using the HTTP protocol over the Internet or via a Local Area Network(LAN). ThingSpeak enables the creation of sensor logging applications.

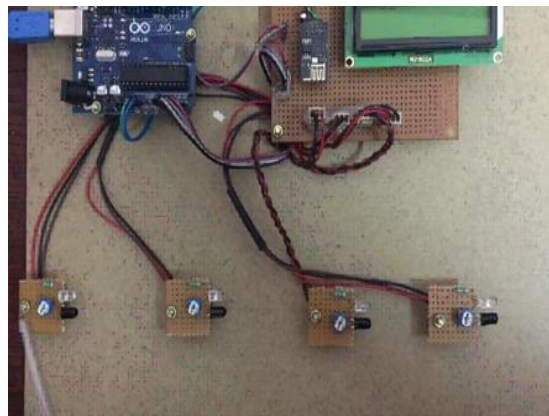


**Fig:-5 Circuit diagram**



**Fig:-6 Flow Chart of the application**

#### 4. EXPERIMENTAL RESULTS



**Fig:-7 Hardware Demo**

#### Parking Slot Monitoring Over IOT



**Fig:-8 Empty Parking Slots**

#### Parking Slot Monitoring Over IOT



**Fig:-9 Two Slots filed with cars**

#### 5. CONCLUSION

The thought of Smart Cities have dependably been a fantasy for humankind. Since the recent years big headways have been made in making wise city areas a reality. The development of Internet of Things and Cloud improvements have provided ascent to new possible results as far as savvy city areas. Savvy stopping offices and pastime management frameworks have dependably

been at the center of constructing wise urban communities. In this paper, we cope with the issue of stopping and gift an IoT based totally Cloud coordinated excellent preventing framework. The framework that we advocate offers regular information with recognize to accessibility of stopping openings in a stopping quarter

## 6. REFERENCES

- [1] Marian Look, "Trash Plant: India", earth911B.
- [2] Basic Feature, "Solid waste Management Project by MCGM".
- [3] Microtronics Technologies, "GSM based garbage and waste collectionbins overflow indicator", September 2013.
- [4] Hindustan Embedded System, "City Garbage collection indicator using RF (ZigBee) and GSM technology".
- [5] Z embedded, "GSM modem interfacing with 8051 for SMS" August2012  
<https://thingspeak.com>
- [6] <https://www.arduino.cc/en/Main/Software/>
- [7] Rico, J., Sancho, J., Cendon, B., & Camus, M. (2013, March). Parking easier by using context information of a smart city and hence enabling fast search and management of parking resources.