

Smart Garbage Monitoring System using NodeMCU

Aayush *, Rohit Jaiswal*, R.Satyateja*, Prof. S.P.Dash**

*Student at Dept. of Electronics & Telecommunication, BVCOE, Pune

**Professor at Dept. of Electronics & Telecommunication, BVCOE, Pune

Abstract- In this day and age, for a nation to be created they ought to have brilliant frameworks for advancement. This paper turns out with a brilliant answer to guarantee absolute consistency of garbage. The paper raised the worry that the garbage canister at open spots gets flooded well ahead of time before the beginning of the following cleaning process which prompts different dangers, for example, awful smell and grotesqueness to that spot which might be the underlying driver for the spread of different respiratory ailments. To keep away from all such risky situations and keep up open neatness and wellbeing this work is mounted on savvy trash observing framework.

Index Terms- NodeMCU, Ultrasonic sensor, GPS Module

I. INTRODUCTION

A healthy environment is necessary if you want to stay healthy. Regardless of the way that the world is in the period of upgradation, there is one more issue that must be overseen which is "Garbage". This offers ascend to different maladies as countless creepy crawlies and mosquitoes breed on it. In India the nonappearance of proficient waste administration has prompted some difficult issues, it is a major test looked by the greater part of the locales of India. Which can annihilate the issue or can decrease it to the base level. We frequently observe garbage bins being filled over and additional waste materials being disposed and accumulated around the bin in different cities. Those improperly disposed garbage will be the dwelling for various number of dangerous micro-organisms, insects and mosquitoes to breed on.

Because of this, severe and contagious disease is stimulated and also bad smell comes out of it and may cause illness to human beings. The region of most urban communities has strived its best to mitigate this issue by giving a few trash receptacles all through the town.

In any case, it is a manual approach and various trucks from the municipal authority are sent to the waste canisters to gather the waste. The garbage are stacked to the truck and passed on to the pre-indicated areas. Along these lines, the people associated with gathering and shipping the garbage are normally not dependable enough to make the activity very much done. Most of the time garbage are not collected from each and every waste bin properly due to municipal authorities did not have information about the garbage bin. The manual waste collection and management approach has

problems such as lack of information about the collecting time and place.

Generally, there is lack of proper monitoring system to follow all activities related to waste management and lack of smart monitoring of the condition of the bin.

This proposed project shows effective solution to manage the garbage. This garbage monitor is implemented using sensors and NodeMCU microcontroller.

The details of each dustbin are monitored by the municipal authorities. The usage of a trash observing system utilizing sensors, microcontrollers and GSM module ensures the cleaning of dustbins soon when the refuse level shows up at its most prominent. This framework likewise assists with checking the fake reports and subsequently can decrease corruption in the general administration framework.

II. EXISTING SYSTEM

In the current framework, trash is gathered by the authorities by week after week once or by 2 days once. In spite of the fact that the trash floods the trash container and spread over the streets and dirties the earth. The smell will be overwhelming and delivers air contamination and spreads diseases. The road dogs eat the waste nourishment and spread over the region and make the environment dirty so we are wanting to plan Garbage Management for Smart Cities.

III. PROPOSED SYSTEM

The proposed framework effectively screens the degree of the

Trashcan utilizing the ultrasonic sensor as demonstrated the figure 1.

The NodeMCU unit is utilized to interface all the data gathered from the ultrasonic sensor and the site page.

In this manner, with the above guide now the authorities can

Monitor the level of the trash in the trashcan and Empty the junk jars when they are full, destroying the Dangerous issues and guaranteeing a clean environment.

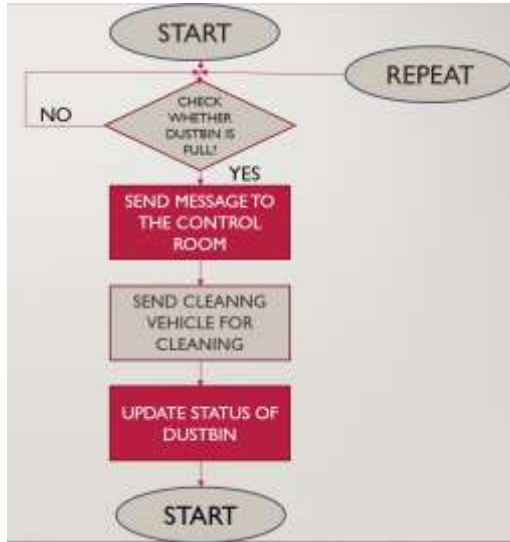

Figure 1: Flowchart of the system



Figure 3: Ultrasonic Sensor

Pin Number	Pin Name	Description
1	Vcc	The Vcc pin powers the sensor, typically with +5V
2	Trigger	Trigger pin is an Input pin. This pin has to be kept high for 10us to initialize measurement by sending Ultrasonic wave.
3	Echo	Echo pin is an Output pin. This pin goes high for a period of time which will be equal to the time taken for the Ultrasonic wave to return back to the sensor.
4	Ground	This pin is connected to the Ground.

3.1 Node MCU (ESP8266 Wi-Fi Soc) and Its Configuration

NodeMCU is an open source development board and firmware based in the widely used ESP8266 -12E Wi-Fi module. It allows you to program the ESP8266 Wi-Fi module with the simple and powerful LUA programming language.

3.1.1 Pin Configurations

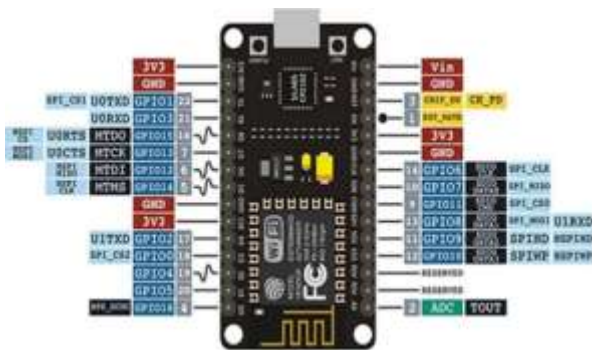

Figure 2: Pin Configuration of NodeMCU

3.3 Connecting Node MCU (ESP8266) with

Ultrasonic Sensor

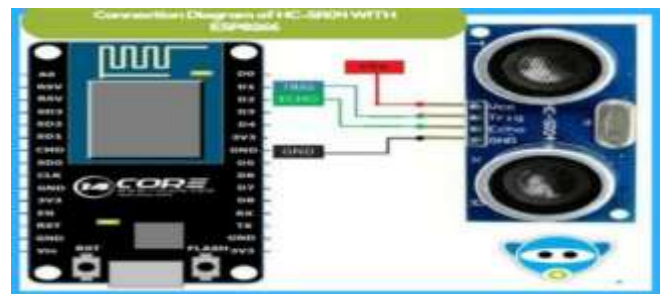

Figure 4. Connecting Sensor to NodeMCU

3.2 Ultra Sonic Sensor

The Ultrasonic Sensor is utilized to gauge the separation with high precision and stable readings. It can gauge the good ways from 2 cm to 400 cm or from 1 inch to 13 feet. It radiates an ultrasound wave at the recurrence of 40 KHz noticeable all around and on the off chance that the article will come in its manner, at that point it will skip back to the sensor. By utilizing that time which it takes to strike the item and returns, you can ascertain the separation.

3.4 Arduino Integrated Development Environment

The Arduino Integrated Development Environment – or Arduino software (IDE) contains a text editor for writing code, a message area, a text console, a toolbar with buttons for common functions and a series of menus. It connects to the Arduino hardware to upload programs and communicate with them. The NodeMCU board interfaces with the Arduino Development Environment (IDE). The client composes the code in the IDE, at that point transfers it to the board which

executes the code, cooperating with information sources and yields, for example, sensors, engines, and lights.

3.5 NEO-6MV2 GPS Module

The NEO-6MV2 is a GPS (Global Positioning System) module and is used for navigation. The module basically checks its location on earth and provides yield information which is longitude and latitude of its position. It has an active antenna integrated with built in EEPROM used to save data.



Figure 5: NEO-6MV2 GPS Module

IV. STIMULATION

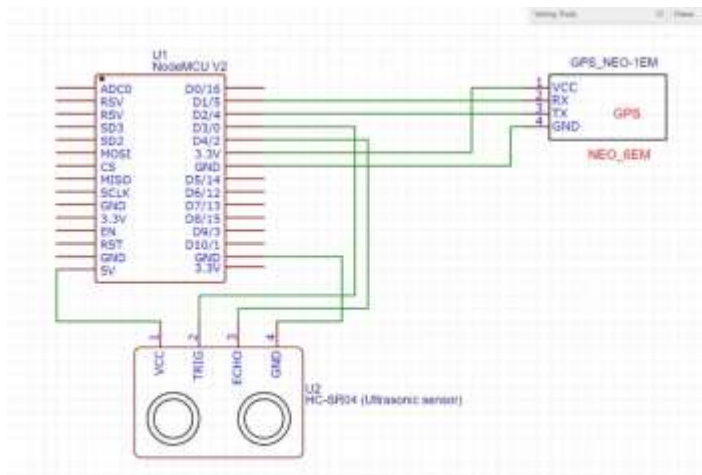

Figure 6: Stimulation circuit for Module

This circuit diagram shows the connection among the components of the project i.e., GPS module, Ultrasonic Sensor and NodeMCU

V. RESULTS



Figure 6: Output on Google Maps on the Website

The degree of the junk can be detected by the ultrasonic sensor which thusly is associated with the NodeMCU. The NodeMCU is stimulated using the code written in Arduino IDE and the information is transmitted through MQTT protocol. The outcomes are seen on the website with area coordinates and the level of the garbage.

VI. CONCLUSION

Right now NodeMCU sensor-based mechanized trash checking system is created to screen the trash through the city. The system is increasingly compelling in advising the districts about the status regarding the trash at the trash container area when the status of the trash turns out to be completed.

Estimating the degree of the trash and illuminating the general public and districts about at which level the trash is and advising the driver to gather the trash is the fundamental element that is created in the venture which makes the framework progressively dependable and effective. The movement identification system is finished by the ultrasonic sensor to discover the nearness of an item towards the canister while the trash is full.

The interface and programming can be adjusted and redeveloped by the prerequisite of the framework for various city municipals with further research to help its proficiency and execution.

In spite of the fact that the advancement of the robotized trash observing framework is acceptable, there are things to be prescribed to chip away at it later on. Above all else, it is prescribed to add camera to the framework to catch the picture of the encompassing while the individuals attempt to drop the trash outside the canister which we will be utilized for punishment and

to include smell sensor and dampness sensor to detect nature and receptacle dampness so it will have more productivity and straightforward ease of use.

REFERENCES

- [1] M. N. Hassan, T. L. Chong, and M. M. Rahman, "Solid waste Management-What's the Malaysian position. Seminar waste to Energy," Universiti Putra Malaysia, 2005.
- [2] M. H. A. Wahab, M. R. Tomari, A. A. Kadir, and M. H. Jabbar, "Smart recycle bin a conceptual approach of smart waste management with integrated web based system," in Proc. International Conference on It Convergence and Security, Beijing, China, 2014.
- [3] L. Giusti, "A review of waste management practices and their impact on human health," United Kingdom, pp. 2228-2237, March 25, 2009.
- [4] C. Brown, M. Milke, and E. Seville, "Disaster waste management: A review article," Waste Management, vol. 31, no. 6, pp. 1085-1098, 2011.
- [5] Kanchan Mahajan, "Waste Bin Monitoring system using Integrated Technologies", International Journal of Innovative
- [6] Narayan Sharma,, "Smart Bin Implemented for Smart City",International Journal of Scientific & Engineering Research, Volume 6, Issue 9, September-2015

AUTHOR PROFILE:

Aayush is pursuing B.Tech in Electronics & Telecommunication Engineering at Bharati Vidyapeeth (Deemed to be) University. His area of interests lies in the domain of smart Communication Systems.

R. Satyateja is pursuing B.Tech in Electronics & Telecommunications Engineering at Bharati Vidyapeeth (Deemed to be) University. His area of interests lies in the domain of Smart Communication Systems.

Rohit Jaiswal is pursuing B.Tech in Electronics & Telecommunications Engineering at Bharati Vidyapeeth (Deemed to be) University. His area of interests lies in the domain of Smart Communication Systems.

Prof. Sonali P. Dash is working as a Assistant Professor in Bharati Vidyapeeth (Deemed to be) University College of Engineering, Pune, India. Her research interest includes Optical Communications and Photonics.