

ATMEGA 328P BASED SMART ENERGY METER TEST JIG USING PLX-DAX

Taufeeq Ahamed. M D¹, Muhamad Hareesh. M², Fahad. M T³, Karthick. C⁴

^{1,2,3}Student, Department of Electronics and Communication, Dhaanish Ahmed Institute of Technology, Tamil Nadu, India

⁴Professor, Department of Electronics and Communication, Dhaanish Ahmed Institute of Technology, Tamil Nadu, India

Abstract—The requirement for unit reading from energy meter to record the unit from the houses is still done by human assistants. The power accuracy is unknown for consumers and has to wait for bill to make payments. Due to manual reading human errors will occur and hence the value may not be accurate. An energy meter is developed which act as an interface between service provider and consumer. Large numbers of consumers who do not pay the bill at time make service provider loss ridden. Therefore, nonpaying bill by the consumers as a remote meter on/off based systems are implemented recently. Thus, reducing human labors and errors in meter reading and nuisance of non-payers of bill. The requirement of testing energy meter is very essential for calculating the efficiency of the system. In existing models multi meters are used for measuring the parameters by individually of the energy meter, which may cause delay for the assembling the board. In order to overcome this problem energy meter tester which can analyses more than one at the time is proposed.

Key words: Power accuracy, efficiency, parameters, multimeter.

1. INTRODUCTION

Smart Meters is a new product introduced by Government of India, and the technology is acquired from the technology partners. Smart meters being consumer products and are highly sensitive in the market need to be manufactured and calibrated to the required accuracy and tested for all the critical electrical parameters during the production stage itself. So, the testing of the smart energy meter is a must to check whether the meter is fit for connecting in the houses. There are various parameters for testing the energy meter before it is ready for packaging.

1.1. Existing System

The existing system of testing the smart energy meter is by using the multimeter. The multimeter is used for various testing mechanism. The smart energy meter is tested by

multimeter pins on the specific testing points designated for testing the voltage at the points.

1.2. Proposed System

The proposed model is eliminating the problems arise in the existing system. In this model, we used a board that is fitted with golden pins connected to the Arduino UNO. The Arduino relays the readings to a system or a laptop which is connected to the microcontroller. The data is acquired through a data collection software called PLX-DAX. The data collected is displayed in the excel sheet with the voltage readings of every testing points at regular intervals respectively.

2. LITERATURE SURVEY

2.1. Title:

Smart & Intelligent based AMR reader

- 1) Authors: Abhinandan Jain, Dilip Kumar, Jyoti Kedia
- 2) Methodology: This represents the development of fully Automated energy meter with capabilities like remote monitoring & controlling energy meter. The Automated Meter Reading (AMR), monitors the energy meter and sends data through SMS. This saves a lot of human costs.

2.2. Title:

Automated wireless meter reading system for Monitoring and Controlling power consumption

- 1) Authors: O. Homa Kesav, B. Abdul Rahim
- 2) Methodology: The energy meter reading system is fully automated and the power consumption is controlled. The ARM 7 based hardware system consist of a processor core board & the peripheral board. The embedded C language is used as programming language in this system.

3. Hardware Description

3.1. Arduino Microcontroller

Arduino is an open source physical processing hardware, which is based on a microcontroller board and an incorporated development environment for the board to be programmed.

The Arduino Uno is a microcontroller board based on the ATmega328 (datasheet). It has 14 digital input/output pins (of which 6 can be used as PWM outputs), 6 analog inputs, a 16 MHz crystal oscillator, a USB connection, a power jack, an ICSP header, and a reset button. It contains everything needed to support the microcontroller; simply connect it to a computer with a USB cable or power it with a AC-to-DC adapter or battery to get started. It is an 8-bit microcontroller based on RISC architecture.

The Uno differs from all preceding boards in that it does not use the FTDI USB-to-serial driver chip. Instead, it features the ATmega8U2 programmed as a USB-to-serial converter.

ATmega328

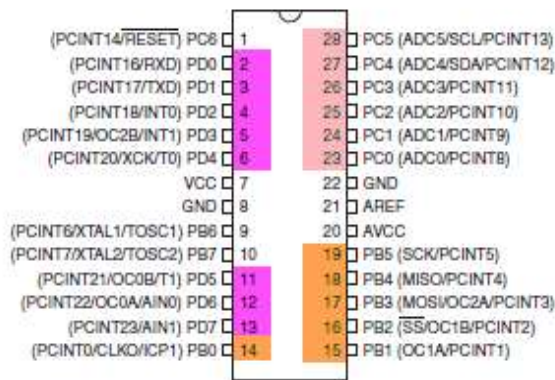

FIG: AT Mega 328p Pin Mapping

Reasons for Choosing Arduino Uno

- The reasons for choosing Arduino are listed as follows.
- Less expensive
- Compatible
- Expandable programming and opensource
- Allows easy and fast prototyping
- Easy to program

3.2. Power

The Arduino Uno can be powered via the USB connection or with an external power supply. The power source is selected automatically.

External (non-USB) power can come either from an AC-to-DC adapter (wall-wart) or battery. The adapter can be connected by plugging a 2.1mm center-positive plug into the board's power jack.

The board can operate on an external supply of 6 to 20 volts. If supplied with less than 7V, however, the 5V pin may supply less than five volts and the board may be unstable. If using more than 12V, the voltage regulator may overheat and damage the board. The recommended range is 7 to 12 volts.



FIG: Arduino Uno Micro Controller

3.3. Communication

The Arduino Uno has a number of facilities for communicating with a computer, another Arduino, or other microcontrollers. The ATmega328 provides UART TTL (5V) serial communication, which is available on digital pins 0 (RX) and 1 (TX). An ATmega8U2 on the board channels this serial communication over USB and appears as a virtual com port to software on the computer. The '8U2 firmware uses the standard USB COM drivers, and no external driver is needed. However, on Windows, a .inf file is required. The Arduino software includes a serial monitor which allows simple textual data to be sent to and from the Arduino board. The RX and TX LEDs on the board will flash when data is being transmitted via the USB-to-serial chip and USB connection to the computer (but not for serial communication on pins 0 and 1).

A Software Serial library allows for serial communication on any of the Uno's digital pins. The ATmega328 also supports I2C (TWI) and SPI communication. The Arduino software includes a Wire library to simplify use of the I2C bus; see the

documentation for details. For SPI communication, use the SPI library.

3.4. Power Supply

The ac voltage, typically 220V rms, is connected to a transformer, which steps that ac voltage down to the level of the desired dc output. A diode rectifier then provides a full-wave rectified voltage that is initially filtered by a simple capacitor filter to produce a dc voltage. This resulting dc voltage usually has some ripple or ac voltage variation.

A regulator circuit removes the ripples and also remains the same dc value even if the input dc voltage varies, or the load connected to the output dc voltage changes. This voltage regulation is usually obtained using one of the popular voltage regulator IC units.

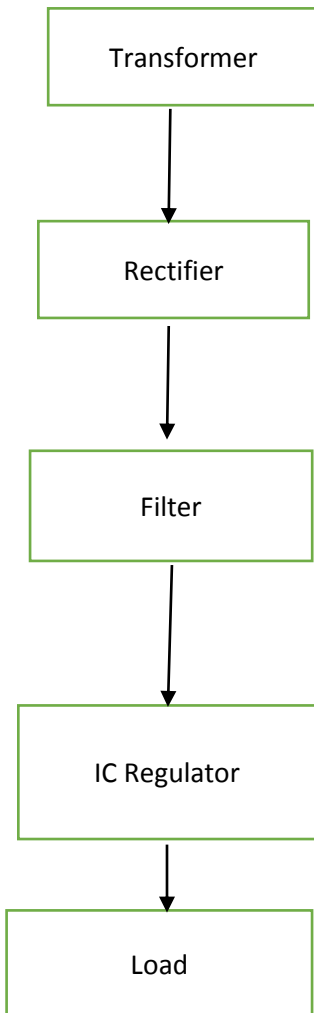

Fig: Block Diagram (Power Supply)

3.5. IC Voltage Regulators

Voltage regulators comprise a class of widely used ICs. Regulator IC units contain the circuitry for reference source, comparator amplifier, control device, and overload protection all in a single IC. IC units provide regulation of either a fixed positive voltage, a fixed negative voltage, or an adjustably set voltage. The regulators can be selected for operation with load currents from hundreds of milli amperes to tens of amperes, corresponding to power ratings from milli watts to tens of watts.

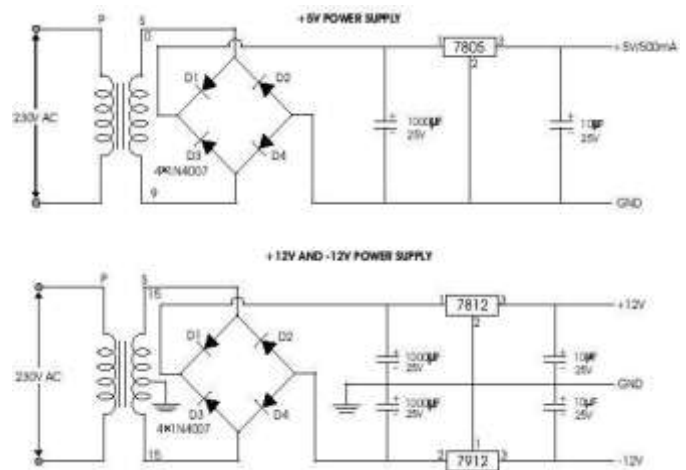

Fig: Circuit diagram (Power supply)

A fixed three-terminal voltage regulator has an unregulated dc input voltage, V_i , applied to one input terminal, a regulated dc output voltage, V_o , from a second terminal, with the third terminal connected to ground.

3.6. Channel Analog Multiplexer/Demultiplexer

UTC 4051 is single 8-channel analog multiplexers/demultiplexers for application as digitally-controlled analog switches.

The device has three binary control inputs and an inhibit input. It features low ON impedance and very low OFF leakage current. Control of analog signals up to the complete supply voltage range can be achieved.

3.7. The Main Board

The main board consists of 8 golden pins connected to the Arduino board from which it is in turn is connected to a system. This main board record the voltage measured by the energy meter and send to the system. The golden pins are used because the gold has high electrical conductivity. These pins act as the testing points and when the energy meter board is placed above the pins it shows the reading in the

system. The below is the systematic diagram of the main board.

4. BLOCK DIAGRAM

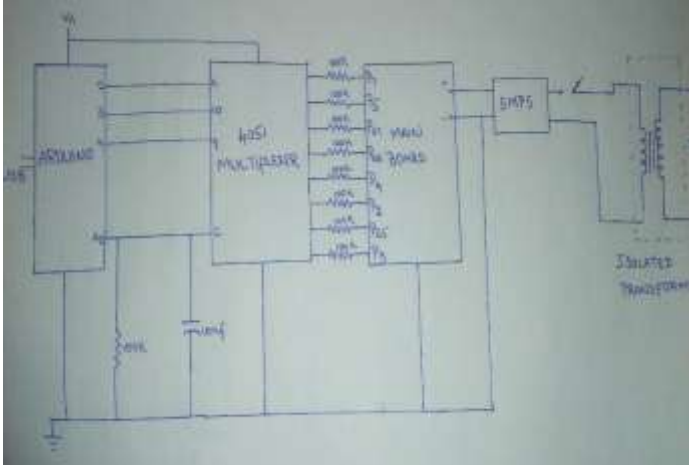

Fig: Block Diagram of Smart Energy Meter Test Jig

- The above figure is the block diagram of smart energy test jig.
- A Isolated Transformer is used in this project to stepdown the 230v power supply.
- Isolation Transformer is used for shock prevention.
- The transformer is connected to the Switched Mode Power Supply (SMPS), which acts as ON/OFF switch.
- The output of SMPS is 8.5v which is connected to the main board.
- As the main board has 8 testing pins, a multiplexer is used.
- Here IC 4051 is used for multiplexing. The IC consists of 16 Pins.
- There are 8 testing points on the Main Board. These Testing Points (TP) are connected to the Multiplexer through a 100k Resistor (Potential Divider).
- 8 Pins of IC are connected to the main board. 3 pins (A, B, C) are connected to the Digital pins of the Arduino (2,3,4)
- 2&3 are the address pins and 4 is the common.
- A common output C of the multiplexer is connected to the Analog pin A0 of the Arduino Board (AT Mega 328P).
- VCC is given to 16 and ground is connected to 8.
- Arduino send the data collected to the PC through multiplexer by Serial Communication.
- The data is acquired by data collection software called PLX-DAX.
- The data acquired is shown in the form of Excel sheet where all the voltages of the Testing Point are shown.

5. SOFTWARE DESCRIPTION

The software's used to accomplish this work are Arduino IDE and PLX-DAX.

5.1. Arduino IDE Software

The Arduino IDE is a cross platform developer tool written in Java. It allows you to control all of the software functions of your Arduino. Programs written using Arduino Software (IDE) are called sketches. The console displays text output by the Arduino Software (IDE), including complete error messages and other information. The bottom right hand corner of the window displays the configured board and serial port. The toolbar buttons allow you to verify and upload programs, create, open, and save sketches, and open the serial monitor.

Arduino is an open-source electronics platform based on easy-to-use hardware and software. You can tell your board what to do by sending a set of instructions to the microcontroller on the board. To do so you use the Arduino programming language (based on Wiring), and the Arduino Software (IDE), based on Processing.

Input & Output:

Each of the 14 digital pins on the Uno can be used as an input or output, using PinMode (), digitalWrite(), and digitalRead() functions. They operate at 5 volts. Each pin can provide or receive a maximum of 40 mA and has an internal pull-up resistor (disconnected by default) of 20-50 kOhms.

5.2. PLX-DAX

Parallax Data Acquisition tool (PLX-DAQ) software add-in for Microsoft Excel acquires up to 26 channels of data from any Parallax microcontrollers and drops the numbers into columns as they arrive. PLX-DAQ provides easy spreadsheet analysis of data collected in the field, laboratory analysis of sensors and real-time equipment monitoring. Any of our microcontrollers connected to any sensor and the serial port of a PC can now send data directly into Excel. PLX-DAQ has the following features:

- Plot or graph data as it arrives in real-time using Microsoft Excel.
- Record up to 26 columns of data. Mark data with real-time (hh:mm:ss) or seconds since reset.
- Read/Write any cell on a worksheet.
- Read/Set any of 4 checkboxes on control the interface.
- Baud rates up to 128K.
- Supports Com 1-15.

6. RESULTS

The output from the main board and the test pins was connected to the Arduino. From the Arduino the data collected is transferred to the pc by USB Cable. As there are 8 testing points(TP) on the PCB of Energy Meter, we will get 8 voltages from the 8 testing points. The 8 Testing Points are TP1, TP2, TP3, TP4, TP5, TP65, TP66, TP67.

The readings from the Testing Points are acquired by the data collection software called PLX-DAX. This software displays the voltages acquired in the form of Excel sheet. The serial number of the energy board which is to be tested is identified using a barcode. When the barcode is scanned, the serial number of the energy meter board automatically appears on the Excel Sheet.



Fig: Main Board with Testing Pins

The above Figure shows the testing pins with the numbers labelled along it.



Fig: Smart Energy Meter Test Jig with Meter board and Testing Pins.

The above Figure shows the test jig with the energy meter board placed above with the Testing pins.

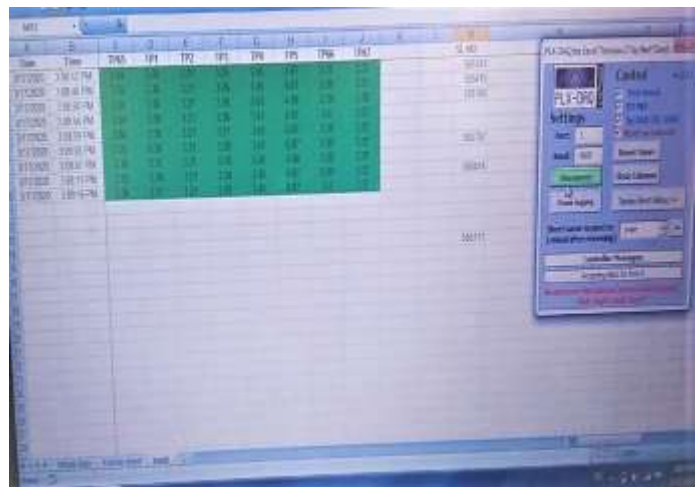

The voltages from the testing points are shown in the form of excel sheet. The serial number of the energy board is on the right side of the excel sheet. Extreme right is the PLX-DAX window where it is connected and disconnected. If all the

readings are in green color then the board has passed the test and is ready for packing. If any of the reading in red color then there is a mistake in the board and needs to be corrected. The above image shows the voltage readings of different energy boards with the PLX-DAX window.

7. CONCLUSION

In our project, we are able to test more than 500 board per shift. At a time, we can test 2 Energy Board which helps us in increasing the testing of boards with the increase in production. With this help, the cost occurred towards the human use can be decreased with only a few people required for this work. This helps in testing of Smart Energy Meters without errors as everything is automated and there is no human intervention except in changing the boards.

REFERENCES

- [1] Prof. M. S. Sujatha, Dr. M Vijay Kumar Dept. of EEE. "Online monitoring and analysis of faults in transmission and distribution lines using GSM technique", E-ISSN: 1817-3195. Vol. 33 No.2, 30th Nov, 2011.
- [2] Ms. Devjani Banerjee, Prof Dr. Mrs. N. R. Kulkarni Electrical Engineering Department. "Three Phase Parameter Data Logging and Fault Detection Using GSM Technology", ISSN 2250-3153, Volume 3, Issue 2, February 2013.
- [3] Andrea Zanella, Senior Member, IEEE, Nicola Bui, Angelo Castellani, Lorenzo Vangelista, Senior Member, IEEE, and Michele Zorzi, Fellow, IEEE, "Internet of Things for Smart Cities", IEEE Internet of Things Journal, vol. 1, no. 1, pp. 22-32, February 2014.
- [4] Poonam Borle, Ankitha Saswadhar, Deepali Hiwarkar, Rupali S Kali, "Automatic Meter Reading for Electricity", International Journal of Advanced Research in Electrical, Electronics and Instrumentation Engineering, Vol. 2, no. 3, pp. 982-987, March 2013.
- [5] S. Battermann and H. Garbe, "Influence of PLC transmission on the sensitivity of a short-wave receiving station," IEEE Power Line Communications and Its Applications, pp.224-227, Apr. 2005.
- [6] Sarwar Shahidi, Md. Abdul Gaffer, Khosru M. Salim, Design and implementation of Digital Energy Meter with data sending capability using GSM network.
- [7] A Review paper on Automatic Energy Meter Reading System, by Nitesh Rawat, Bhuvesh Yadav, Sona Rana, Neha Yadav from Dronacharya College of Engineering, Gurgaon, India.
- [8] V. Preethi, G. Harish, Design and Implementation of Smart Energy Meter.
- [9] Md. Sajedul Islam, Md. Sadequr Rahman Bhuiyan, Design and Implementation of Remotely Located Energy Meter Monitoring with Load Control and Mobile Billing System through GSM.
- [10] Dineshkumar.K, Prabhu Ramanathan, and Sudha Ramasamy, Development of ARM Processor based Electricity Theft Control System using GSM Network, in Proceedings of 2015 International Conference on Circuit, Power and Computing Technologies [ICCPCT].
- [11] International Conference on Electrical, Electronics, and Optimization Techniques (ICEEOT) 2016 Remote Location Tampering Detection of Domestic Load M.V. Bhatkar, India.
- [12] Archelle B. Batiller, Eula Frances I. Bugayong, Azzelle A. Caisip, Nylinel P. Coligado, Carmela Angeline C. Padilla, and Michael Angelo A. Pedrasa, Prepaid Metering System for Isolated Microgrids.
- [13] Masudur Rahman, Noor-E-Jannat, Mohd. Ohidul Islam and Md. Serazus Salakin, Arduino and GSM Based Smart Energy Meter for Advanced Metering and Billing System, in Proceedings of 2nd Int'l Conf. on Electrical Engineering and Information Communication Technology (ICEEICT) 2015 Jahangirnagar University, Dhaka-I 342, Bangladesh, 21-23 May 2015.
- [14] 2016 IEEE Students' Conference on Electrical, Electronics and Computer Science DESIGN OF EMBEDDED BASED AUTOMATED METER READING SYSTEM FOR REAL TIME PROCESSING Nayan Gupta, Medi-Caps Institute of Technology and Management, Indore (M.P.) Deepali Shukla Medi-Caps Institute of Technology and Management, Indore (M.P.)
- [15] Dipti Yeolekar, H.H. Kulkarni, and Dr. D.G. Bhardwaj, Real Time AMR Control of Household Energy Meter with Zigbee communication, in Proceedings of 2015