

Heartbeat Monitoring and Heart Attack Detection using IoT (Internet of Things)

Abhishek Kumar Anshu¹, Abhitosh Prakash Bando², Ms. Charu Shree³

¹Student of Computer Science and Engineering

²Student of Computer Science and Engineering

³Assistant Professor, Dept. of Computer Science and Engineering, Arya Institute of Engineering and Technology
Jaipur, Rajasthan, India

Abstract - In today's world, many people are losing their lives due to heart attacks and the shortage of specialist doctors available to take immediate action. Hence this system provides the implementation of heart rate monitoring and controlling of a patient. For this, we have used the technology called the "internet of things" to detect and monitor the heart rate of a patient. In this system, the patient will be equipped with the hardware consisting of sensors and other devices for measuring the heartbeat along with the notification unit to notify and provide data in real-time. The heartbeat sensor with advance measuring technique will calculate the heartbeat of the patient, and transmit it over the internet that can be easily accessed by the patient itself and the doctors through different electronic devices such as tablets, phones, and computers. The heartbeat limits are set on a system that informs about the high and low rate of heartbeat. It also provides continuous data for analyzing the chance of an attack on a patient.

Key Words: Heart beat, Heart rate, IOT(Internet of things), Heart Attack, Micro-controller

1. INTRODUCTION

The Heart is an important organ in the human body. It is used to pump blood and oxygen in the entire body through the circulatory system, keeping the functionality of the body organized[1]. As the pollution in the environment is increasing and also the food habits of the people becoming worse due to which rate of heart attack has been increased. It has been found that about 1 million people die due to heart diseases every year. A Heart attack generally occurs when a particular part of the heart dies resulting in the blockage of blood flow to the heart muscle. It has been observed that a heart attack takes 3 attempts to kill people and is considered to be a serious medical emergency and needs immediate medical action. Many people are losing their lives due to the heart attack which is the major issue to think over.

As in the advancement of technology, it is possible to reduce the death rates by controlling the heart attacks. The IoT (internet of things) which is the most emerging technology has brought a tremendous change in the field of health care[2]. The IoT provides the connectivity to several devices that can transmit data over the network without human interference. The "things" can be any physical objects present in the world along with the human being. In this technology, each device or object in the network is assigned a unique identifier to exchange real-time data and this data can be accessed with ease. IoT uses sensors and actuators for the communication between the physical objects or devices[5]. With the help of these devices pulse rate of a human can be gathered and observed frequently to prevent the heart attack. It is always not possible for the patient to be treated by a doctor when needed because of the busy schedule of the doctor. So this methodology of integrating sensors with IoT environment makes it possible to monitor and manage the patient remotely. The parameters like heart rate, heart rate variability, the temperature needs to be measured regularly to ensure the safety of the patient. Some of the control constraints are set in these devices which alerts the doctor as well as relatives of the patient whenever violated through the internet.

2. PROPOSED SYSTEM

The detection of a heart attack is done with the help of observing heart rate. The complete proposed work is based on the internet of things.

This method uses the following components as

- Pulse sensor
- Arduino
- Wi-Fi module

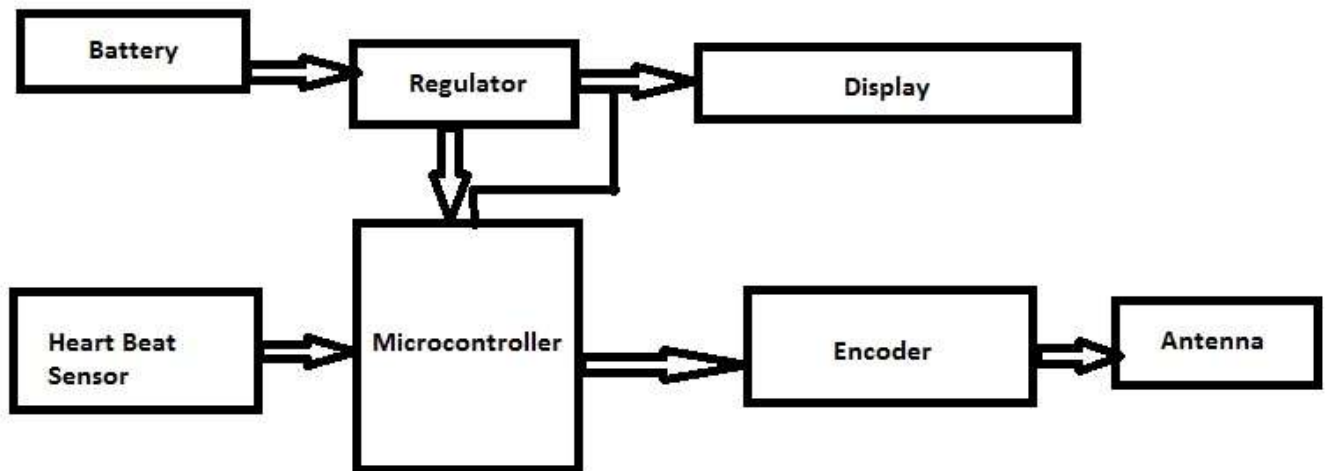

Fig-1: System architecture



Fig -2: Pulse sensor

Pulse Sensor is electronic device which is used to measure the heart-rate. It is provided with some circuitry that allows us to easily interface it with the arduino. It is being widely used by the students, athletes, artist and mobile developers to calculate the heart rate. The sensor is clipped onto a fingertip or earlobe and plugged into Arduino with some jumper cables to read data for further computation[3].

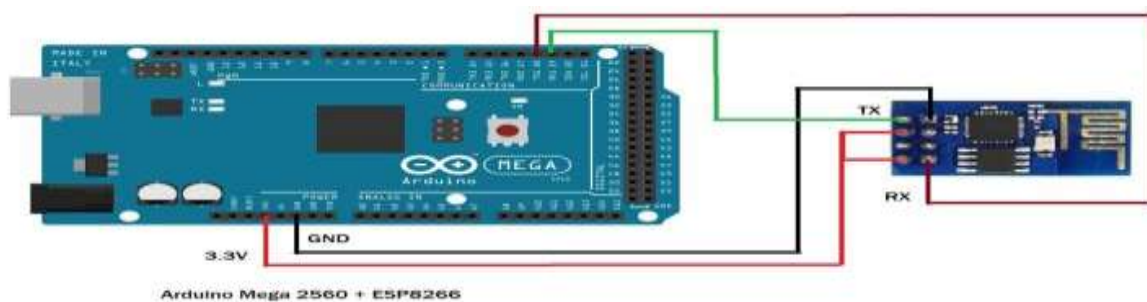

Fig-3: Arduino with Wi-Fi module

The Wi-Fi module is used to transmit data over the internet. The system uses a set of points that help us to determine whether the heartbeat of a person is normal or not which further helps in confirming the health of a person.

In case the heartbeat goes up or down the set point in the system will send an alert message. In this project, we are using an android application model to keep track of patient health.

3. WORKING METHODOLOGY

The two circuits have been taken into use:

- Transmitting circuit
- Receiver circuit

The transmitting circuit makes use of an automatic voltage regulator (AVR) micro-controller which is connected to the digitalize monitoring screen. For operating the circuit is provided with a 12v power supply using a transformer.

The buzzer and the LED light is used in the receiver circuit to provide the alert message in the case when the heartbeat rate crosses the threshold value. The light is measured through the ear by making the light to be blink through the transmission of the light through the light reliant resistor. LM358 op-AMP is used to collect the heart rate sensor reading which is used by the heartbeat unit based on the motion of blood to the fingertip. As the light intensity reaches 100%, it starts emitting when the structure equipped on IRTX towards the blood cells with 100% intensity. After this, the light reflects RX with 100% -x from it. Here the x is heartbeat rate. The data collected from this process is sent to the server so that in case of emergency immediate action can be taken. The digital form of output is connected to the micro-controller to compute then heartbeat in the form of a beat per minute (BPM)[4]. This data gathered is displayed on the LCD and the information is kept safe in the control room for future analysis.

4. ADVANTAGES

- The system is easy to move from one place to another.
- Reduces chaos due to a lack of doctors.
- Reduces the risk of death due to heart attacks.
- Available at affordable prices.
- It can also be used at home other than the hospital.
- It makes the medical field more sophisticated.

5. CONCLUSION

In today's time, the heart attack is one of the major problems faced by the people. Due to the low availability of doctors, heat patients can't get the proper treatment and care. Thus the technology like the internet of things has made it possible that people can keep their health records and also maintain it regularly by making use of the above-proposed system.

6. REFERENCES

- [1] Gowrishankar, S., M. Y. Prachita, and Arvind Prakash. "IoT based Heart Attack Detection, Heart Rate, and Temperature Monitor."
- [2] Mallick, Bandana, and Ajit Kumar Patro. "Heart rate monitoring system using fingertip through Arduino and processing software." *International Journal of Science, Engineering and Technology Research (IJSETR)* 5.1 (2016):84-89.
- [3] Patel, Shivam, and Yogesh Chauhan. "Heart attack detection and medical attention using motion-sensing device-Kinect." *International Journal of Scientific and Research Publications*4.1 (2014).
- [4] Aboobacker, Arith, Balamurugan, Deepak, Sathish "Heartbeat Sensing and Heart Attack Detection using Internet of Things: IoT" *International Journal of Engineering Science and Computing* April 2017.
- [5] Ajitha, U., et al. "IOT Based Heart Attack Detection and Alert System." *International Journal of Engineering and Management Research (IJEMR)* 7.2 (2017): 285-288.