

# Landmine Detection using Wireless Robot

Vachan B D<sup>1</sup>, B S Deepthi<sup>2</sup>, Geetha B C<sup>3</sup>, L Srinivasan<sup>4</sup>

<sup>1,2,3</sup>Information Science, New horizon College of Engineering, Bangalore, Karnataka, India.

<sup>4</sup> Professor, Dept. of Information Science and Engineering, New Horizon College of Engineering, Karnataka, India.

\*\*\*

**Abstract** – Land mine detection is most vital throughout war fare to deploy armed vehicle drive within the enemy territory. These armed vehicle or Main battle tanks are accustomed follow the trail of experimental tank operated by hand to avoid damage/disturbance of the battle tank and defense casualties of defense crews. additionally, post war fare the mines planted throughout war are often detected and subtle by deploying a mine detection mechanism, which may save civilian life to avoid human casualties. During this projected system, the most aim is to notice the Metal (Bomb) detection by mistreatment the wireless unmanned mechanism, that have the sensors that detects the presence of any silver object (bomb) through buzzer alarm. Because it could be a wireless mechanism it are often simply mobilized and might be controlled.

The mechanism consists of a metal detector at very cheap of it to sense the metal objects. It alerts the user employing a Buzzer on board. The RF detector works on 433MHz transmitter and receiver. During this system we tend to our employing a detector that detects the presence of any silver object (bomb) through buzzer alarm.

**Key Words:** Land mine detection, remote-controlled robot, buzzer, RF Sensor, Metal detector, Microcontroller.

## 1. INTRODUCTION

A land mine is an explosive gadget hidden under or on the ground and intended to obliterate the handicap foe targets, running from warriors to vehicles and tanks, as they disregard or close to it. Such a gadget is commonly exploded naturally by method for pressure when an objective strides on it or rolls over it, albeit other explosion components are utilized. This may cause harm by direct shoot impact, by parts that are tossed by the impact, or by both. The name starts from the old act of military mining, where passages were burrowed under foe strongholds or troop arrangements. These murdering burrows were first crumpled to decimate the objectives situated above, however they were later loaded up with explosives and exploded so as to cause much more noteworthy destruction. These days, in like manner speech, land mines for the most part allude to gadgets explicitly made as people killing or against vehicle weapons. In spite of the fact that numerous sorts of extemporized dangerous gadgets ("IEDs") can in fact be delegated land mines, the term land dig is normally saved for fabricated gadgets intended to be utilized by perceived military administrations, while IED is utilized for stopgap gadgets gathered by paramilitary.

## 1.1 HISTORY OF LANDMINES

The utilization of land mines is controversial in view of their potential as indiscriminate weapons. They can stay dangerous numerous years after a contention have finished, hurting the economy and human resources. With pressure from various crusade bunches organised through the International Campaign to Ban Landmines, a worldwide development to deny their utilization prompted the 1997 Convention on the Prohibition of the Use of the Stockpiling, Production and Transfer of Anti-Personnel Mines and on their Destruction, otherwise called the Ottawa Treaty. Until this point, 162 countries have marked the settlement. Land mines are commonly grouped into two sorts dependent on the kind of explosion that must be started, Anti-Tank mines they are intended to immobilize or pulverize vehicles and their inhabitants. In U. S. military phrasing obliterating the vehicles is alluded to as a cataclysmic slaughter while just incapacitating its development is alluded to as a portability execute. Hostile to tank mines are ordinarily bigger than people killing mines and require more strain to explode. The high trigger weight, typically requiring 100 kilograms (220 lb) keeps them from being set off by infantry or littler vehicles of lesser significance. Increasingly current enemy of tank mines utilize molded charges to center and increment the defensive layer entrance of the explosives. Anti-personnel mines Anti-work force mines are designed principally to slaughter or harm individuals, as opposed to the vehicles. They are often intended to harm instead of killing so as to expand the logistical help (clearing, clinical) burden on the opposing power. A few sorts of people killing mines can likewise harm the tracks or wheels of heavily clad vehicles. Under the Ottawa Treaty, the Parties embrace not to utilize, produce, reserve or move people killing mines and guarantee their demolition. Starting at mid 2016, 162 nations have joined the Treaty. Thirty-six nations, including the People's Republic of the China, the Russian Federation and the United States(US), which together may hold a huge number of stored people killing mines, are not yet gathering to the show.

## 1.2 AIM OF THE PROJECT

The main aim of this project is to detect the Metal (Bomb) discovery by utilizing the remote-controlled Robot, which have the sensors that distinguishes the nearness of any metallic item (bomb) through signal alert. As it is a remote Robot it tends to be effectively assembled and can be controlled.

## 2. IMPLEMENTATION

In this system we use micro controller, which is modified to control the information and yield modules interfaced to it. The controller utilizes a metal sensor to detect the land mines presence and give us a ready sign through ringer alert. We likewise utilize a remote, which is utilized to control the robot. The framework comprises of micro controller-based motherboard which is available with the Robot itself. It is interfaced with some DC engines for moving the robot and a RF for getting the guidelines from the remote.

This framework uses two DC Motors individually. The DC engine produces torque straightforwardly from DC power provided to the engine by utilizing interior compensation, stationary perpetual magnets, and turning electrical magnets. It takes a shot at the rule of Lorentz power, which expresses that any current conveying conductor set inside an outside attractive field encounters a torque or power known as Lorentz power. Points of interest of a brushed DC engine incorporate low beginning cost, high dependability, and straightforward control of engine speed. Hindrances are high support and miscreant length for high power employments. Maintenance includes consistently supplanting the brushes and springs which convey the electric flow, just as cleaning or supplanting the commutator. These parts are essential for moving electrical force from outside the engine to the turning wire windings of the rotor inside the engine.

The driver is used for or by the DC Motors is L293D. The Device is a monolithic integrated high voltage, high current four channel driver is designed to acknowledge standard DTL or TTL rationale levels and drive inductive loads of the system, (for example, transfers solenoids, DC and venturing engines) and exchanging power transistors. This venture utilizes a microcontroller, which is modified, with the assistance of installed C guidelines. This Microcontroller is fit for communicating with input and output modules. The controller is interfaced with dc engines, which are fixed to the Robot to control the course of the Robot.

### The fundamental targets of this system are:

1. Design of real-time robot.
2. Wireless control of robot directions and movements.
3. Real time metal detection.
4. Audible alerts using bell alert.

### 2.1. MAIN COMPONENTS DISCRPTION

#### 2.1.1. METAL SENSOR

This DC 5-36V M12 Inductive 4mm PNP-NO Proximity Sensor Switch is a part broadly utilized in programmed control industry for detecting, controlling, and non-contact exchanging. When the proximity switch is near some objective article, it will convey control signal.

At the point when the metal methodologies close closeness switch detecting territory, an Eddy Current is prompted in metal. Which thus upsets the attractive field created by the Inductive Proximity Sensor. The change seen here is detected by the sensor.

This inductive vicinity switches can be non-contact, no pressure, no flash, immediately gave the electrical order. Precisely reflect the position and the stroke movement mechanism. Positioning exactness, working recurrence, administration life. Simple to install and appropriate for harsh situations.

This 4mm closeness sensor can distinguish an assortment of metals, smaller than usual size, long life, low cost, protected sort establishment, hostile to obstruction capacity, 1mm identification separation, utilizing for exact situating of molds, accuracy machine devices, and robots.

#### Features:

1. Red LED checks the state of the proximity sensor
2. High repeated positioning accuracy
3. High switching frequency
4. Wide voltage range
5. Outer (Theard) Diameter: M12
6. Antivibration, dust, water and oil prevention
7. Reverse power protection, short circuit protection, directly connecting with PLC.
8. Can replace small switches and limit switches.

#### 2.1.2. RF TRANSMITTER:

The ST-TX01-ASK is an ASK Hybrid transmitter module. ST-TX01-ASK is planned by the Saw Resonator, with an effective low cost, small size, and it is also simple-to-use for designing.

Frequency Range: 315 / 433.92 MHZ.

Supply Voltage: 3~12V.

Output Power: 4~16dBm [as prescribed in reference 2 ]

Figure 1: 315/434 MHZ RF TRANSMITTER



**Features of RF transmitter:**

1. 433.92 MHz Frequency
2. Less expensive
3. 1.5-12V operation
4. 11mA current consumption at 3V
5. Smaller in size
6. 4 dBm output power at 3V

**Specifications of RF transmitter:**

Operation Voltage Vcc: 1.5 to 12 Volts DC  
 Operation Current: Icc - 11mA @3V, 59mA @5V  
 Frequency Accuracy: -75 to 75 KHz  
 Center Frequency: 433 Mhz  
 RF Output Power: 4 dBm@3V (2 mW), 16 dBm@5V (39 mW)  
 Data Rate: 200 to 3K bps  
 Temperature: -20 to +60 Deg. C  
 Power up delay: 20 ms [as prescribed in reference 2]

**Applications**

1. Remote Keyless Entry (RKE)
2. Remote Lighting Controls
3. On-Site Paging
4. Asset Tracking
5. Wireless Alarm and Security Systems
6. Long Range RFID
7. Automated Resource Management
8. Wireless security systems
9. Car Alarm systems
10. Remote controls.

11. Sensor reporting
12. Automation systems

**2.1.3. RF RECEIVER:**

The ST-RX02-ASK is an ASK Hybrid receiver module. The effective low-cost solution for this is using at 315/433.92 MHZ. The circuit shape of ST-RX02-ASK is L/C.

Receiver Frequency: 315 / 433.92 MHZ

Typical sensitivity: -105dBm

Supply Current: 3.5mA

IF Frequency: 1MHz

**Features:**

1. Less power consumption.
2. Easy for all application.
3. Operating temperature range: - 20°C~ +70°C
4. Operating voltage: 5 Volts.
5. Frequency Range: 315/434 MHz

Figure 2: 315/434 MHz RF RECEIVER



**Features**

1. Less expensive.
2. 5V operation
3. 3.5mA current drain
4. No External Parts are required
5. Receiver Frequency: 433.92 MHZ
6. Typical sensitivity: -105dBm
7. IF Frequency: 1MHz

**Applications**

1. Car security system
2. Sensor reporting
3. Automation system
4. Remote Keyless Entry (RKE)

5. Remote Lighting Controls
6. On-Site Paging
7. Asset Tracking
8. Wireless Alarm and Security Systems
9. Long Range RFID
10. Automated Resource Management

PIC 16C5X 12-bit program word  
 PIC16CXXX and PIC16FXXX 14-bit program word  
 PIC17CXXX and PIC18CXXX 16-bit program word

The features, pin description of the microcontroller used are conversed in the following sections.

**Description:**

**Introduction to PIC Microcontrollers:**

PIC stands for Peripheral Interface Controller introduced by the Microchip Technology to recognize the single chip microcontrollers. These devices have been more successful in 8-bit microcontrollers. The main aspect is that Microchip Technology has continuously upgraded the existing device design and architecture and added required peripherals to the microcontroller to suit the customers' needs. The development tools such as the assembler and simulator are freely available on the internet at [www.microchip.com](http://www.microchip.com)

**Low - end PIC Architectures**

Microchip PIC microcontrollers are available in various number of types. When PIC microcontroller MCU was first available from the General Instruments in early 1980's, the microcontroller consisted of a simple processor executing 12-bit wide instructions with basic Input and output functions. These devices are also known as low-end architectures. They have limited program memory and are meant for applications which need simple interface functions and small program & data memories. Some of these low-end device numbers are

- 12C5XX
- 16C5X
- 16C505

**Mid range PIC Architectures:**

Mid range PIC architectures are build by upgrading the low end architectures and including more number of peripherals, more number of different registers and more data or program memory. Some of the mid range devices are as follows:

- 16C6X,
- 16C7X.
- 16F87X

Program memory type is indicated by a particular alphabet as shown below

C=>EPROM, F=> Flash, RC=> Mask ROM

**2.1.4. MICRO CONTROLLER:**

Figure 3: Microcontrollers



**Introduction to Microcontrollers:**

Conditions that we find ourselves in nowadays in the arena of microcontrollers had their early development in the development of technology of cohesive circuits. This development has made it conceivable to store hundreds of thousands of transistors into one chip. That was a precondition for invention of microprocessors, and the first computers were made by totaling external peripherals such as memory, input-output lines, timers and other. Supplementary cumulative of the volume of the package resulted in conception of combined circuits. These integrated circuits contained both processor and peripherals. That is how the initial chip encompassing a microcomputer, or what would advance be known as a microcontroller came about.

Microprocessors and microcontrollers are extensively used in embedded systems products. Microcontroller is a programmable device. A microcontroller has a CPU in accumulation to a fixed amount of RAM, ROM, I/O ports and a timer embedded all on a single chip. The static amount of on-chip ROM, RAM and number of I/O ports in microcontrollers makes them superlative for many applications in which cost and space are grave.

The microcontroller used in this project is PIC16F877A. The PIC families of microcontrollers are developed by Microchip Technology Inc. Presently they are some of the most widespread microcontrollers, selling over 120 million devices each year. There are fundamentally four families of PIC microcontrollers:

PIC12CXXX 12/14-bit program word

Popularity of the PIC microcontrollers is due to the following few factors.

1. Speed: Harvard Architecture, RISC architecture, one instruction cycle = 4 clock cycles.
2. Instruction set simplicities: These instruction sets consists of only 35 instructions as opposed to 111 instructions for a 8051.
3. Power on reset and brown out reset. Brown out reset means that when the power supply goes below a
4. specified voltage (say 4V), it causes PIC to reset; hence malfunction is avoided. A watch dog timer (user programmable) resets the processor if the software or the program ever malfunctions and diverge from its normal operation.
5. PIC microcontroller has four optional clock sources.
  - Low power crystal
  - Mid range crystal
  - High range crystal
  - RC oscillator (low cost).
6. Programmable timers and on-chip ADC.
7. Up to 12 independent interrupt sources.
8. Powerful output pin control (25 mA (max.) current sourcing capability per pin.)
9. EPROM/OTP/ROM/Flash memory option.
9. I/O port expansion capability.

[as prescribed in reference 2]

**CPU Architecture:**

The CPU makes use of Harvard architecture with separate Program and Variable (data) memory interface. This facilitates instruction fetch and the operation on data or on accessing of the variables can be done simultaneously. Architecture of PIC micro controller.

Figure 4: Architecture of PIC microcontroller

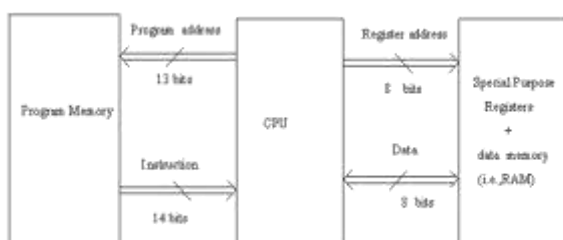

Basically, all PIC microcontrollers has the following features:

- RISC instruction set with around 35 instructions\_9
- Digital I/O ports.
- On-chip timer with 8-bit prescaler.
- Power-on reset
- Watchdog timer
- Power saving SLEEP mode
- Direct, indirect, and relative addressing modes
- External clock interface
- RAM data memory
- EPROM (or OTP) program memory

**Peripheral features:**

- High sink/source current 25mA
- Timer0: 8-bit timer/counter with 8-bit prescaler can be incremented during sleep via external crystal/clock
- Timer2: 8-bit timer/counter with 8-bit period register prescaler and post scalar.
- Capture, Compare, PWM (CCP) module
- Capture is 16-bit, max resolution is 12.5ns
- Compare is 16-bit, max resolution is 200 ns
- PWM max, resolution is 10-bit
- 8-bit 5 channel analog-to-digital converter
- Synchronous serial port (SSP) with SPI (Master/Slave) and (Slave)

[as prescribed in reference 4]

**Some devices offer the following additional features:**

- Analogue input channels
- Analogue comparators
- Additional timer circuits
- EEPROM data memory
- Flash EEPROM program memory
- External and timer interrupts
- In-circuit programming
- Internal oscillator
- USART serial interface



Figure 5: PIN DIAGRAM OF PIC16F877

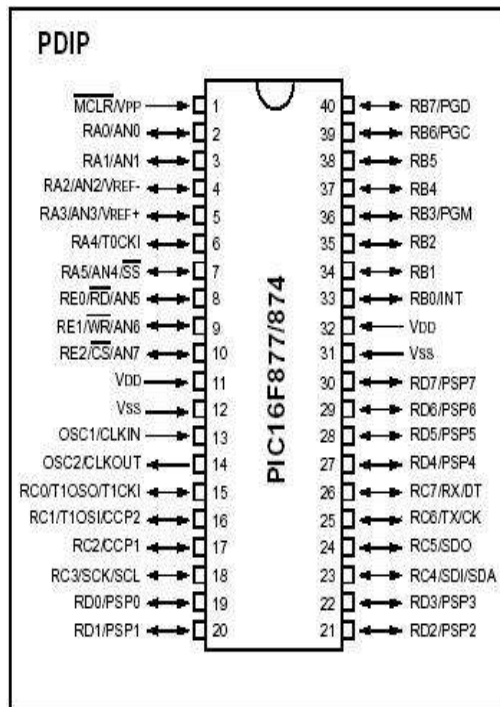

Pic16f877 is a 40 pin microcontroller. It has 5 ports port A, port B, port C, port D, port E. All the pins of the ports are for interfacing input output devices.

Port A: It consists of 6 pins from A0 to A5

Port B: It consists of 8 pins from B0 to B7

Port C: It consists of 8 pins from C0 to C7

Port D: It consists of 8 pins from D0 to D7

Port E: It consists of 3 pins from E0 to E2

The rest of the pins are obligatory pins these should not be used to attach input/output devices.

Pin 1 is MCLR (master clear pin) pin also denoted as reset pin.

Pin 13, 14 are used for crystal oscillator to attach to generate a frequency of about 20MHz.

Pin 11, 12 and 31, 32 are used for voltage source Vdd(+) and Vss(-)

**PIC 16F877A Specification:**[as referred from reference 4]

RAM	36bytes
EEPROM	256bytes
FlashProgramMemory	8kwords
Operating Frequency	DC-to-20MHz
I/O port Port A,B,C,D,E	

This is the specification for PIC16F877A from Microchip. A single microcontroller which is very laid-back to be

assembled, program and also the price is very low-priced. It cost less than 10 dollar. The virtuous thing is that single unit can be purchased at that 10 dollar price. Contrasting some other Integrated Circuit that must be bought at a minutest order extent such as 1000 units or 2000 units or else you won't be able to purchase it.

One unit of PIC16F877A microcontroller can be programmed and obliterated so many epochs. Some said about 10 000 times. If you are undertaking programming and copying your code into the PIC 20 times a day that means you can do that for 500 days which is more than a year!

The expunging time is almost unnoticeable because once new program are encumbered into the PIC, the old program will inevitably be erased immediately.

**RAM:**

PIC16F877A previously made with 368 bytes of Random-Access Memory (RAM) inside it. Any momentary variable storage that we wrote in our program will be stored inside the RAM. Using this microcontroller, you don't need to buy any exterior RAM.

**EEPROM:**

256 bytes of EEPROM are accessible also inside this microcontroller. This is very useful to store statistics such as PIN Number, Serial Number and so on. Using EEPROM is very substantial because data deposited inside EEPROM will be reserved when power supply is turn off. RAM did not stockpile data everlastingly. Data inside RAM is not reserved when power supply is turn off.

The dimensions of program code that can be deposited is about 8k words inside PIC16F877A ROM. 1 word size is 14 bits. By using the legalized version of the CCS C compiler only 2k words of program can be inscribed and compiled. To transcribe 8k words of C program you have to obtaining the original CCS C compiler and it cost less than 700 dollar.

**Crystal oscillator:**

The crystal oscillator speed that can be associated to the PIC microcontroller range from DC to 20Mhz. Consuming the CCS C compiler normally 20Mhz oscillator will be used and the price is very cheap. The 20 MHz crystal oscillator should be related with about 22pF capacitor.

There are 5 input/output ports on PIC microcontroller specifically port A, port B, port C, port D and port E. Each port has dissimilar function. Most of them can be used as I/O port.

**3. LITERATURE SURVEY**

The basic concept behind the land mine has shown up through military history. Many of the sources reported that Zhuge Liang, the Kingdom of Shu of China, invented a land mine sort of device in the third century. Forces in ancient Rome sometimes had dug small foot-sized holes, covered them and armed with a sharpened spike. In the Middle Ages in Europe, small, four-pronged spiked devices called caltrops or crows' feet could be spread on the ground to delay the approach of an enemy. Around

14th century or 15th century, the Ming Dynasty started to make some of the primal modern mines with powder, which is in the form of stone, ceramic or pig iron.

The first modern mechanically fused high explosive anti-personnel land mines were designed by Confederate troops of Brigadier General Gabriel J. the Raines during the Battle of Yorktown in 1862. (As a Captain, Raines were earlier employed explosive booby traps during the Seminole Wars in Florida in 1840. Both mechanically and electrically fuzed "land torpedoes" were employed, although by the end of the war mechanical fuzes were found to be generally more reliable. Several of these designs were unpremeditated on the fields; especially from volatile shells by the end of the war everywhere 20000 standard patterns "Raines mines" had been deployed.

Improved designs of mines were designed in the Imperial Germany, circa 1912, and were copied and manufactured by almost all major participants in the First World War. In World War One, land mines were used noticeably at the beginning of the battle of Passchendaele. Before the war was over, the British started manufacturing land mines that contained contaminated poison gas instead of explosives. Poisonous gas mines were manufactured until the 1980s in the Soviet Union. The United States was known to have the least experimented with the concept in the 1950s (Dany, 1998).

#### 4. PROPOSED SYSTEM

In this section, schematic diagram and interfacing of PIC16F877 microcontroller with each module is taken into consideration.

Figure 6: schematic diagram of Wireless RF based Bomb detection Robot

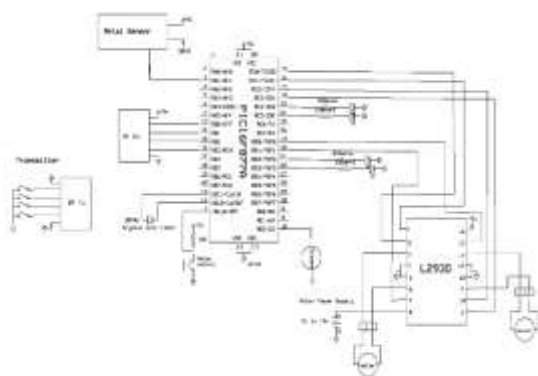

The above schematic diagram of **Wireless RF based Bomb detection Robot** explains the interfacing section of each component with micro controller and ultrasonic sensor module. The crystal oscillator associated to 13<sup>th</sup> and 14<sup>th</sup> pins of micro controller and regulated power supply is also connected to micro controller and LED's also connected to micro controller through resistors and motor driver connected to the micro controller.

#### 5. CONCLUSIONS

Considering the highlights of all the hardware components utilized have been created in it. Nearness of each module has been contemplated out and set carefully, hence contributing to the finest working of the unit. Secondly, utilizing profoundly progressed IC's with the assistance of developing innovation, the venture has been effectively actualized. In this way, the project has been effectively planned and tried.

In future we can utilize this system in a few applications by including extra components to this. By interfacing remote camera to the robot, then we can see the external world from our individual computer only by utilizing GPRS and GPS. We are able to utilize this robot at numerous areas and we are able utilize to handle numerous other circumstances.

#### REFERENCES

- [1] Jaradat M A, Bani Salim M N and Awad F H (2012), "Autonomous Navigation Robot for Landmine Detection Applications", 8th International Symposium on Mechatronics and its Applications (ISMA), April, pp. 1-5.
- [2] Kuo-Lan Su, Hsu-Shan Su, Sheng-Wen Shiao and JrHung Guo (2011), "Motion Planning for a LandmineDetection Robot", Artificial Life and Robotics
- [3] Ray, A.K. "GPS and sonar based area mapping and navigation by mobile robots", 7th IEEE International Conference on Industrial Informatics, 2009, pp.801-806, 23-26 June 2009.
- [4] L. Robledo, M. Carrasco and D. Mery, "A survey of land mine detection technology" International Journal of Remote Sensing Vol. 30, No. 9, 10 May 2009, 2399-2410 [2] Rasaq Bello, "Literature Review on Landmines and Detection Methods" Frontiers in Science.
- [5] Waqar Farooq, Nehal Butt, Sameed Shukat, Nouman Ali Baig, Sheikh Muhammad Ahmed, "Wirelessly Controlled Mine Detection Robot" 2016 International Conference on Intelligent Systems Engineering (ICISE)
- [6] Jebasingh Kirubakaran.S.J, Anish kumar jha, Dheeraj kumar, Sadambi Poornachandran Prakash, "Mine Detecting Robot with Multi Sensors Controlled Using HC-12 Module" International Journal of Engineering & Technology .
- [7] V. Abilash and J. Paul Chandra Kumar, "Arduino Controlled Landmine Detection Robot" 2017 Third International Conference On Science Technology Engineering and Management (ICONSTEM)
- [8] Bharath J, "Automatic Land Mine Detection Robot Using Microcontroller", International Journal of Advance Engineering and Research Development Volume 4, Issue 3, March-2017

[9] Seong Pal Kang, Junho Choi, Seung-Beum Suh, Sungchul Kang, "Design of mine detection robot for Korean mine field."

[10] Michael YU. Rachkov, Lino Marques, Anibal T. De Almeida, "Multi-Sensing Demining Robot."