

“IOT Based Automatic Vehicle Accident Detection and Rescue System”

Harshita Singh¹, Kajal Tiwari², Prashant Pandey³, Rashmi Maheshwari⁴

^{1,2,3}Dept. of Electronics Engineering, Shree L.R. Tiwari College of Engineering, Maharashtra, India

⁴Professor, Dept. of Electronics Engineering, Shree L.R. Tiwari College of Engineering, Maharashtra, India

Abstract –Internets of Things-enabled Intelligent Transportation Systems (ITS) are gaining significant attention in academic literature and industry, and are seen as an answer to enhancing road safety in smart cities. Due to the ever increasing number of vehicles, a big rise within the number of road accidents has been observed. Vehicles embedded with a plethora of sensors enable us to not only monitor the present situation of the vehicle and its surroundings but also facilitates the detection of incidents. Significant research, for instance, has been conducted on accident rescue, particularly on the utilization of data and Communication Technologies (ICT) for efficient and prompt rescue operations.

The majority of such works provide sophisticated solutions that specialise in reducing response times. However, such solutions are often expensive and aren't available altogether sorts of vehicles. Given this, we present a completely unique Internet of Things-based accident detection and reporting system for a sensible city environment. The proposed approach aims to require advantage of advanced specifications of smartphones to style and develop a low-cost solution for enhanced transportation systems that's deployable in legacy vehicles. In this context, a customized Android application is developed to collect information regarding speed, gravity, pressure, sound, and site.

The speed is a factor that is used to help improve the identification of accidents. It arises due to clear differences in environmental conditions (e.g., noise, deceleration rate) that arise in low speed collisions, versus higher speed collisions).The information acquired is further processed to detect road incidents. Furthermore, a navigation system is additionally developed to report the incident to the closest hospital. The proposed approach is validated through simulations and comparison with a true data set of road accidents acquired from Road Safety Open Repository, and shows promising leads to terms of accuracy.

1. INTRODUCTION

It is recognized that cities are becoming increasingly crowded in terms of visitors, inhabitants and vehicles. The increase in the number of vehicles has led to an increase in traffic, which has led to an increase in the number of road traffic accidents. A recent World Health Organization (WHO) report showed that every year 1.35 million people die and 50 million people get injured. Road accidents are ranked as the eighth leading cause of deaths (up from ninth in its previous report in 2015), with the Association for

Safe International Road Travel (ASIRT) predicting that it may rise to the fifth leading cause of deaths in the near future, unless drastic changes occur. As well as the social harm caused by road traffic accidents, there is a significant cost. ASIRT estimates that between one and two percent of the annual budget of every country is spent on road accidents. Recently, there has been a global increase in the annual number road traffic deaths, even in developed countries with good road safety measures. However, it remains the case that the greatest burden of road traffic fatalities and injuries lies in low- and middle-income countries. The emergence of the Internet of Things (IoT) gives promise for the development of intelligent traffic management systems. Global Navigation Satellite Systems, such as the Global Positioning System (GPS), are being increasingly used in many applications, especially for vehicle positioning and navigation. Indeed, many vehicles that are shipped today have GPS devices that sense the position of the vehicle and send this information to cloud servers. Other sensors, for use in accident detection or smart transport management, are also present in modern vehicles and continually acquire and store data. High sampling rates, driven by a desire for increased accuracy and algorithm efficacy, lead to significant challenges in the storage and analysis of this data. There are many different definitions of IoT. For example, in its Special Report on the IoT, the Institute of Electrical and Electronics Engineers (IEEE) describes the IoT as ‘a network of items—each embedded with sensors—which are connected to the Internet’.

All definitions realise the IoT as a cyber-physical system that connects physical objects to cyberspace. The extent and application of the IoT is significant and includes a variety of objects such as vehicles, buildings, mobiles, and different electronics appliances and infrastructural devices or even clothes.

Commonly, in an IoT system, a network connects devices—each with a unique identifier. These physical objects may have Radio-Frequency Identification (RFID) tags or other forms of identification, such as bar codes, and their presence is detected by a variety of sensors. These sensors take the object-specific information as an input and send it over the network to a system for processing and analysis. This processed data is then sent to decision-making units to determine automated actions to be invoked. However, it should be recognized that sensors have limited computational power and storage capacity and this can create challenges, especially regarding security and

trustworthiness.

1.1 APPLICATIONS

1. Security and remote monitoring of vehicles especially during military operations.
2. School transport vehicle accident detection.
3. This project can be used for cab or car of companies.

1.2 OBJECTIVE

The proposed design of the system can detect accidents in significantly lesser time duration and sends the relative information like accurate time and exact location of vehicle accident to the rescue team, which will help in saving precious lives.

1.3 PROBLEM STATEMENT

The development within the field of automobiles is very increasing and which results in the accidents then many hazards thanks to traffic. People's life are under high risk. This situation prevails, just because there is a lack of emergency facilities in our country.

In our country, many people lose their life because of accidents. Because of casualties or improper communication to rescue team. The rapid rise of technology and infrastructure has made our lives easier. The high demand of automobiles has also increased the traffic hazards and road accidents.

We are in the process of solving this issue by proposing an efficient solution and to reduce the loss of lives as much as possible.

2. BLOCK DIAGRAM

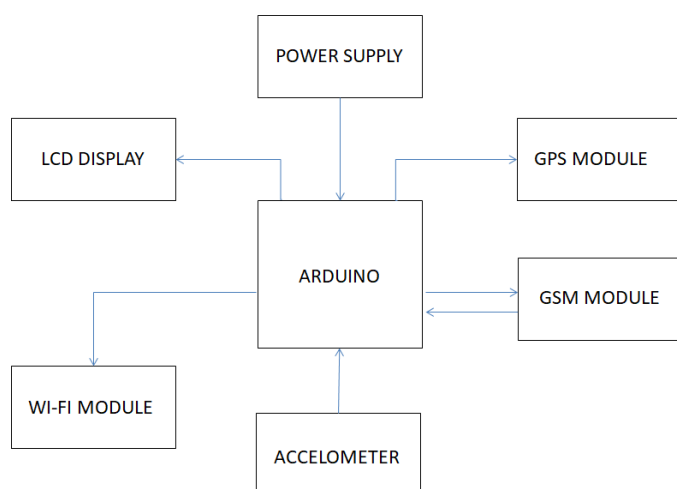

3. CIRCUIT DIAGRAM

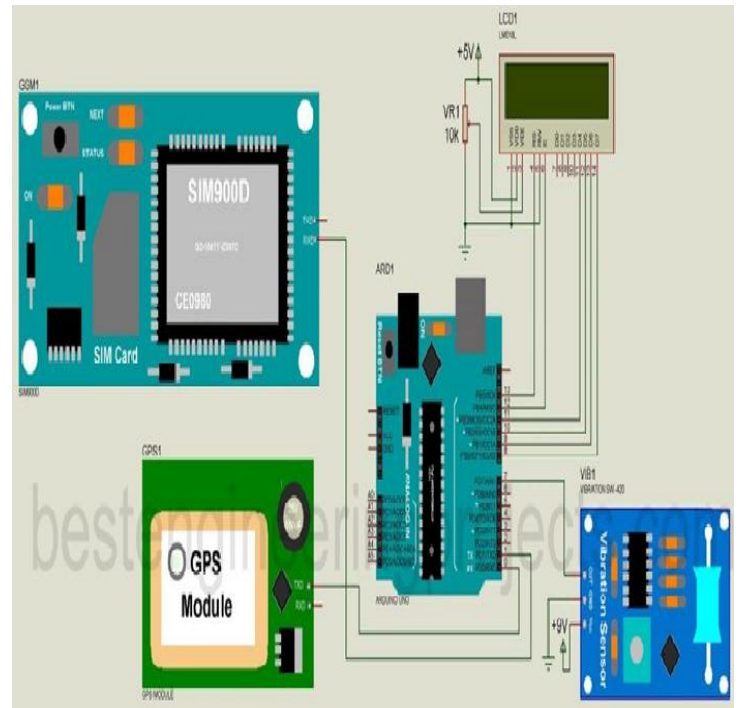

3.1 MOTOR driver L293D

L293D are a dual H-bridge motor driver microcircuit (IC). Motor drivers act as current amplifiers since they take a low-current control signal and supply a higher-current signal. This higher current signal is employed to drive the motors. L293D contains two inbuilt H-bridge driver circuits. In its common mode of operation, two DC motors are often driven simultaneously, both in forward and reverse direction.

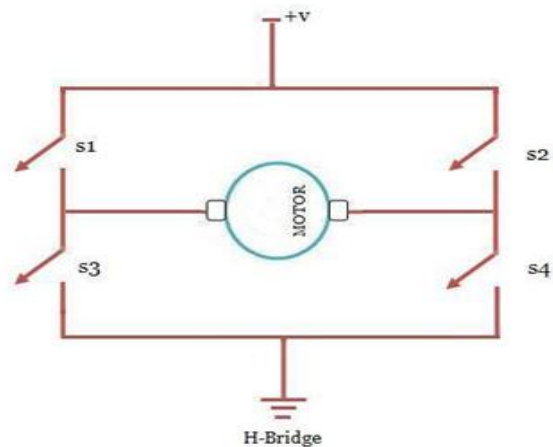

3.2 DC- MOTOR

A DC motor is an electric motor that runs on direct current (DC) electricity. In any electric motor, operation is based on simple electromagnetism.

A simple 2-pole DC electric motor (here red represents a magnet or winding with a "North" polarization, while green

represents a magnet or winding with a "South" polarization).

Every DC motor has six basic parts -- axle, rotor (a.k.a., armature), stator, commutator, field magnet(s), and brushes.

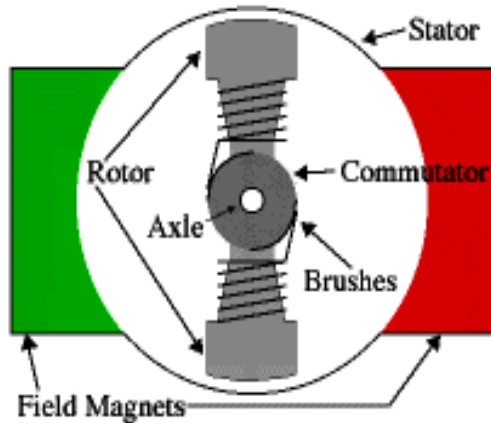

3.3 Arduino

The Arduino microcontroller is a simple to use yet powerful single board computer that has gained considerable traction within the hobby and professional market. The Arduino is open-source, which suggests hardware is fairly priced and development software is free. The Microcontroller used here is an Arduino UNO. The UNO may be a Microcontroller board supported ATMEGA 328P. The ATMEGA 328P has 32kB of non-volatile storage for storing code. The board has 14 digital input and output pins, 6 analog inputs, 16 MHz quartz crystal, USB, an ICSP circuit and a reset button. The UNO are often programmed with the Arduino software.

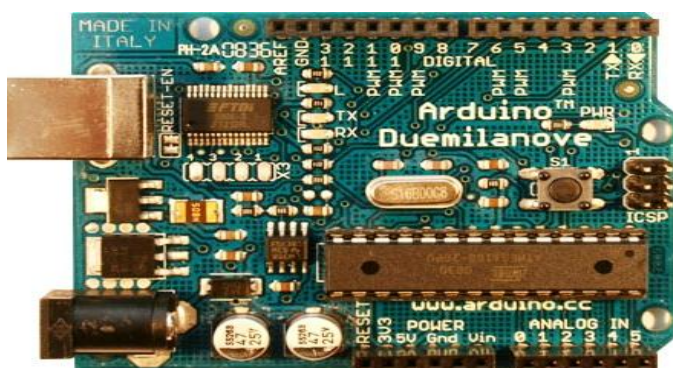

3.4 GSM MODEM

A GSM modem are specialized sort of modem which accepts a SIM card, and operates over a subscription to a mobile operator, a bit like a mobile .From the mobile operator perspective, a GSM modem looks a bit like a mobile .When a GSM modem is connected to a computer, this enables the pc to use the GSM modem to communicate over the mobile network. While these GSM modems are

most often wont to provide mobile internet connectivity, many of them also can be used for sending and receiving SMS and MMS messages.



3.5 GPS MODULE

GPS Module continuously receives the info from the satellite and transmits correspondingly to the UART of microcontroller.

The GPS signal is applied to the antenna input of module, and an entire serial data message with position, velocity and time information is presented at the serial interface. The Valid data Received are going to be within the format of RMC....latitude and longitude positions.

3.6 WIFI MODULE

The unit that makes this project Internet of Things compatible is ESP8266 Wi-Fi module. This module is a self-contained OC having an integrated TCP/IP protocol stack which gives any microcontroller- based board an access to the internet. It come with a pre- programmed AT command set firmware.

The maximum operating voltage of ESP8266 is 3.6V But to make the Arduino Uno and ESP8266 communicate, a Logic Level Converter is needed since ESP8266 is not capable of 3-5V logic shifting. The Rx and Tx pins of ESP8266 are connected to the logic level converter which is connected to the Arduino Uno. With the help of this module, we can set up the Arduino board to the cloud platform and the transfer of data can be done wirelessly.



3.7 ACCELEROMETER SENSOR

ADXL335 complete, low-power 3-axis accelerometer measures dynamic acceleration (motion, shock, or vibration) and static acceleration (tilt or gravity) over a $\pm 3g$ range with 0.3% nonlinearity and 0.01%/ $^{\circ}C$ temperature stability.

The user selects the bandwidth of the accelerometer using the CX, CY, and CZ capacitors at the XOUT, YOUT, and ZOUT pins. Measurement bandwidth can be selected to suit the application from 0.5 Hz to 1600 Hz for X- and Y- axes and from 0.5 Hz to 550 Hz for the Z-axis.

Operating on a single 1.8 V to 3.6 V supply, the ADXL335 consumes 350 μA . Available in a 16-lead LFCSP package, it is specified from $-40^{\circ}C$ to $+85^{\circ}C$.

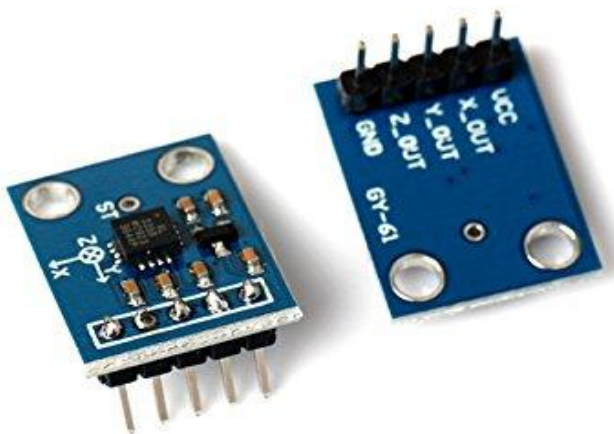

3.8 16X2 LCD Display

Most common LCDs connected to the microcontrollers are 16x2 and 20x2 displays. This means 16 characters per line by 2 lines and 20 characters per line by 2 lines, respectively. The standard is mentioned as HD44780U, which refers to the controller chip which receives data

from an external source (and communicates directly with the LCD).

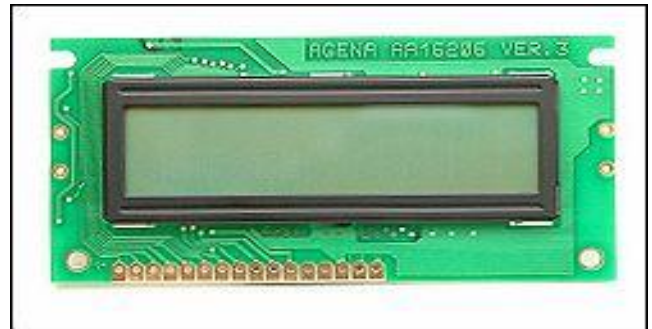

3.9 POWER SUPPLY

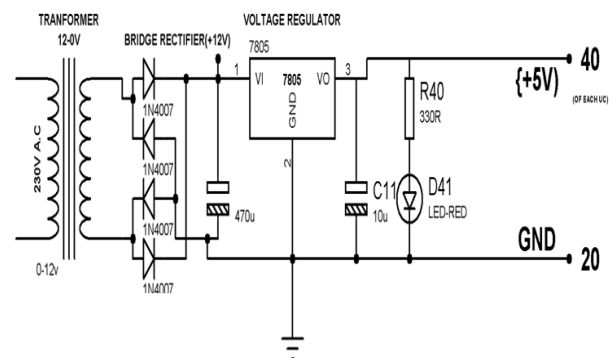

The circuit uses standard power supply comprising of a step down transformer from 230v to 12v and 4 diodes forming a Bridge Rectifier that delivers pulsating dc which is then filtered by an electrolytic of about 470microf to 100microF. The filtered dc being unregulated IC LM7805 is employed to urge 5v constant at its pin no 3 regardless of input dc varying from 9v to 14v. The regulated 5volts dc is further filtered by a little electrolytic of 10 micro f for any noise so generated by the circuit. One LED is connected of this 5v point serial with a resistor of 330ohms to the bottom i.e. negative voltage to indicate 5v power supply availability.

4. SOFTWARE REQUIREMENTS:-

4.1 INTRODUCTION TO ARDUINO (IDE)

The Arduino integrated development environment (IDE) is a cross-platform application (for Windows, macOS, Linux) that's written within the programming language Java. It is wont to write and upload programs to Arduino compatible boards, but also, with the assistance of 3rd party cores, other vendor development boards.

The ASCII text file for the IDE is released under the GNU General Public License, version 2. The Arduino IDE supports the languages C and C++ using special rules of code structuring. The Arduino IDE supplies a software library from the Wiring project, which provides many common input and output procedures.

User-written code only requires two basic functions, for starting the sketch and therefore the main program loop, that are compiled and linked with a program stub main() into an executable cyclic supervisory program with the GNU toolchain, also included with the IDE distribution. The Arduino IDE employs the program avrdude to convert the executable code into a document in hexadecimal encoding that's loaded into the Arduino board by a loader program in the board's firmware.

4.2 INSTALLING THE ARDUINO* IDE

This guide contains steps to install the Arduino* IDE on a system with Windows*, OS X®, or Linux*. These steps were tested using the 1.6.8 version of the Arduino IDE. Requirements

You have connected your board to your computer and gathered any required components. See the list of requirements for details. Choose your operating system Windows.

4.3 THINGSPEAK

According to its developers, "Thing Speak is an open source Internet of Things (IOT) application and API to store and retrieve data from things using the HTTP protocol over the Internet or via a Local Area Network. Thing Speak enables the creation of sensor logging applications, location tracking applications, and a social network of things with status updates" Thing Speak was originally launched by Iobridge in 2010 as a service in support of IOT applications. Thing Speak has integrated support from the numerical computing software MATLAB from Math Works, allowing Thing Speak users to analyze and visualize uploaded data using MATLAB without requiring the acquisition of a MATLAB license from Math works

5. Working of the Accident Detection and Alert System using Arduino:-

1. When accident is occurred, the location details of vehicle/object collected by the GPS module from the satellite, this information is in the form of latitude and longitude scale.
2. Thus, collected information is then fed to arduino uno. Necessary processing is completed and therefore the information is passed to the LCD and GSM modem.
3. The GSM modem collects the information for arduino uno and then transfer it to the mobile phone through the SMS which is in text format.

6. CONCLUSIONS

A privacy-preserving public auditing system for data storage security in cloud computing. We utilize the homomorphism linear authenticator and random masking to guarantee that the TPA would not learn any knowledge about the data content stored on the cloud server during the efficient auditing process, which not only eliminates the burden of cloud user from the tedious and possibly expensive auditing task, but also alleviates the users' fear of their outsourced data leakage.

Considering TPA may concurrently handle multiple audit sessions from different users for their outsourced data files, we further extend our privacy-preserving public auditing protocol into a multiuser setting, where the TPA can perform multiple auditing tasks in a batch manner for better efficiency.

REFERENCES

- [1] Zhao Y. Mobile phone location determination and its impact on intelligent transportation systems. IEEE Trans. Intell. Transp. Syst. 2000.
- [2] Ali H.M., Alwan Z.S. Car Accident Detection and Notification System Using Smartphone. Int. J. Comput. Sci. Mob. Comput. 2015.
- [3] Aloul F., Zualkernan I., Abu-Salma R., Al-Ali H., Al-Merri M. iBump: Smartphone application to detect car accidents. Electrical Eng. 2014.