

# Seismic Analysis of Circular Shape RC Building by Using Shear Wall at Different Position

Disha Dhingra<sup>1</sup>, Sonu Mangla<sup>2</sup>

<sup>1</sup>M.Tech, Structural Engineering, College- VCTM, Aligarh, Uttar Pradesh, India

<sup>2</sup>Assistant Professor, College- VCTM, Aligarh, Uttar Pradesh, India

\*\*\*

**Abstract** - Purpose of this paper to know the seismic variation in the circular shape building by providing the shear wall at a different position in the reinforced concrete building. In this paper, there are three models in which at first model shear wall provided at the outer wall of the building, in the second model shear wall provided at the mid of the building and in the third model shear wall provided at the inner wall of the building. The method used for the analyzing of these all models is dynamic analysis (time history analysis) and software used for the analysis of all model is Etabs. The code used for this dynamic analysis is IS(Indian Standard ) 1893 part-1: 2016 and all models exist in the seismic zone fourth. After analyzing all model we will compare the seismic parameter (lateral storey force, storey displacement, periods and frequency, stiffness of the storey ) value concerning all model and check that which model is stable as compare to other two models.

**Key Words:** Dynamic analysis, time history, RC building, Shear Wall, Circular building, Etabs

## 1. INTRODUCTION

Nowadays every RCC building design for the earthquake-resistant because the height of the building increasing day by day which increases the overturning moment due to this building get fail in the overturning if the height of the building of the low then the value of the overturning moment and base shear low because the value of the base shear and overturning moment depend upon the self-weight of the structure.

The main motive of using circular shape building to decrease the effect dynamic (wind and Seismic) on the structure, and we provided the shear wall at a different position in this circular shape structure. We know that material used in the circular shape building is 15 to 18% less than as compared to the rectangular shape building. There is little difficulty in the circular shape building is to make a joint between the circular column and a rectangular beam. All models of this paper come under the Courtyards circular building because Courtyards circular building provided the free space inside it.

## 2. METHODOLOGY

For the analysis of these three models, we used some method such as Dynamic Analysis, Etabs Software and Indian Standard code 1893 part-1:2016. Dynamic Analysis is

a method of the analysis of the structure when the variation of the load concerning the time is more, according to the IS code 1893 part-1: 2016, clause 7.7.3 dynamic analysis is classified into the two type:

- i. Time History Method
- ii. Response Spectrum Method

### 2.1 Time History Method

According to the clause 7.7.4 from IS code 1893 part-1: 2016, time history method shall be based on appropriate ground motion and shall be performed using the accepted principle of earthquake structural dynamics. The data of the time history is taken from "ELCENTRO". The time history method come under the dynamic analysis where the variation of the lateral force concerning time is maximum, if the variation of the lateral force concerning the time is low then we should use static analysis method.

Etabs software is developed by the CSI company and it used for both analysis and designing of the structure.

## 3. MODELLING

In this paper, there are three models in the first model (Model-01) shear wall provided at the outer side of the building, in the model second (Model-02) shear wall provided at mid-wall of the building, in the third model (Model-03) shear wall provided at the inner wall of the building.

All parameter (material, building configuration, seismic) of this circular shape building is given below in details:

### 3.1 Material Parameter

In this parameter, we give the details about the material which is used in this RCC circular building and material parameter is given below in the table:

**Table -1:** Material Parameter.

S. No	Material	Grade
1.0	Concrete	M30 & M25
2.0	Longitudinal Bar	Fe415
3.0	Stirrup Bar	Fe250

### 3.2 Building Parameter

In this parameter, we provide the information about structure parameter such as size of beam, column, shear wall and slab is given below in table:

**Table -2:** Building Parameter

S.No	Building Parameter	Value
01.	Beam	250 mmX400 mm
02.	Column	400 mm diameter
03.	Slab	160 mm
04.	Span of Beam	4.0 m
05.	Height of building	33.0m
06.	Floor height	3.0m
07.	Ground storey	3.0m
08.	Shear Wall	230.0 mm
09.	External Diameter	72.0m
10.	Internal Diameter	32.0m
11.	Area	4380 m <sup>2</sup>

### 3.3 Seismic Parameter

In this factor, we were given the factor of the seismic where the model is assumed to construct such as seismic zone factor, Importance factor, etc

**Table -3:** Seismic Parameter

S.No	Seismic Parameter	Value
01.	Seismic Zone Factor (Z)	0.24 (Forth Zone)
02.	Response Reduction Factor (R)	5
03.	Importance factor (I)	1.2
04.	Soil type	2nd
05.	Eccentric ratio	5%

### 3.4 Load Parameter

The load which is acting on the model such as Imposed load is given in the table:

**Table -4:** Load Parameter

S.No	Load Parameter	Value
01.	Live load	3.0KN/m <sup>2</sup>
02.	Partition wall	7.0KN/m
03.	Load distribution wall	14.0KN/m

### 3.5 Shear Wall at Outer wall on Structure (Model-01)

The plan, elevation and three-dimensional view of the model-01 (where shear wall provided at the outer wall of the building) are given below:

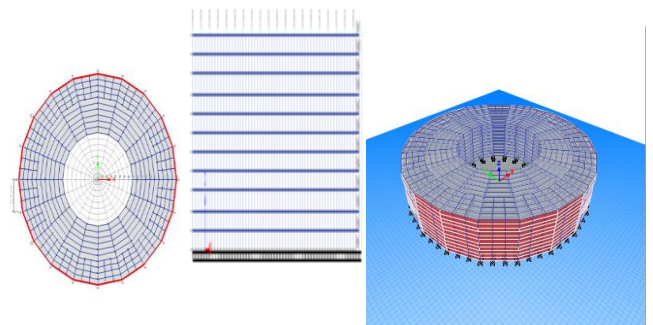

**Fig -1:** Plan, Elevation and 3D View of Model-01

### 3.6 Shear Wall at Mid wall on Structure (Model-02)

The plan, elevation and three-dimensional view of the model-02 (where shear wall provided at mid-wall of the building) are given below, the elevation of the model-02 is same as model-01.

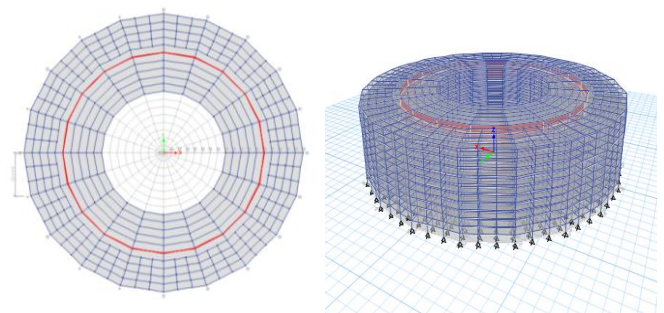

**Fig -2:** Plan and 3D View of Model-02

### 3.7 Shear Wall at Inner wall on Structure (Model-03)

The plan, elevation and three-dimensional view of the model-03 (where shear wall provided at the inner wall of the building) are given below, the elevation of the model-03 is same as model-01.

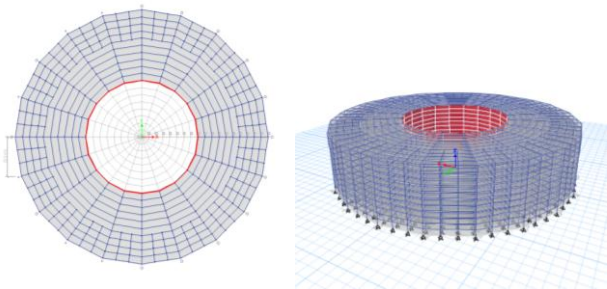

Fig -3: Plan and 3D View of Model-03

## 4. CALCULATION AND ANALYSIS

After analyzing all these three model, there are following result come out and we have taken some parameter to compare the value of these three models, such parameter is the natural period, base shear, storey stiffness, storey drift, maximum storey displacement.

### 4.1 Natural Period

From clause 3.18 the natural period in the mode of oscillation is defined as the time (in second) taken by structure to complete one cycle of the oscillation in its natural mode of oscillation. The following graph represents the variation of the natural period:

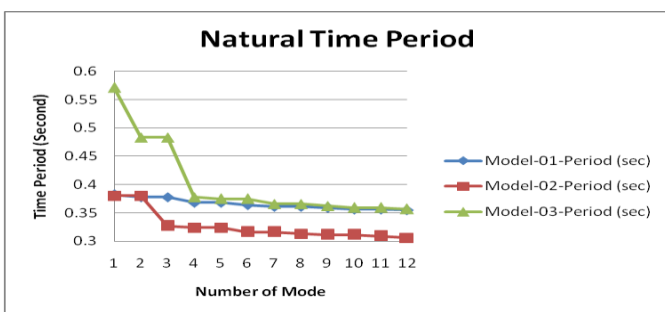

Chart -1: Natural period

From the Indian Institute of Technology Kanpur, earthquake tips number 10 give the reference that “storey one to storey 20 storey buildings are usually in the range 0.05-2.00 sec.” from this our model is in a safe condition.

### 4.2 Base Shear

From the clause 7.2.1 in Indian Standard code 1893 part-1: 2016, the base shear is defined as the lateral forces which act at every floor due to seismic effect on the structure. The

following graph represents the base shear of all models in the X direction due to applying the seismic effect in X direction:

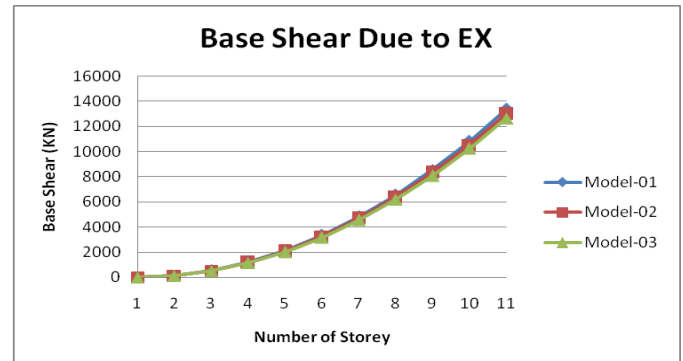

Chart -2: Base Shear due to EX

From the above graph, we can see that the value of the base shear is maximum in the model-01. And the minimum value of the base shear in the model-03 (where the shear wall provided at the inner wall of the circular RC building).

### 4.3 Maximum Storey Displacement

Maximum storey displacement is defined as the maximum displacement of the floor from the ground surface due to lateral force which acts at the structure. The value of the maximum storey displacement does not measure concerning floor level. The graph of displacement of all models is given below:

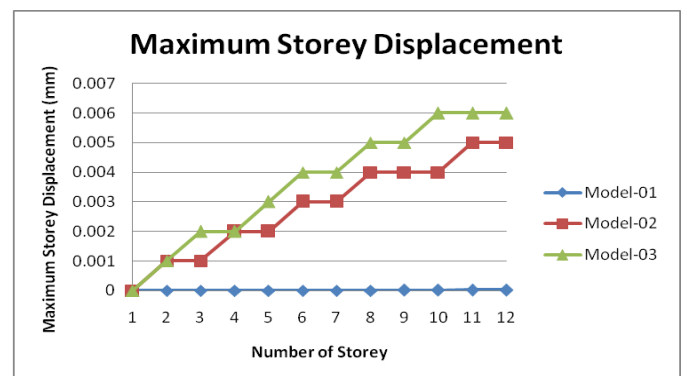

Chart -3: Maximum Storey Displacement

From the above graph, the value of the storey displacement in the model-01 is very less as compared to the two models.

### 4.4 Storey Stiffness

Storey stiffness is defined as the ratio of the storey shear to the storey drift of the structure. The graph of the storey stiffness of all models is given below:



Chart -4: Storey Stiffness

From the above graph, we can see that the value of the storey stiffness is maximum in the Model-01 (shear wall provided at the outer wall of the RC circular building).

## 5. CONCLUSIONS

From the above dynamic analysis of all models, we have taken some seismic parameter to choose the stable model, and we found a few conclusions after analyzing all models, which are given below:

- I. When we provide the shear wall at the mid-wall or centre wall of the Circular RC building then the value of the natural period is low as compared to model when the shear wall is provided at the outer wall or inner in the circular building, and from the result, we can choose the Circular RC building by providing the shear wall at the centre wall in the building on the case to reduce the natural period.
- II. The value of the lateral force due to applying seismic in the X direction is low in the model-03 (where the shear wall provided at the inner wall of the circular RC building) because the dead load of the Model-03 is less as compared to the other two models.
- III. The value of the maximum storey displacement in the model-01 (where the shear wall provided at the outer wall of the circular RC building) because the lateral force due to seismic is directly acting at the outer wall of the circular building and we provided shear wall at the outer wall of the circular RC building because the main purpose of the shear wall to reduce the effect of the lateral forces on the RC structure.
- IV. In the model-03 (where the shear wall provided at the inner wall of the circular RC building) the value storey stiffness is minimum as compared to the other two models, it's because of the value of the storey drift maximum and value of the base shear is low in the model-03.
- V. From the above conclusion, we found that when the shear wall provided at the mid or centre of the building is more stable because shear wall resists

the outer forces and inner forces, but in the model-02 the storey displacement is high as compared to the model-01.

## REFERENCES

- [1] G. Mathiyazhagan "Finite Element Analysis on Curved Beams of Various Sections" 2013.
- [2] Shaikh A. Aijaj, G.S. Deshmukh "Seismic Analysis of Vertically Irregular Building" 2013, (<https://sites.google.com/site/researchjournalofsrtmun/>).
- [3] Philip Steadman "Architectural Doughnuts: Circular-Plan Buildings, with and without Courtyards" Nexus Netw J (2015) 17:759–783, DOI 10.1007/s00004-015-0270-8.
- [4] Mohaiminul Haque, Sourav Ray "Seismic Performance Analysis of RCC Multi-Storied Buildings with Plan Irregularity" 2016; 4(2): 52-57, DOI: 10.11648/j.ajce.20160403.11.
- [5] Anju Nayas "seismic analysis of irregular RC frame buildings with special columns" Volume 4, Issue 6, June - 2017, International Journal of Advance Engineering and Research Development.
- [6] Sanisha Santhosh "Seismic Analysis of Multi Storied Building with Shear Walls of Different Shapes" Vol. 6 Issue 06, June - 2017, International Journal of Engineering Research & Technology (IJERT).
- [7] Yaseen Tarique, Vijayalaxmi Gajare "Seismic Behavior of Circular Building with Mass Irregularity" Volume: 05 Issue: 05 | May-2018, IRJET.
- [8] IS 456-2000 "Code practice for plain and reinforced concrete".
- [9] [24] IS:875(Part 2)-1987 "Code of Practice for design loads for buildings and structures"
- [10] IS 1893-2016, Criteria for earthquake resistant design of structures, Bureau of Indian Standard, New Delhi.