

# 5G Architecture using GAN based Digital Transmitter in VLSI Design for Low Pass Filter

R Keerthana B.E ECE, Mrs.P.SRIDEVI,M.E. ASSOCIATE PROFESSOR,  
Mr.B.GOWRI SANKARAN, M.TECH., (P.h.D)

\*\*\*

**Abstract** - In fifth generation, digital amplification is obtained by cryptography the baseband signal into a binary bit stream and amplifying this signal with an easy switch. The needed analog signal is fixed up in an exceedingly straightforward passive low-pass filter. To elucidate the principle of operation, needs, and new opportunities enabled by the utilization of digital transmitter chains. Advances in digital technology enabled large reductions in physical size and power consumption whereas still increasing the quality of the modulation schemes used. The transition from the digital into the analog domain sometimes takes place before the up-converter stage. Moving the mixer and electronic equipment into the digital domain opens broad potentialities in terms of size reduction, configurability, frequency gracefulness and power savings. This project allows US to attain to maneuver the boundary between the digital and also the analog world even nearer to the antenna with the provision of contemporary high-speed GaN processes by exchange the band pass filter by low pass filters.

most encodable amplitude is considerably lower compared to PWM. This puts high demands on the shift speed and potency of the PA. Recent approaches so use digitally implementable mixtures of PWM and delta-sigma modulation, as an example envelope delta-sigma modulation (EDSM). Another issue to be thought of is that the correction of inevitable electronic equipment distortions. whereas ancient digital predistortion (DPD) techniques can work, they need a further, power-hungry building block. For transmitters within the watt output power vary this is able to scale back the potency noticeable. A higher approach may be a predistortion theme that's specifically tailored to the distortions of digital power amplifiers.

**Key Words:** GaN, EDCM, BPDSM, PWM, HEMT

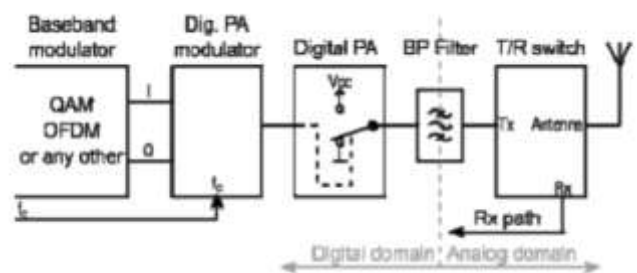

Fig 1: Full digital transmitter chain

## 1. INTRODUCTION

Over the previous few decades transmitters affected from analog baseband (BB) generation to totally digital baseband processors. Advances in digital technology enabled large reductions in physical size and power consumption whereas still increasing the quality of the modulation schemes used. The transition from the digital into the analog domain sometimes takes place before the upconverter stage. the supply of contemporary high-speed GaN processes currently allows US to maneuver the boundary between the digital and therefore the analog world even nearer to the antenna. Moving the mixer and electronic equipment into the digital domain parades broad potentialities in terms of size reduction, reconfigurability, frequency gracefulness, and additionally power savings.

## 2. STYLE APPROACH

Today, the overwhelming majority of digital PAs uses a two-level (binary) theme as delineate .To convert the many-level baseband signal into a binary stream, analog pulse-width modulation has been utilized in the past . whereas it will give a awfully clean output spectrum, the analog nature of this modulator makes it onerous to implement and needs tough standardization of individual units. Band-pass delta alphabetic character modulation (BPDSM) , on the opposite hand, will be enforced with customary digital logic however utilizes additional signal edges per CF cycle and also the

## 2.1. THE SWITCH POWER AMPLIFIER

In principle, the digital electronic equipment solely consists of associate electrically governable switch. Since the merchandise of current flow and fall over a perfect switch is usually zero, in distinction to any analog electronic equipment, efficiencies of 100% area unit on paper potential. The difficult task is to create a switch that may handle the required output power at change speeds within the vary of the CF whereas still maintaining moderately steep edges so as to stay change losses low. Thanks to the high harmonic content of binary waveforms in no time change transistors have to be compelled to be used. Presently the sole on the market material that may give output powers within the watt vary for this mode of operation at microwave frequencies is GaN.

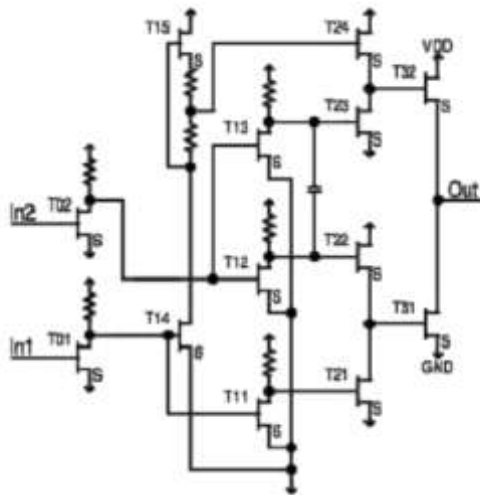

Fig 2: Schematic of switch PA MMIC

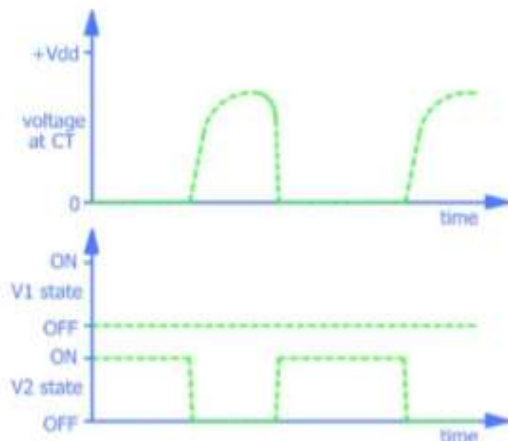

Fig. 3. Voltage characteristic at final-stage of proposed digital PA vs. time for high power back-off level.

### 2.2 OUTPUT FILTER

The output filter restores the needed analog transmit signal from the amplified binary signal. The conversion from digital to analog is completed by low-pass filtering the wished carrier and reflective all out of band tones into the electronic equipment. The precise location of the unwanted tones powerfully depends on the digital PA modulator used, however modulator ideas exist that place unwanted tones so much out of band. This allows the utilization of straightforward filters with terribly low insertion loss and compact dimensions.

### 2.3 TRANSMIT / RECEIVE SWITCH

To complete the absolutely capable transmitter chain, a T/R switch. To stay the potency up, the switch needs to give a awfully low insertion loss whereas still having the ability to handle the total peak power of the electronic equipment. Again, GaN with its high breakdown voltage and high frequency capability is a perfect match.

### 2.4 MODULATOR

In order to learn from the advances within the field of digital logic circuits, the modulator ought to be enforced mistreatment normal digital building blocks. Also, the modulator ought to be tailored to the AMPLIFIER properties like minimum change times and will give an influence economical thanks to correct for electronic equipment distortions while not employing a full DPD. This was the motivation to develop a modulator that's supported already existing (reconfigurable) digital technologies. The design of the modulator delineate relies around a serializer and a digital electric circuit because it is usually on the market in FPGAs and ASICs. Waveforms that may be generated by the serializer area unit keep in an exceedingly wave-table. They are doing not have to be compelled to be restricted to pulse WIDTH modulation, however can even involve additional advanced multiple- pulse waveforms. To accommodate a particular electronic equipment behaviour, waveforms that cause dangerous potency of the electronic equipment or different unwanted behaviour area unit far from the list. A delta-sigma modulator selects between these entries in an exceedingly means that the wished amplitude is earned and unwanted tones area unit shifted so much out of band presents the spectrum at the modulator's output for 5MHz and 20MHz wide signals with six.5dB PAPR at a carrier of 900MHz. ACLR values in way over 60dB (5MHz signal) resp. 50dB (20MHz signal) area unit reached. any details will be found in potency was measured to be forty second with a 5MHz six.5dB PAPR signal at 900MHz. this idea is the image of however uses the improved AMPLIFIER.

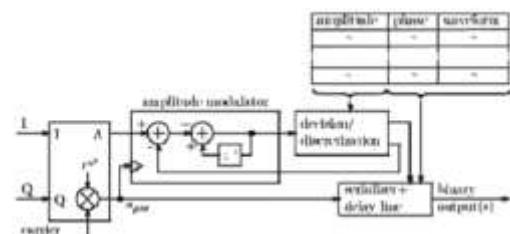

Figure 2. Modulator structure

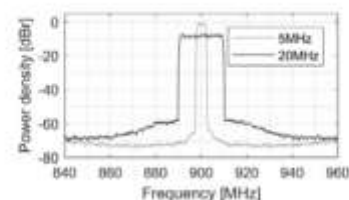

Fig 4: Modulator – Schematic

### 3. PROJECTED SYSTEM

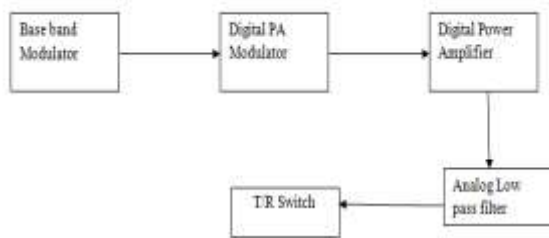

Fig 5: Diagram Skeleton of projected system

Analog low pass filter. They “filter-out” unwanted signals and a perfect filter can separate and pass curved input signals primarily based upon their frequency. This type of filter arrangement the sign Vin) is applied to the series combination (both the electrical device and condenser together) however the output (VOUT) is taken across the condenser solely.

### 4. SIMULATION RESULTS

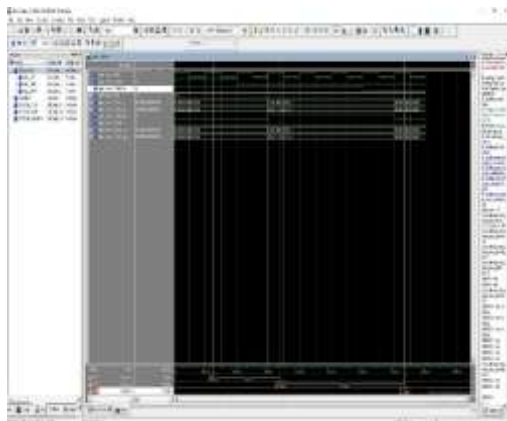

Fig 6. Time domain simulation result wave form

### 3. CONCLUSION

The operational principle and style techniques of digital amplifiers dissent greatly from those of analog PA ideas. Their inherent broadband properties open up new opportunities with reference to frequency gracefulness whereas still maintaining excellent potency. Moving the last a part of the bottom station’s transmitter chain into the digital domain is a vital step towards the absolutely software-defined radio, reduces size needs dramatically and makes the planning additional tolerant to producing variations than for analog amplifiers. The compactness brings any advantages therein the electronic equipment will be mounted directly behind every antenna component, even within the tightest antenna arrays for enormous MIMO applications. The ensuing elimination of cable losses contributes any to reduced energy consumption.

### REFERENCES

- [1] F. Hühn, A. Wentzel, W. Heinrich, A new modulator for digital RF power amplifiers utilizing a wavetable Approach, *Int. Journal of Microwave and Wireless Technologies*, vol. 9, no 6, pp. 1251-1260, Jul. 2017.
- [2] F. Hühn, A. Wentzel, W. Heinrich, GaN-Based Digital Transmitter Chain Utilizing Push-Pull Gate Drivers for High Switching Speed and Built-In DPD, *2017 IEEE European Microwave Conference Dig.*, Nuremberg, Germany, pp. 97-100, Oct. 2017.
- [3] T. Hoffmann, A. Wentzel, F. Hühn, W. Heinrich, Novel digital microwave PA with more than 40% PAE over 10 Db power back-off range, *2017 IEEE MTT-S Int. Microwave Symp. Dig.*, Honolulu, HI, USA, pp. 2037-2040, June 2017.
- [4] J.-C. Park, J.-G. Yook, B.H. Park, N. Jeon, K.-S. Seo, D. Kim, W.-S. Lee, C.-S. Yoo, Hybrid current-mode class-S power amplifier with GaN Schottky diode using chip-onboard technique for 955 MHz LTE signal, *IEEE Trans. MTT*, vol. 61, no 12, pp. 4168-4178, Nov. 2013.
- [5] M. Tanio, S. Hori, M. Hayakawa, N. Tawa, K. Motoi, K. Kunihiro, A linear and efficient 1-bit digital transmitter with envelope delta-sigma modulation for 700MHz LTE, *2014 IEEE MTT-S Int. Microwave Symp. Dig.*, Tampa, FL, USA, TU4F-2, June 2014.