

SELF DRIVING METRO TRAIN WITH POWER SAVING AND VIRTUAL ASSISTANT

Krishna Gupta¹, Diwakar Yadav², Deepa Gupta³, Krunal Raut⁴, Sheetal Mahadik⁵

^{1,2,3,4}Dept. of Electronics Engineering, Shree LR Tiwari College of Engineering, Maharashtra, India

⁵Professor, Dept. of Electronics Engineering, Shree LR Tiwari College of Engineering, Maharashtra, India

Abstract - Nowadays, Metro trains is in huge demand, as it covers the passenger journey within 10 to 15 minutes instead of 40 to 50 minutes due to huge traffics in the country. But current metro train works in the presence of driver due to which various problems occurs such as: human errors, delay of trains, flash strike, safety, overloading problem and no power saving features. So, to overcome this problem our team came up with self-driving metro train which will have power saving features and also a virtual assistant so that passengers can get their query solved, if they have any. So, in our project most of the role is performed using sensors. The heart of the whole system is the microcontroller namely Arduino Uno.

Key Words: Sensors, Power saving, Arduino uno, Chatbot, Proper timing, etc.

1. INTRODUCTION

The network of air-conditioned train serving the city is called Metro. It was started in 1984 in Kolkata.

The Kolkata Metro was the first metro railway in India, opening for commercial services.

Currently, 10 Indian cities have functional metro rail networks. These cities are Kolkata, Delhi, Chennai, Bengaluru, Hyderabad, Jaipur, Gurgaon, Mumbai, Kochi and Lucknow.

Still now passenger face problems like improper timing of train which is definitely due to human error as first service is not on time. Also, if there are two or more motorman sitting together, so they chat with each other and problems such as accident may occurs.

Also, as most of the metro trains works on bridge, so due to overloading of trains the strength of the bridge may get weak and in future there might be case of bridge collapsed, which may take loss of many passenger's life.

1.1 Arduino Uno

Arduino Uno is a microcontroller board of ATmega328 uc. It has a 14-digital input /output pin and also has a 6-analog pin and these 6 pins can also be used for PWM outputs. It has a 16 MHz ceramic resonator, a USB connection, a power jack and a reset button, the Arduino Uno open source as

microcontroller board based on the microchip of ATmega328 develop by Arduino.

The ATmega328 has 32 KB of memory with 0.5 KB used for the bootloader. It also has 2 KB of SRAM and 1KB of EEPROM which can be read and written with the EEPROM library. The Arduino Uno provides UART TTL (5V) serial communication, which is available on digital pins 0 (Rx) and 1 (Tx). The Arduino Uno can be programmed with the Arduino software. The maximum length and width of the Arduino Uno PCB are 2.7 and 2.1 inches respectively, with the USB connector and the power jack extending beyond the former dimension.

1.2 Ultrasonic Sensor

An ultrasonic sensor is an electronic device which can measure a distance of an object by emitting an ultrasonic wave like sound. Later it will convert the reflected sound into an electrical signal. Ultrasonic waves travel faster than the speed of audible sound. An Ultrasonic sensor uses transducer to send and receive ultrasonic pulses that relay back information about an object. So, in our project we are using ultrasonic sensor to detect presence of any obstacle coming in front of the train, so that when the ultrasonic sensor detects it, the train must stop. So, in this way in absence of a motorman the train can be stopped.

1.3 IR Sensor

An infrared sensor (IR) is an electronic device that is used to sense the different characteristics of its surroundings. It is used for emitting or detecting infrared radiation. It is used for measuring the signal by emitting and detecting of the objects. When IR lights of the same wavelength that are emitted by the IR LED. When IR lights falls on the photodiode and the resistance and the output voltages are change in proportion to the magnitude of the IR sensor. So, in our project we are using IR sensor to detect the presence of the platform and if the train senses the platform the speed of the train will gradually decreases and at the end passengers can enter or get out of the train.

1.4 Motor Driver

Motor driver which is type of an IC which allows a DC motor to drive on a particular direction. L293D is the name of motor driver we are using in our project. It is a 16 pin IC

which can control a set of two DC motor simultaneously in any direction. It means that it can control two DC motor with a single L293D IC. The output current capability is 600-mA per driver and its wide supply voltage range is 4.5V to 36V.

1.5 LDR

LDR stands for light dependent resistance. It is that kind of sensor used to measure the resistance decreases when light falls it and this kind of sensor are used in circuit for open area like e.g. lamp in LDR resistance that changes with the light intensity that falls upon it. In our project we have used LDR for power saving features whose working is as: initially in absence of any passengers there will be presence of sunlight so the internal resistance decreases with high amount of light present in environment, but as resistance is low so the output will be also low i.e. dim. On the other hand, if any passengers come in front of the LDR so the sunlight is blocked so in front of LDR darkness will be observed which will increase the internal resistance of LDR and the output will be high i.e. bright.

1.6 Virtual Assistant

We have built virtual assistant using a chatbot system which can be placed in each rake of the train using an LCD screen through which user can asked their queries related to train and the chatbot will provide the solution to their queries. We have use IBM Watson as a resource through which chatbot system is generated. Watson was created as a question answering computing system that IBM built to apply advanced natural language processing, information retrieval, knowledge representation, testing of the automated reasoning and machine learning technologies to the field of open domain question answering. Let us see the block diagram of a chatbot system.

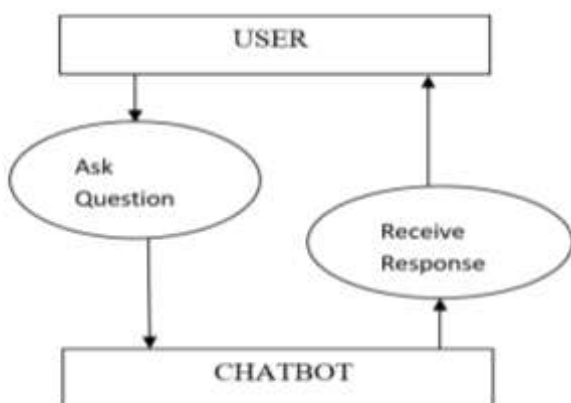

The output images of virtual assistant is as shown below:

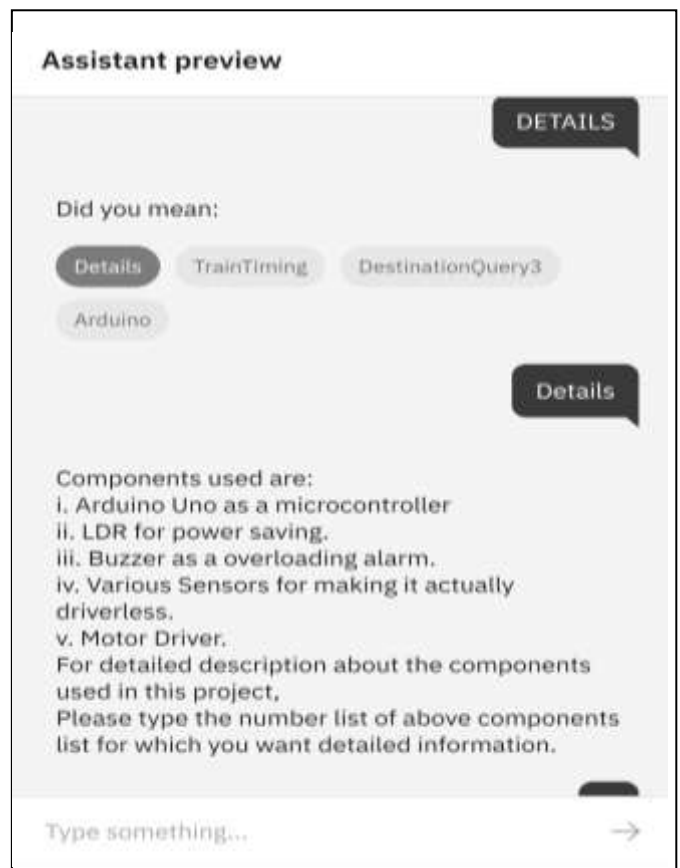
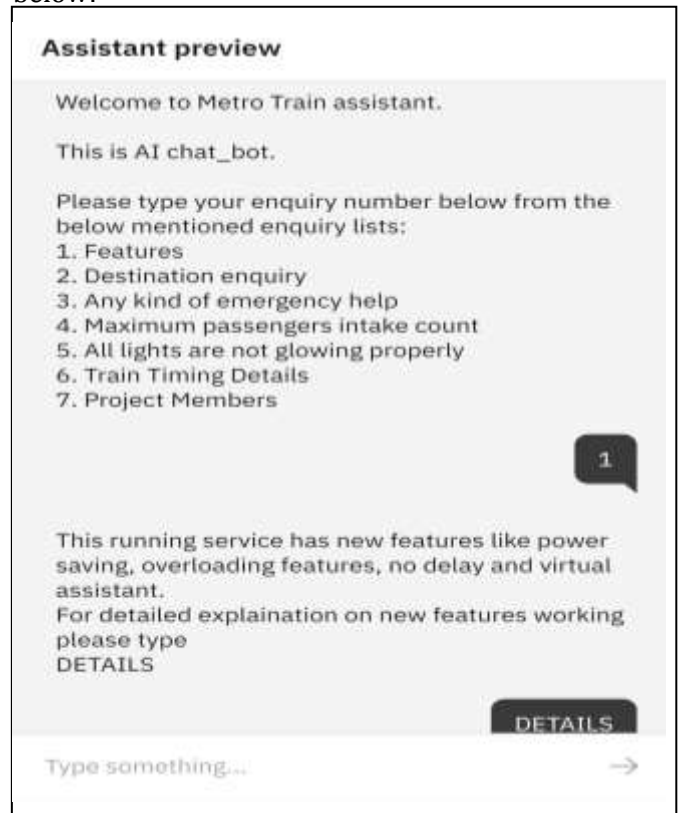

The output images of the self-driving metro train is as shown below:

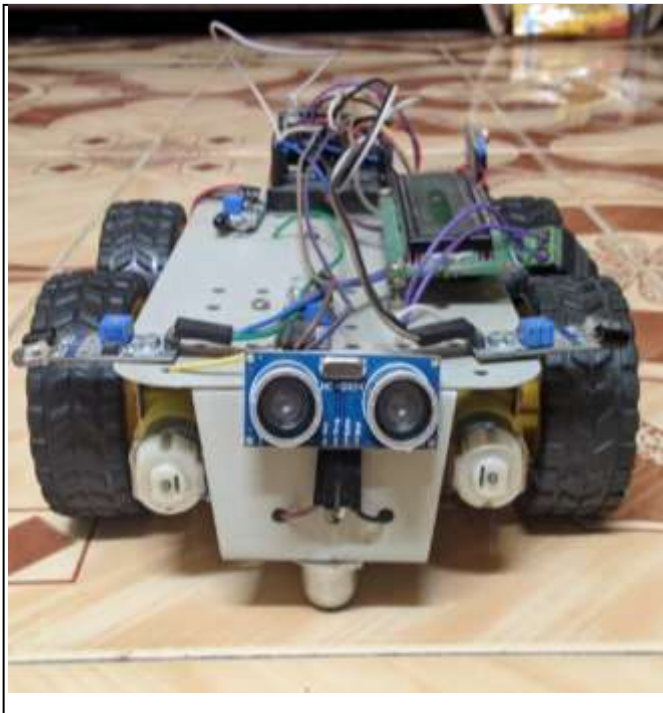

2. BLOCK DIAGRAM

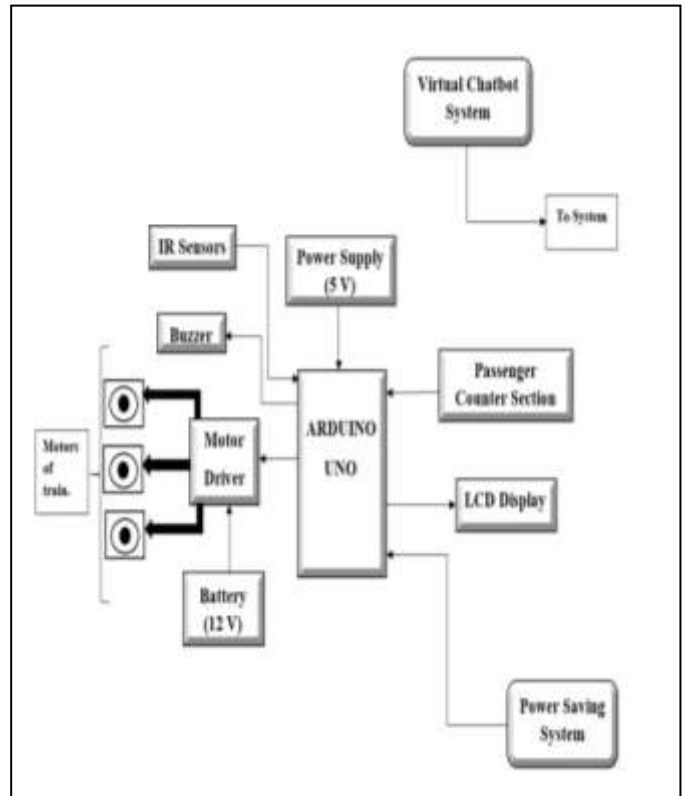

2. CIRCUIT DIAGRAM

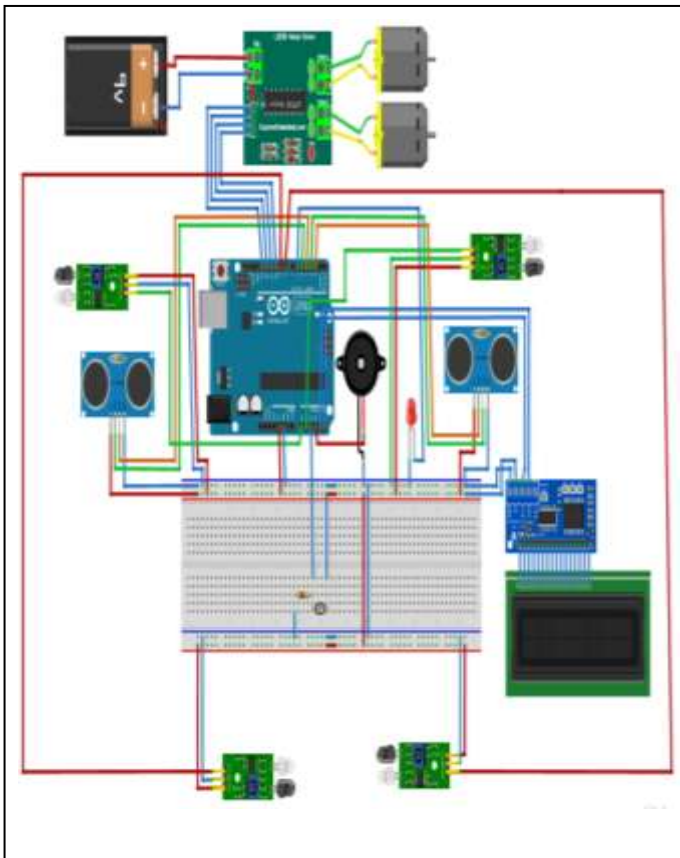

3. FLOW CHART

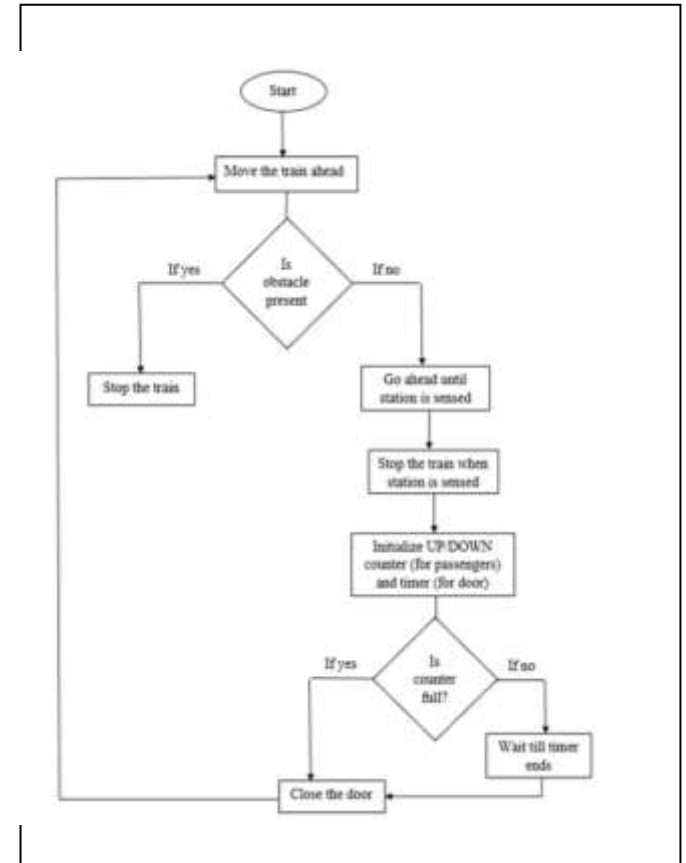

4. CONCLUSIONS

A driverless prototype is designed using Arduino Uno which consists of ATmega328 microcontroller that enables the automatic operation of the train from one stop to another. This system aims in reducing the human intervention in metro train as minimum as possible which in turn reduces the possibility of human error.

To avoid overloading of train, a sensor will be installed in each rake of train that will count the number of passengers present in the rake, if the number exceeds a particular threshold then an alarm will occur through buzzer indicating overloading of train in that particular rake.

The power saving feature is installed in each rakes of the train especially for lights saving so that even if there is no passenger in the train there is no use of unnecessary electricity and also if there are few passengers in the train then the lights will be ON around the passenger area only. Through this feature there is no need to install a switch in the train which need to be operated by passengers.

REFERENCES

- [1] Chavan Rohit Dnyaneshwar, Dabhade Swapnil Dilip, Kesbhat Amol Surendra, Nage Mohan Ramdas, Mrs. Gauri. K. Jagtap, "A survey paper on driverless metro train" IJARIE-ISSN(O)2395-4396 Vol-4 Issue-8 2018.
- [2] V.Sridhar "Automated System Design for Metro Train", International Journal of Computer Science Engineering. Vol 1 Sept 2012 pp. 30 - 41 Miryam Hernandez, "Metro automation: A proven and scalable solution," Euro Transport, Vol.12, pp.30-32, December.
- [3] Naga Swetha Yashwant, Badri Rabbani Basha "Auto Metro Train to Shuttle Between Stations", ISSN(PRINT):23938374: 2394-0697, VOLUME-5, ISSUE-4,2018.
- [4] Divyang Kaka, Harshad Sonawane, Hemang Jane, Abhishek Patel "Driverless Metro Train", IRJET Volume: 05 Issue: 03 | Mar-2018.