

Voltage Stability Improvement by using STATCOM

Maniyar Devalkumar¹, Dr. S.R. Vyas²

¹M.E. Student, Department of Electrical Engineering, KSV University, Gandhinagar, India

²Professor, Department of Electrical Engineering, KSV University, Gandhinagar, India

Abstract - The performance of power systems decreases with the size, the loading and the complexity of the networks. This is related to problems with load flow, power oscillations and voltage quality. Such problems are even deepened by the changing situations resulting from deregulation of the electrical power markets, where contractual power flows do no more follow the initial design criteria of the existing network configuration. Additional problems can arise in case of large system interconnections, especially when the connecting AC links are weak. FACTS devices, however, provide the necessary features to avoid technical problems in the power systems and they increase the transmission efficiency. This paper presents a study on the design of a shunt connected FACTS device (STATCOM) and investigates about the load flow study as well as the voltage stability during three phase fault with and without STATCOM to connect by connecting in electric power system. STATCOM is one of the key shunt controllers in flexible alternating current transmission system (FACTS) to control the transmission line voltage and can be used to enhance the load ability of transmission line and extend the voltage stability margin. In this paper, the proposed shunt controller based on the voltage source converter topology as it is conventionally realized by VSC that can generate controllable current directly at its output terminal. The performance and behavior of this shunt controller is tested in IEEE 5 bus system as well as the performance is compared in the test system with and without STATCOM at three cases in MATLAB/Simulink. Simulation results prove that the modeled shunt controller is capable to improve the Voltage Stability of Electrical power system.

Key Words: Voltage Stability MATLAB Simulation, STATCOM

1. INTRODUCTION

The performance of power systems decreases with the size, the loading and the complexity of the networks. This is related to problems with load flow, power oscillations and voltage quality. Such problems are even deepened by the changing situations resulting from deregulation of the electrical power markets, where contractual power flows do no more follow the initial design criteria of the existing network configuration. Additional problems can arise in case of large system interconnections, especially when the connecting AC links are weak. FACTS devices, however, provide the necessary features to avoid technical problems in the power systems and they increase the transmission efficiency. This paper presents a study on the design of a

shunt connected FACTS device (STATCOM) and investigates about the load flow study as well as the voltage stability during three phase fault with and without STATCOM to connect by connecting in electric power system. STATCOM is one of the key shunt controllers in flexible alternating current transmission system (FACTS) to control the transmission line voltage and can be used to enhance the load ability of transmission line and extend the voltage stability margin. In this paper, the proposed shunt controller based on the voltage source converter topology as it is conventionally realized by VSC that can generate controllable current directly at its output terminal. The performance and behavior of this shunt controller is tested in IEEE 5 bus system as well as the performance is compared in the test system with and without STATCOM at three cases in MATLAB/Simulink. Simulation results prove that the modeled shunt controller is capable to improve the Voltage Stability of Electrical power system.

2. BASIC CONFIGURATION OF STATCOM

The STATCOM is a shunt device. It should therefore be able to regulate the voltage of a bus to which it is connected. The operating principle of a STATCOM in this mode has been termed as the STATCOM in voltage control mode. In its most basic form, the STATCOM configuration consists of a VSC, a dc energy storage device; a coupling transformer connected in shunt with the ac system, and associated control circuits. Fig.1 shows the basic configuration of STATCOM. The VSC converts the dc voltage across the storage device into a set of three-phase ac output voltages. These voltages are in phase and coupled with the ac system through the reactance of the coupling transformer. Suitable adjustment of the phase and magnitude of the STATCOM output voltages allows effective control of active and reactive power exchanges have been made to recover the situation with solutions based between the STATCOM and the ac system. The VSC connected in shunt with the ac system provides a multifunctional topology which can be used for up to three quite distinct purposes:

- Voltage regulation and compensation of reactive power.
- Correction of power factor.
- Elimination of current harmonics.

As seen in Fig. 1, STATCOM is comprised of a coupling transformer, voltage based inverter and DC energy storage element. If it is a rather small capacitor, energy storage element can only be involved in reactive power exchange with the STATCOM line. If an accumulator or another DC voltage resource is used in the place of the DC capacitor, energy storage element can be involved in active and

reactive power exchange with the transmission system. The voltage amplitude of the output and phase angle of STATCOM can be changed. The amplitude of AC output voltage basic component of an inverter can be controlled as $V_0 = m_a V_{dc}$. Here, m_a is the modulation index [10-12].

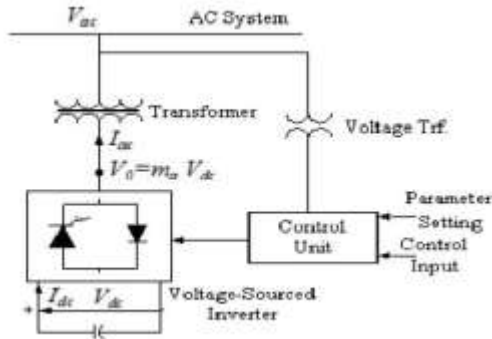

Fig.1. STATCOM circuit diagram

3. Principle of STATCOM:

STATCOM is to suppress voltage variation and control reactive power in phase with system voltage. It can compensate for inductive and capacitive currents linearly and continuously. Fig.3 shows the vector diagram at the fundamental frequency for capacitive and inductive modes and for the transition states from capacitive to inductive and vice versa. The terminal voltage (V_{bus}) is equal to the sum of the inverter voltage (V_{VSC}) and the voltage across the coupling transformer reactive V_L both capacitive and inductive modes. It means that if output voltage of STATCOM (V_{VSC}) is in phase with bus terminal voltage (V_{bus}) and V_{VSC} is greater than V_{bus} , STATCOM provides reactive power to system. If V_{VSC} is smaller than V_{bus} , STATCOM absorbs reactive power from power system. V_{bus} and V_{VSC} have the same phase, but actually they have a little phase difference to component the loss of transformer winding and inverter switching, so absorbs some real power from system.

STATCOM vector diagrams, which show inverter output voltage V_I , system voltage V_T , reactive voltage V_L and line current I in correlation with magnitude and phase δ . Fig.3 a and b explain how V_I and V_T produce capacitive or inductive power by controlling the magnitude for inverter output voltage V_I in phase with each other. Fig.3 c and d show STATCOM produces or absorbs real power with V_I and V_T having phase $\pm\delta$. The transition from inductive to capacitive mode occurs by changing angle δ from zero to a negative value. The active power is transferred from the AC terminal to the DC capacitor and causes the DC link voltage to rise.

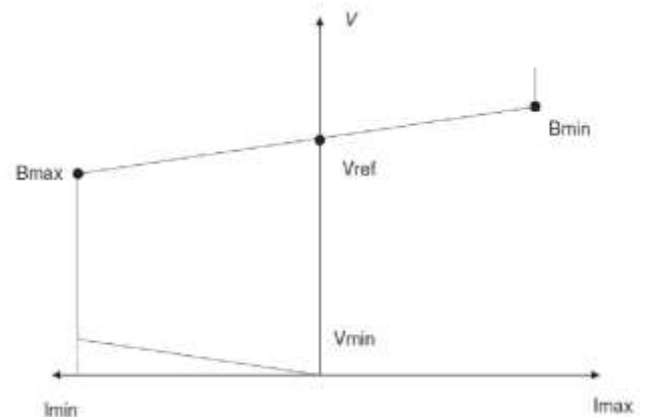

Fig. 2. V-I Characteristics of STATCOM

4. Simulation Result:

The single line diagram of IEEE-5-Bus network is shown in Fig.3. The transmission line parameters, generation, and loads are given in per unit value.

The network details are:

Number of lines = 7, Number of buses = 5, Number of generators = 2, and Number of loads = 4.

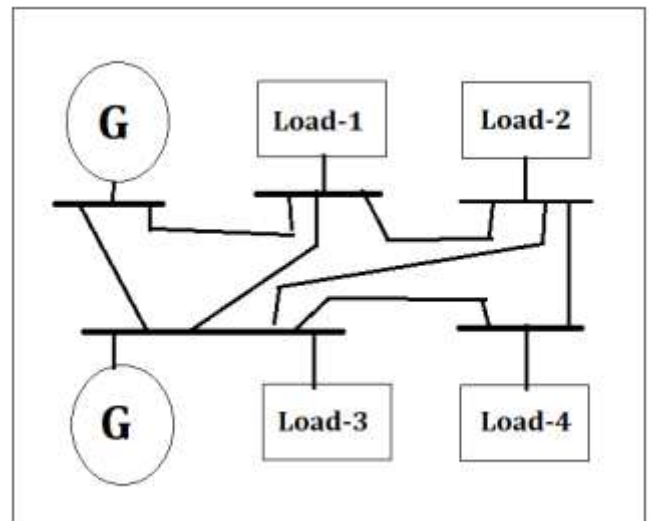

Fig. 3 IEEE 5 Bus System Single Line Diagram

Matlab Simulation Circuit diagram of IEEE 5 Bus System is shown in fig. 4.

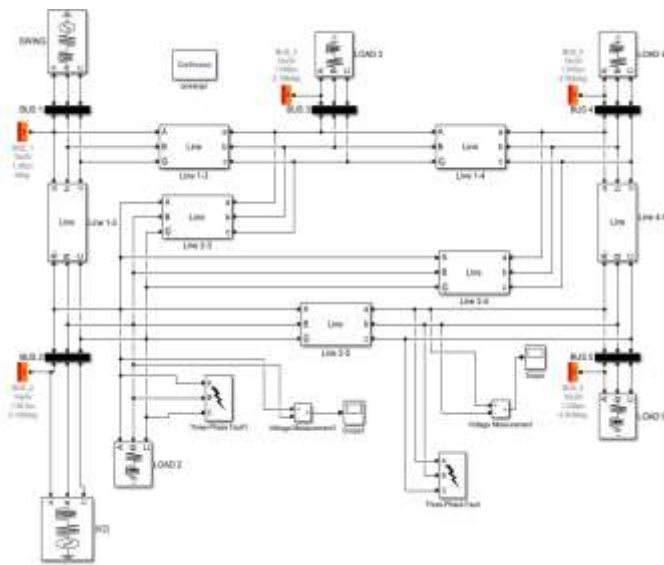

Fig. 4 IEEE 5 Bus system without STATCOM

Table: 1 Bus Data, IEEE 5 Bus System

Bus No.	Voltage Magnitude	Load MW	Load MVR	Gen MW	Gen MVAR	Q min	Q max
1	1.06	0.0	0.0	0.0	0.0	-600	600
2	1	20.0	10.0	40.0	0.0	-300	300
3	1	46.0	16.0	0.0	0.0	0.0	0.0
4	1	40.0	06.0	0.0	0.0	0.0	0.0
5	1	60.0	10.0	0.0	0.0	0.0	0.0

Table: 2 Line Data for IEEE 5 Bus system

Bus No.	Bus No.	R	X	B
1	2	0.02	0.06	0.06
1	3	0.08	0.24	0.05
2	3	0.06	0.18	0.04
2	4	0.06	0.18	0.04
2	5	0.04	0.12	0.03
3	4	0.01	0.03	0.02
4	5	0.08	0.24	0.05

Load flow study using MATLAB/SIMULINK has been carried out and load flow data were tabulated for the analysis of voltage stability and loss minimization and also accordingly the optimal location of STATCOM is determined.

Table: 3 Load Flow Data For IEEE 5 Bus system

STATCOM Location	Bus 1	Bus 2	Bus 3	Bus 4	Bus 5
	V(pu)	V(pu)	V(pu)	V(pu)	V(pu)
Bus 1	1.05	1.025	1.001	0.992	0.947
Bus 2	1.05	1.029	1.003	0.993	0.949
Bus 3	1.05	1.028	1.006	0.994	0.950
Bus 4	1.05	1.026	1.003	0.996	0.950
Bus 5	1.05	1.027	1.005	0.995	0.952

Table 3 it can be seen that the variation of voltage magnitude and load angle at different buses according to the location of STATCOM. The Orange highlighted at bus3 indicates the least stable condition as the voltage magnitude changes more when STATCOM installed at bus3. Similarly bus5 is red highlighted because when STATCOM is at bus5 the voltage magnitude variation is less as compared to others and it is the location of most stable in this five bus system.

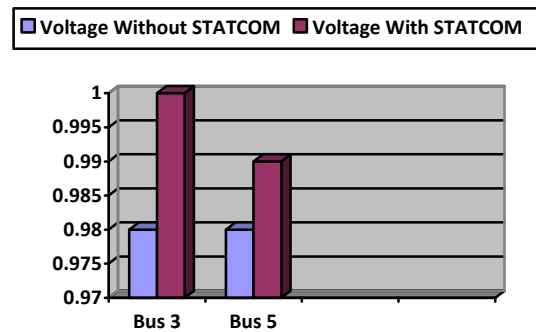

Fig. 5 Graphical Representation of Improvement Voltage Profile by using SATCOM

5. CONCLUSION

This paper has presented the stability improvement of a generator, rotor angle deviation connected to power system. A STATCOM is proposed and is connected to the same bus with the transmission line. It can be concluded from the simulation results that the proposed STATCOM can be used to improve the performance of the voltage stability, transient stability, rotor angle deviation, transmission line to power grid under different operating conditions.

REFERENCES

- [1]. Yasoda Kailasa Gounder ,Devarajan Nanjundappan, Veerakumar Boominathan, "Enhancement of transient stability of distribution system with SCIG and DFIG based wind farms using STATCOM" IET Renewable Power Generation, 16th June 2016
- [2]. S. M. Muyeen, " A Combined Approach of Using an SDBR and a STATCOM to Enhance the Stability of a Wind Farm" IEEE systems journal, vol. 9, no. 3, September 2015
- [3]. Haizea Gaztañaga, Ion Etxeberria-Otadui, Dan Ocnasu, and Seddik Bacha, " Real-Time Analysis of the Transient Response Improvement of Fixed-Speed Wind Farms by Using a Reduced-Scale STATCOM Prototype" IEEE transactions on power systems, vol. 22, no. 2, may 2007
- [4]. Shenglong Yu, Tyrone Fernando, Tat Kei Chau, and Herbert Ho-Ching Iu, " Voltage Control Strategies for Solid Oxide Fuel Cell Energy System Connected to Complex Power Grids Using Dynamic State Estimation and STATCOM", IEEE transactions on power systems, vol. 32, no. 4, july 2017
- [5]. Saeed Arabi, Hamid Hamadanizadeh, and Behruz (Bruce) Fardanesh, "Convertible Static Compensator Performance

- Studies on the NY State Transmission System” IEEE transactions on power systems, vol. 17, no. 3, august 2002
- [6]. Rabiah Badar, Saad Dilshad, “Neuro Fuzzy Wavelet Control for Power System Stability Enhancement using STATCOM” IEEE 2016
- [7]. Siva Kumar Balibani, Gurunath Gurralla, Indraneel Sen, “Power System Stability Enhancement Using A STATCOM with ESS”, 2013 Annual IEEE India Conference (INDICON).
- [8]. Kazuhiro Kobayashi, Masuo Goto, Kai Wu, Yasunobu Yokomizu and Toshiro Matsumura, “Power System Stability Improvement by Energy Storage Type STATCOM”, 2003 IEEE Bologna PowerTech Conference, June 23-26, Bologna, Italy
- [9]. Ghazanfar Shahgholian, Saeid Fazeli-Nejad, “Power System Oscillations Damping by Optimal Coordinated Design Between PSS and STATCOM Using PSO and ABC Algorithms”, IEEE 2016
- [10]. Li Wang, Che-Hao Chang, Bing-Lin Kuan, and Anton V. Prokhorov, “Stability Improvement of a Two-Area Power System Connected With an Integrated Onshore and Offshore Wind Farm Using a STATCOM”, IEEE transactions on industry applications, vol. 53, no. 2, March/April 2017