

Intelligent Shopping Cart and Economic Analysis using IoT and Cloudserver

Under the guidance of Mrs. R. Krishnaveni

Submitted by

Sruthi.P.S, Shanmathi Anu Radha.S

Department of ECE, Panimalar Institute of Technology, Chennai, Tamil Nadu

Abstract-A shopping centre or departmental store or supermarket is a place where consumers like us purchase many products for our day to day usage. So usually all of us have to wait in long queues to get our products scanned using barcode scanner and get it billed. To overcome this problem, we have proposed a new 'Intelligent shopping cart and economic analysis (based on IOT) using cloud server'. This overall design is used to assist people when they are shopping and it avoids standing in long queues and thus it saves time. Our intelligent shopping cart has Microcontroller and Reader/scanner and it is also useful in economic analysis. The products in the shopping centres will have particular tags to access the product information. When a customer places a product in the cart, the reader will scan and read the ID of the each product and the information related to those products will be stored in micro controller. The total amount of the products we purchased will be calculated and will be updated on the cloud server for further references.

Keywords- Cloud server, Microcontroller, Reader, RFID tags

INTRODUCTION

Many of us tend to buy products in shopping centres or departmental stores or super markets. One of the major inconvenience faced is we follow queues which consumes lot of time even when we buy one or two products. Also, when it comes to shopping, people generally overshoot their budget and this happens generally in supermarkets. Also, they end up in waiting for the products to be checked, scanned and billed. So in order to maintain the predefined budget, we can use this intelligent shopping cart. The core idea of this project is to automate the traditional billing process so as to eliminate the manpower and the time consumed. The shopkeepers are ready to welcome such smart machines that automate the billing process. So we decided to incorporate this automatic billing concept in our cart rather than waiting in the queue even for one or two products. Customers can pay their bills through the pre recharged cards provided by the shop. This project makes the traditional way of billing completely automated and it is user friendly and much easy to use.

RELATED WORK

THEIR PROPOSED DESIGN AND IMPLEMENTATION OF A SMART SHOPPING CART BY RFID TECHNOLOGY
by NEMALIDINNE SAI MEGANA

According to this work, in the recent days people purchase a variety of items and put them in the trolley.

After the entire purchase one should approach counter for billing purpose. By using barcode reader the person working in the supermarket = prepares the bill which is actually a time consuming process. This results in quiet a huge queues at the billing counters. This project presents an idea to develop a smart system in shopping malls to overcome all the above problems. To achieve this all the products in the mall should be equipped with RFID tags and all trolleys should consist with a RFID reader and LCD screen individually. When the customer puts any product in the trolley its code(will be predefined) will be detected automatically, the item name and cost will be displayed on the LCD, thereby the cost gets added. If we wish to delete the product from the smart trolley, you can take away the product and the amount of that particular product would get deducted from total amount and that particular information will get passed to the central billing unit via zigbee module. Hence the billing can be done in the trolley itself thus it saves time.

PROPOSED SYSTEM DESIGN

Our intelligent cart consists of few major components namely the reader/scanner, tags, and four buttons(Add, Delete, Reset and Checkout). Whenever the customer drops the products they want to buy in the cart, the reader/scanner present in our intelligent cart will scan and read the individual unique tag number of the product. After our product gets scanned, the reader/scanner reads the particular product data information from the microcontroller, because the

microcontroller has been already stored with product details. We have to press the add button when we want to add any products and the amount of the products which we purchase one by one will be added and the total amount will be calculated. We can also delete the items purchased, by pressing the add button once again(odd numbers-adding, even number- deleting) and by scanning the tag of that particular item which you don't want. After purchasing all the products we require, we have to press the checkout button. Once the checkout button is pressed, the bill for the purchased products will be generated. To pay the bill we have to read the payment tag to the RFID reader which will deduct the bill amount from that card. After all this process and once the payment is done, the datas will be uploaded to the cloud for future references and maintenance.

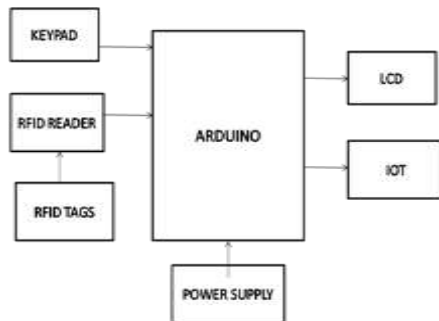

Fig 1. System Overview

Microprocessors based – Can be microprocessor or microcontroller.

Memory – Should have a memory, because its software generally embeds in ROM and it does not need any secondary memory.

Connected–The peripheral should be connected so as to connect input and output devices.

HW-SW systems – Software for features and flexibility. Hardware for performance and security

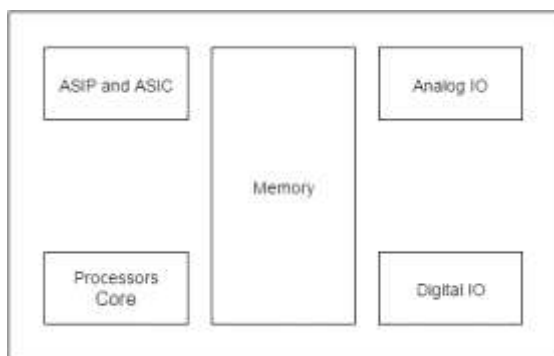

ARDUINO



Arduino microcontrollers are already pre-programmed with a boot loader and it uploads the programs to the on-chip flash memory in a easier way. The default bootloader of the UNO is the optiboot bootloader.

Serial Arduino boards usually contains a level shifter circuit to convert between RS-232 logic levels and transistor-transistor logic (TTL) level signals. The present Arduino boards are programmed through the Universal Serial Bus (USB)

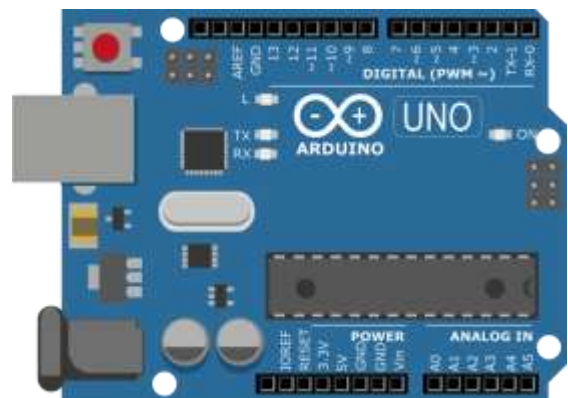

PROGRAMMING

The Arduino Uno can be used to be programmed with the Arduino Software(IDE). Select "Arduino/Genuino Uno" from Tools > Board (according to the microcontroller on your board). The ATmega328 on the Arduino/Genuino Uno comes already programmed with the bootloader and it allows you to upload new code to it without the use of an external hardware programmer. The overall communication takes place using the original STK500 protocol.

The bootloader can be bypassed and the microcontroller can be programmed through ICSP (In-Circuit Serial Programming) header using Arduino ISP.

The ATmega16U2 firmware source code (or it can be 8U2 in the rev1 and rev2 boards) is readily available in the Arduino repository.

The ATmega16U2/8U2 should be loaded with a DFU bootloader, which can be further activated by:

Rev1 boards: connecting the solder jumper on the back of the board which is present near the map of Italy and then resetting the 8U2.

- Rev2 or later boards: Here is a resistor which pulls the 8U2/16U2 HWB line to ground and make it easier to put into DFU mode.

Atmel's FLIP software(Windows) or the DFU programmer(Mac OS X and Linux) can be used in order to load a new firmware. You can also use the ISP header with an external programmer (which overwrites the DFU boot loader).

RFID READER AND TAG

An RFID reader is a device that is used to question a RFID tag. The reader contains an antenna which emits the radio waves; the tag responds by sending its data back after receiving.

An RFID tag is a combination of the microchip and an antenna in a compact package. the packaging is structured and it allows the RFID tag to be attached to an object which isto be tracked. The full form in "RFID" the Radio Frequency Identification. The antenna of the tag picks up signals from an RFID reader and then returns the signal with some additional data (say for eg- unique serial number or other customized information).

RFID

Few operations are mentioned below

Tags: A tag is a data carrier and normally consists of the ID number, and unique EPC code programmed in the tag

Tag Antenna: This antenna is connected to the chip in tag. It could be a wire or can be printed using conductive ink.

Reader Antenna: It is the coil included in plastic or similar case, and normally is of this particular measurement (12-18 inches square)

Reader: A reader holds the data provided by the tag within the detectable area of the reader or scanner. There can be one or **more tags within the area. A reader is generally** capable of reading multiple tags in the same time.

Savant: This is generally the middleware which interacts with the readers and communicates with External databases

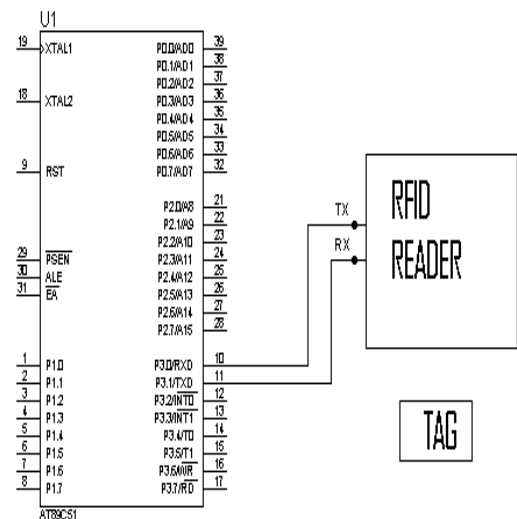
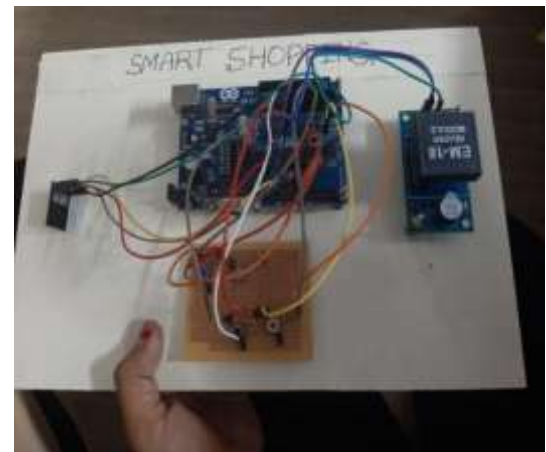
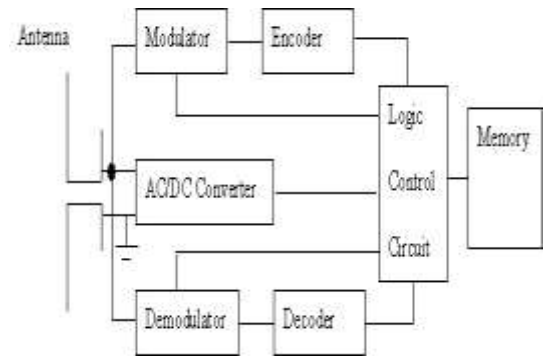

INTERNET OF THINGS(IOT)

Internet of Things (IoT) is a platform in which objects, animals or people are provided with unique identifiers and they have the capability of transferring data over a network without requiring human-to-human or human-to-computer interaction/communication. Data may be updated to a particular site or a social network by which the user can able to access the data.

ESP-12E- This is the WiFi module developed by Ai-thinker Team. The core processor ESP8266 is smaller in sizes of the module and it encapsulates Tensilica L106 and integrates the industry-leading ultra low power 32-bit MCU micro, with the 16-bit short mode, Clock speed support 80 MHz, 160 MHz, supports the RTOS, Wi-Fi MAC/BB/RF/PA/LNA, on-board antenna.

This module is supported by the standard IEEE802.11 b/g/n agreement, complete TCP/IP protocol stack. Users can also use the add modules to an existing device networking, or to build a separate network controller. ESP8266 is high integration wireless SOCs, which is designed for space and power constrained mobile platform designers. ESP8266EX gives a clear Wi-Fi networking solution and it can also be useful in hosting the application or in unloading Wi-Fi network functions from another application processor.

When the processor ESP8266EX hosts the application, it boots up from an external flash directly. It consists of integrated cache to increase the performance of the system.

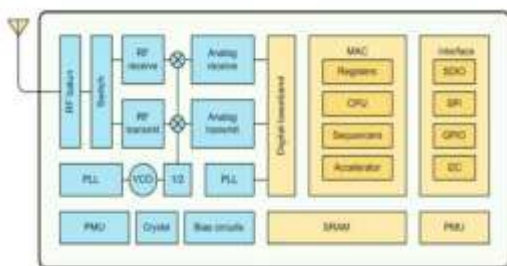

Figure 1 ESP8266EX Block Diagram

RESULT

The result of our project: Our project is completely automated and it saves time for the customers and makes the process easy for the shopkeepers. It avoids large queues and makes the entire process simple. It reduces one third of the overall investment of the shopkeeper for the billing department. Thus this project would definitely give better shopping experience using the advanced technology.

CONCLUSION

According to the customer's point of view, our project has redefined the way of purchasing. RFID has outsmarted barcodes by its accuracy and faster response. Our concept has eliminated the traditional and inefficient way of billing. Future advancement of this project involves usage of enhanced RFID readers that operate in high frequency which can read multiple tags at the same time.

REFERENCES

- Gubbi, J., Buyya, R., Marusic, S., Palaniswami, S.: Internet of Things (IoT): a vision, architectural elements, and future directions. IEEE (2011). <https://doi.org/10.1109/i-smac.2017.80583992>.
- Gangwal, U., Roy, S., Bapat, J.: Smart shopping cart for automated billing purpose using wireless sensor networks. IEEE (2013). <https://doi.org/10.1109/icices.2014.7033993>.
- Yathisha, L., Abhishek, A., Harshith, R., Darshan Koundinya, S.R., Srinidhi, K.: Automation of shopping cart to ease queue in malls by using RFID (2015). <https://doi.org/10.1109/icices.2014.70339964>.
- Kaur, A., Garg, A., Verma, A., Bansal, A., Singh, A.: Arduino based smart cart. Int. J. Adv. Res. Comput. Eng. Technol. (IJARCET) 2(12) (2013)
- Dash Robotic Shopping Cart. <https://www.fastcompany.com/3061405/walmart-is-testing-a-robot-shopping-cart-so-you-can-do-the-job-of-low-wage-workers>
- Sanghi, K., Singh, R., Raman, N.: The Smart Cart –An Enhanced Shopping Experience. TA:Justine Fortier Team 41 (2012)
- Dubey, V., Sangeeth Sagar, V.R., Sumalya, S., Abhilash, C.B.: An Android approach for wireless power harvesting from radio waves. In: Contemporary Computing and Informatics (IC3I), pp. 1235–1239. IEEE (2014).
- Galande Jayashree, Rutuja Gholap, Priti Yadav on “RFID based Automatic billing trolley” year - 2015, publication IJETA E
- Sainath, K., Surendra, V., Vikram, Arvind on “Automated smart trolley integrates Raspberry Pie embedded chip with two barcode scanners used in supermarket”, year-2014, publication-ICCCMIT
- Mr. Yathisha L, Abhishek A, Harshit R, Drashal Koundinya on “Automation of shopping cart to ease queue in malls by using RFID”, year-2015, publication-IRJET
- Jadhav Rahul, Pradeep, Nandkumar, Tarali Shivkumar “RFID based Automated billing trolley”, year-2015, publication IJSRD