

# FABRICATION OF PNEUMATIC SHEET METAL SHEARING MACHINE

K Uday Kiran<sup>1</sup>, V Naga Durga Ranjith<sup>2</sup>, MD Rizwan Pasha<sup>3</sup>, V.Vineela<sup>4</sup>, Shaik Ismail<sup>5</sup>, R Raj Kumar<sup>6</sup>, Y Thomas Nikhil<sup>7</sup>

<sup>1</sup>Assistant Professor, Department of Mechanical Engineering DMSSVH college of engineering, Machilipatnam, Andhra Pradesh, India

<sup>2</sup>BTech Student, Department of Mechanical Engineering DMSSVH college of engineering, Machilipatnam, Andhra Pradesh, India

\*\*\*

**Abstract** - Normally the sheet metal cutting machine is manually hand operated for medium and small scale industries. This paper gives an insight about the automatic sheet metal cutting machine. Any automatic machine aimed for economical use of man. In this paper, Pneumatic cylinder is used for cutting in easy way which can be used in small scale industries at lower cost. The sheet metal cutting machine works with the help of pneumatic double acting cylinder. The piston is connected to the moving cutting tool which is used to cut the sheet metal. The cutting process is operated by a direction control valve by using compressor. In manual method sheet metals goes to sharp sometime because of wrong dimensions, improper cutting etc. Hydraulic machines are also used for sheet metal cutting. But these machines are used for heavy metal cutting and its cost is very high. Hence, we are using a pneumatic system for sheet metal cutting in a easy manner. The main advantage of pneumatic sheet metal cutting machine is to improve product quality, repetition of work and increasing production rate.

**Key Words:** pneumatic Cylinder, Control Valve, Compressor, Sheet metal.

## 1.INTRODUCTION

The sheet metal shearing machine is the heart of sheet metal industries. In some industries, hand sheet cutter is used which is operated manually. In these machine, we are using pneumatic cylinder for sheet metal cutting. These machine should be easy to operate and maintain also. Hence, we are introducing a pneumatic sheet metal cutting machine which will reduce manufacturing cost and minimize industrial labor problems which is the biggest headache for human. The main objective of our project is perform job holding operation effectively with less human efforts by using a machine with the pneumatic power. This will also reduce the time required for metal cutting. By using these machine we can increase the production rate and automatically the industry will be in profit. Automation plays an important role in mass production. Automation can be achieved through pneumatic form. The main advantage of pneumatic system is economically cheap and easy to handle. The

manufacturing operation is being atomies for the following reasons.

- To reduce human efforts
- To increase production rate
- To increase efficiency of industry
- To reduce the work load
- To reduce production time

## 2. LITERATURE REVIEW

In cutting operation as or blade descends upon the metal, the pressure exerted by the blade first caused the plastic deformation of the metal, since the clearance between to blade is very small. The plastic deformation of the metal, since the clearance between to blade is very small. The plastic deformation takes place in localise area and the metal adjacent to the cutting edges of the blade edges become highly stress, with courses the fracture to start on both side of the sheet as the deformation progresses and sheet is shear.

Types of shearing machines:

- Pneumatically operated
- Hydraulically operated
- Rack and pinion operated
- Spring operated

### 2.1 PNEUMATICALLY OPERATED

Here is the advancement of the header which is carried out in the upward and downward direction using the pneumatic double acting piston and cylinder unit arrangement along with the foot operated direction control valve. In this type of machine high pressure air is used as the working fluid for the transfer of power and the motion.

## 2.2 HYDRAULICAY OPERATED

Here the lowering and rising of the header which is carried over using the hydraulic piston and cylinder arrangement. To actuate the piston and cylinder, the oil is allow to enter the cylinder for front or backside of the piston. But the oil is comparatively cost layer and it is leakage may cause so many problems.

## 2.3 RACK AND PINION OPERATED

Here the lowering and raising of the header carried out manually using rack and pinion arrangement. In this case the required pressure is applied manually using direct hand pressure on the rack using pinion and lever arrangement. Since the machine robust and required large pressure, hence it is not suitable.

## 2.4 SPRING OPERRATED

The working of spring operated machine is similar to rack and pinion operated machine but differs for it in construction. Here the lowering and the raising of the heating handle are carried out manually and it required too much pressure for its operation also there possibility to having damage to the work if not handled carefully.

## 3. CONSTRUCTION

### A. Raw material used-

- 1) Cast iron bar for base frame
- 2) High speed steel for shearing blade
- 3) Cylinder fitting like fork end, base plate, support link
- 4) Angle section for blade fitting
- 5) Connecting link
- 6) Blade link

### B. Ready items used-

- 1) Pneumatic double acting cylinder
- 2) Direction and flow control valve
- 3) Pneumatic pipe and pipe fitting
- 4) Bold and nuts
- 5) Paint

### C. Machine and tool used Machine and tools used-

- 1) Cutting machine
- 2) Welding machine
- 3) Hacksaw cutting machine
- 4) Radial drilling machine
- 5) Grinder
- 6) Hand grinder

7) Screen holder

8) Hammer

### D. Specification-

- 1) Pneumatic cylinder-
  - Quantity: 1
  - Total length: 510mm
  - Bore diameter: 80mm
  - Piston rod diameter: 20mm
  - Maximum working pressure: 10bar
  - Weight: 3kg
- 2) Pneumatic pipe-
  - Quantity: 1
  - Diameter: 10mm
  - Thickness: 2mm
- 3) Direction and flow control valve-
  - Quantity: 1
  - Operation: manual
  - Type: hand lever
  - Number of ports: 5
  - Number of positions: 3
  - Construction: sliding spool type
- 4) Fork end nut-
  - Quantity: 2
  - Length: 16mm
  - Size: M16
- 5) Cylinder base plate bold-
  - Quantity: 4
  - Length: 64mm
  - Size: M6
- 6) Blade fixing bold-
  - Quantity: 3
  - Length: 125mm
  - Size: M12

## 4. COMPONENTS



**Chart -1:** Pneumatic sheet metal shearing machine

#### 4.1 PNEUMATIC CYLINDER

Double acting cylinder are equipped with two working ports on the piston side and the other on the rod side, to achieve forward motion of the cylinder, compress air is admitted on the piston side and rod side is connected to exhaust, during return motion supply air admitted at the rod side while the piston side volume is connected to the exhaust, force is exhausted by the piston both during forward and return motion of cylinder.

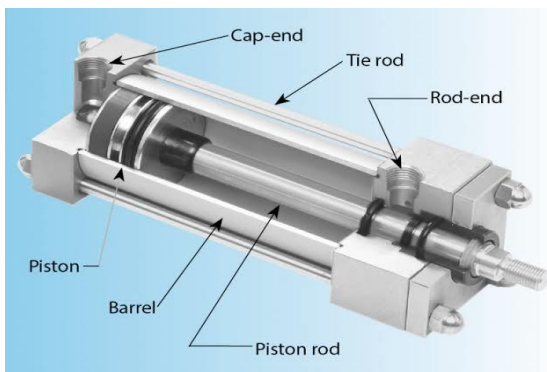

Chart -2 : Pneumatic Cylinder

#### 4.2 DIRECTION CONTROL VALVE

A control valves are used to reduce the rate of flow in a section of a pneumatic circuit, resulting in a slower actuator speed. Unlike a needle valve, a flow control valve regulates air flow in only one direction, allowing free flow in the opposite direction. A control valve is a valve used to control fluid flow by varying the size of the flow passage as directed by a signal from a controller this enables the direct control of flow rate and the consequential control of process quantities such as pressure, temperature and liquid level. Air control valves are fundamental components of any pneumatic system. Selecting the right air control valves to regulate system pressure, direction of flow, and rate of flow is crucial when designing fluid power circuitry. If the pneumatic valve is too big for your application, you will be wasting air in money.



Chart -3: Direction Control Valve

#### 4.3 HIGH SPEED CUTTING BLADE

Sheet metal is a metal form by an industrial process into think, flat pieces it is one of the fundamental forms used in metal working and it can be cut and bend every day object are fabricated form sheet metal.

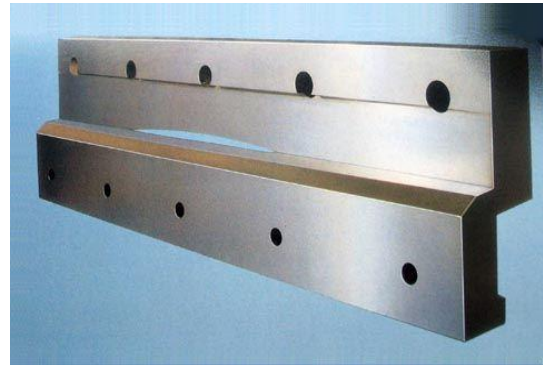

Chart -4 : High Speed Cutting Blade

#### 4.4 AIR COMPRESSOR

Air compressor is a device that convert power ( using an electric motor, diesel or gasoline engine etc ) into potential energy stored pressurize air ( that is, compress air), by one of several method and air compressor force more and more air into storage tank, increasing the pressure, when tank pressure reaches is upper limit the air compressor shuts off the compress air, then, held in the tank until called into used.



Chart -5: Air compressor

## 5. WORKING PRINCIPLE

The following figure shows general layout for the machine

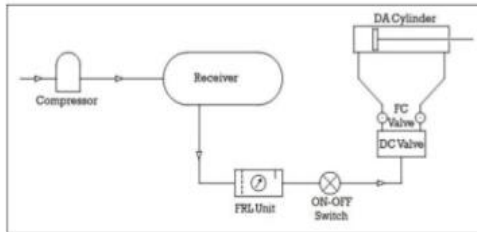
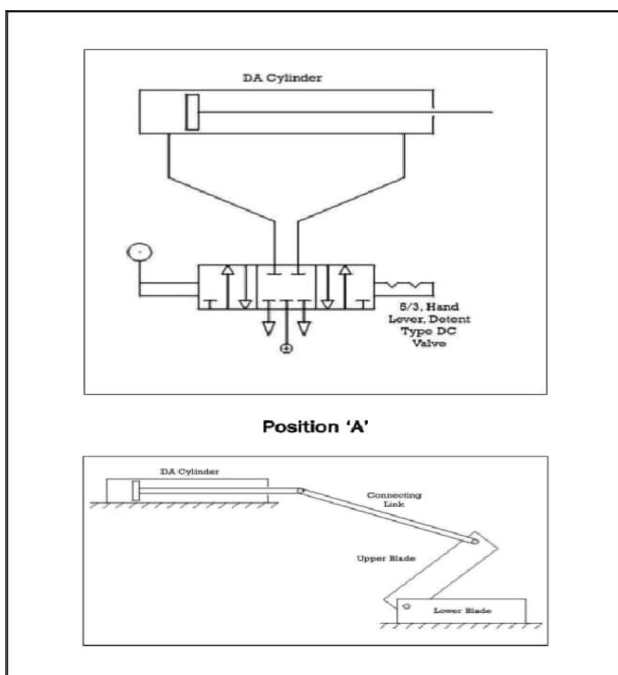

Figure: General Layout

Initially the air the air compressor is started and allowed the receiver tank air pressure to reach up to 8 bar. The supply air is then passed to the manifold through FRL unit to condition the air and eligible to industrial use.

From the manifold a separate supply for the machine is taken out and given to ON-OFF switch, so as to operate the machine at will without interrupting the running of compressor.

Then the pipe carries compressed air first to machine's Direction Control Valve. At position 'A' shows the non-actuated Circuit Diagram. At this position the piston is steady and locked. All ports are in closed condition.



At position 'B', the DC valve is at left hand position as shown in figure. The cap end port & pressure port get connected to each other and the rod end port gets connected to each other and the rod end port gets connected to the exhaust port. The compressed air comes in the cap end of the cylinder and pushes the pistons outwards. The air already present in the rod end side is pushed out of the cylinder.

When the piston moves outwards, the force is transmitted through the connecting link and the upper blade moves downwards. Before the actuating DC valve the sheet is inserted in between the upper & lower blades. As upper blade moves downwards, the stress is generated in the sheet metal and goes beyond ultimate shear stress of sheet metal. And thus the shearing action takes place.

Now the DC valve is operated to come at piston 'C' as shown in figure. The rod end port & pressure port get connected to each other and the cap end port gets connected to the exhausted port. The compressed air comes in the rod end of the cylinder and pushes the pistons inwards. The air already present in the cap end side is pushed out of the cylinder.

The sheet metal is either again inserted for further cutting in case of large pieces; the small cut pieces are removed and the next sheet is inserted to cut.

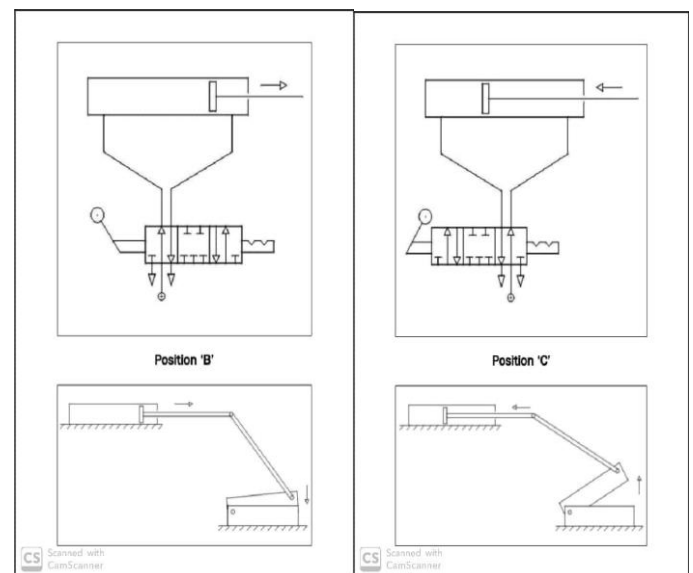

## 6. ADVANTAGES

1. Hydraulics present certain advantages over pneumatics, but in a given application, pneumatic powered equipment is more suitable, particularly in industries where the factory units are plumbed for compressed air.

2. Moreover, to avoid corrosive actions, oil or lubricants are added so that friction effects can be reduced.

3. Compressed air is used in most of the machines and in some cases compressed carbon dioxide, whereas cutting process is become easy.

4. Fast cutting action is carried out.

5. Cutting without bending is achieved.

### 7. DISADVANTAGES

1. Sheet more than 2mm thickness can't cut easily.
2. Compressed air is must.
3. Foundation is required also safety measure must be taken.

### 8. FUTURE SCOPE

Since old age man is always trying to gain more and more luxurious. Man is always trying to develop more and more modified technique with increasing the aesthetic look and economic consideration. Hence there is always more and more scope. But being the Mechanical Engineers and having ability to think and plan. But due to some time constraints, and also due to lack of funds, we only have taught and put in the report the following future modifications.

- It can be made hydraulically power operated by installing the gear oil pump at the place air compressor and Pneumatic cylinder.
- It can be made rack and pinion operated or spring and lever operated. By replacing the pneumatic circuit by rack and pinion arrangement by square threaded screw and nut arrangement.
- The place where there is scarcity of the electricity the electric motor operate compressor is replaced by an IC Engine installed compressor.

Thus in there are so many modifications, which we can make to survive the huge global world or competition.

### 3. CONCLUSIONS

Now we know that Pneumatic Shearing Machine is very high cheap as compared to Hydraulic Shearing Machine.

The range cutting thickness can be increased by arranging a high pressure compressor and installing more hardened blades. This machine is advantageous to small sheet metal cutting industries as they cannot effort the expensive hydraulic shearing.

### ACKNOWLEDGEMENT

The authors can acknowledge any person/authorities in this section. This is not mandatory.

### REFERENCES

- [1] Prof. M. W. Andure, Suraj V Bhosale "Design and Fabrication of Pneumatic Sheet Metal Cutting Machine" ISSN: 2321-9653; IC Value: 45.98; SJ Impact Factor: 6.88; Volume 6 Issue 1, January 2018.
- [2] Suraj V Bhosale, Gajanan S Ghute, "Design and Fabrication of Pneumatic Sheet Metal Cutting-A review" e-ISSN: 2395-0056 p-ISSN: 2395-0072 Volume : 05; Issue: 01, 2018.
- [3] Asst.Prof. Raj Reddy, "Fabrication of Pneumatic Sheet Metal Cutter" ISSN NO. (print) : 0975-8364; ISSN NO. (online) : 2249-3255
- [4] Pneumatic System: Principle & Maintentance by S.R.Mujumadhar
- [5] Machine Design by R. S. Khurmi
- [6] Manufacturing Process by O. P. Khanna and Lal
- [7] Machine Tool Design Handbook

### BIOGRAPHIES



K. Uday Kiran,  
Assitant Professor,  
Department of Mechanical engg.



V. Naga Durga Ranjith,  
B. Tech, Student.



Md. Rizwan pasha,  
B. Tech, Student.



V. Vineela,  
B. Tech, Student.



Shaik. Ismail,  
B. Tech, Student.



R. Raj Kumar,  
B. Tech, Student.



Y. Thomas Nikhil,  
B. Tech, Student.