

IMPLEMENTATION OF LOW HARMONICS MULTILEVEL INVERTER USING SPWM

M.ABINAYA¹, C.V. CHAARU NISHA², K. ADITHYAN³, V. DHINAKARAN⁴, R. ARIVALAHAN⁵

^{1,2,3,4}Final year Student, Dept. of Electrical and Electronics Engineering, SRM Valliammai Engineering College, Kattankulathur, TamilNadu, India

⁵Associate Professor, Dept. of Electrical and Electronics Engineering, SRM Valliammai Engineering College, Kattankulathur, TamilNadu, India

ABSTRACT – DC to AC converters produce discrete wave forms and also produce harmonics, power losses and high frequency noise. Mostly neither the voltage nor the current has the necessary waveform. This will make the system uneconomical. Non-sinusoidal wave may lead to burning of equipment early. This project discusses the implementation of the scheme of an inverter system which converts the DC voltage collected from a Photovoltaic (PV) array into AC voltage. This output is a pure sine wave, with the DC to AC converters produce discrete wave forms and also produce harmonics, power losses and high frequency noise. Mostly neither the voltage and nor the current have the necessary waveform. This will make the system uneconomical. Non-sinusoidal wave may lead to burning of equipment early.

Keywords: Sinusoidal pulse width modulation (SPWM), Pure Sine Wave; Single phase inverter; Photo Voltaic (PV).

1. INTRODUCTION

Solar energy is one of the potential sources, which is preferred over others due to availability, simplicity, lower maintenance and reliable operation. Photovoltaic arrays can provide an excellent, cost saving solution for users requiring large amounts of power. the main motto is to regulate the voltage for non- linear load conditions.

A DC/AC power inverter is needed to convert the DC voltage gathered by photovoltaic cells into ac voltage. The sine wave inverters give a pure sine wave output. They operate in near perfect efficiency, maximizing the output. Use of inefficient square wave inverters put additional strain on our already crippled power sector. So, while using a renewable energy source, the aim should be to maximize the power consumption.

1.1 WORKING OF THE PROJECT

The basic concept of an inverter is to convert the direct current to an alternating current. The multi-level inverter consists of many square pulses in single half cycle. By creating the pulse width modulation in multi-level inverter, the harmonics and ripple factor can be reduced. A sine wave is a continuous wave with the smooth repetitive oscillations.

1.2 MULTILEVEL PWM STRATEGIES

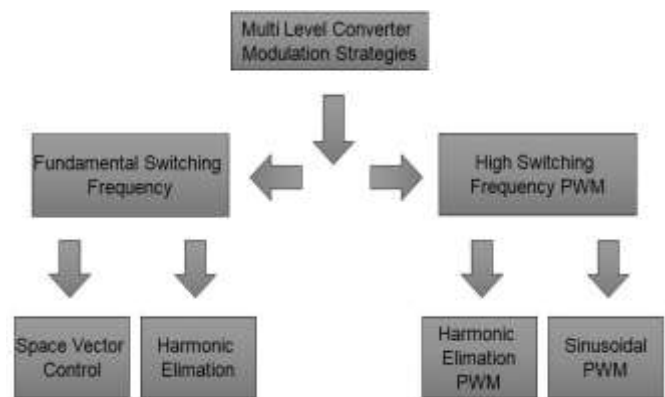

2. LITERATURE SURVEY

2.1 Existing System

The existing system has the structure of a multilevel voltage source thyristor inverter. This concept is used to decrease the harmonic distortion in the output waveform without affecting the power output. A simple PWM control of the voltage is enough to practically remove all harmonics.

2.2 Proposed System

The aim of this work is design and implementation of a multilevel inverter system. This work is expected to help to understand the basics need for cost effective inverter system for future generation. PWM has advantage of the low ripple factor and maximizes the system efficiency.

3. COMPONENTS

- ❖ Power IGBT
- ❖ Control Circuit
- ❖ Filter Circuit

3.1 BLOCK DIAGRAM

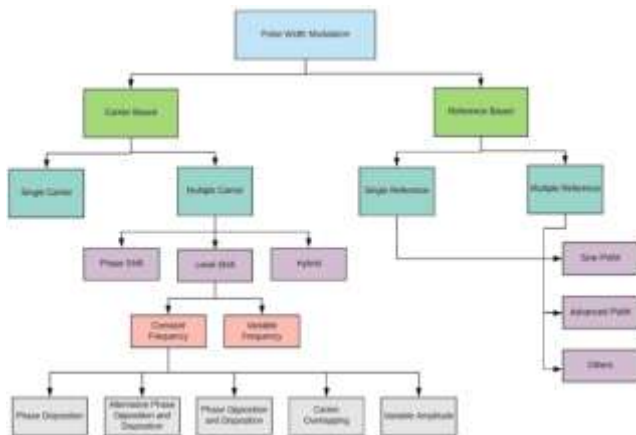

4. HARDWARE USED

- ❑ The elements of this work includes:
 - ❖ DC Supply (Input Source)
 - ❖ Power IGBT
 - ❖ Driver Circuit
 - ❖ Control Circuit
 - ❖ Filter Circuit
- ❑ INPUT VOLTAGE 220V (Direct Current)
- ❑ OUTPUT
 - ❖ Voltage - 230V Single Phase 50Hz (Alternative Current)
 - ❖ Current - 16 ampere
 - ❖ Power - 3800 watts

5. OPERATION

- 1) To power the motor, we use a Li-Po battery. The capacity-to-mass coefficient of such cells is really high. Also, they are able to output a high current value which is so required for brushless motors.
- 2) Arduino pro micro is the brain of the flight board, it controls the overall operation of the bat, the weight of this component is very less compared to other Arduinos.
- 3) To steer the bat, we need two servos that position the tail. One servo for attitude control (Pitch). Second for turns (Roll). These are powerful and fast servos.
- 4) To create a connection between the remote control and the bat, we need a receiver and a transmitter. Both of these functions can be performed using RF transmitter and receiver.
- 5) ESP32-CAM is a dual-mode WIFI+ Bluetooth development board which uses on-board PCB antennas and ESP32 chip-based cores.

As a minimal device it should work independently.

6. SIMULATION

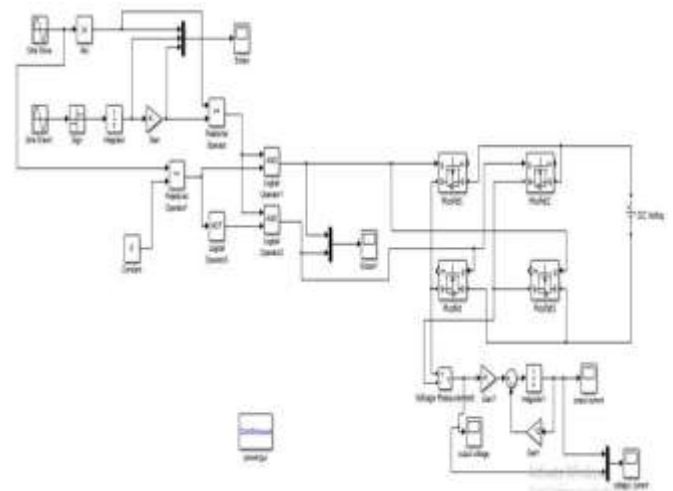
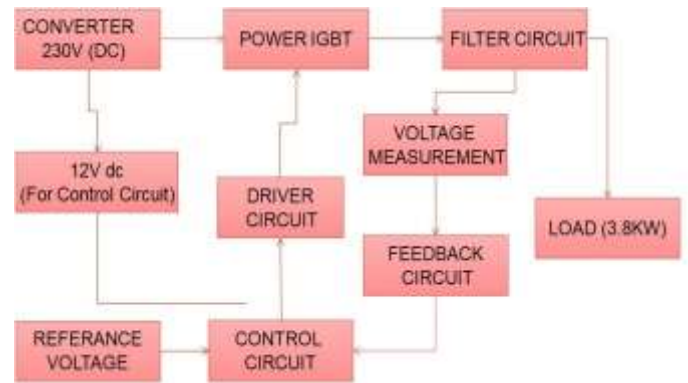

6.1 SIMULATION OUTPUT

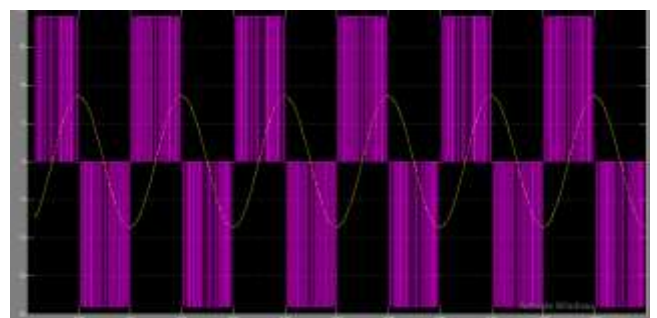
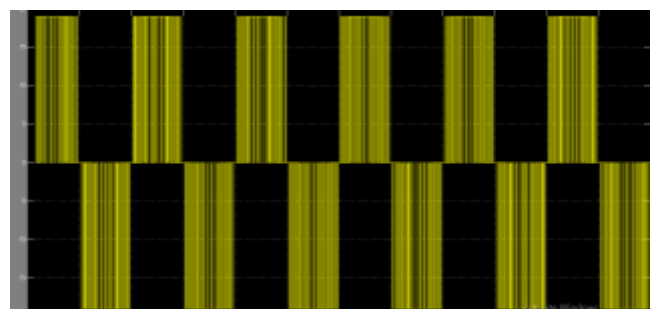

Many Components are used In Multi-Level Inverter. It will make the circuit more complex and cost of the Inverter is high. Due to Large Number of Sources, Applications Are Limited

7. CONCLUSION

The implementation of this project is to Invert Low Level DC Source to High Level AC Voltage Efficiently and to Perform the Harmonic Elimination and Also to Reduce the Total Harmonic Distortion. This is also used to develop a Cost-Effective Inverter System to Provide Pure Sine Ac at Maximum Efficiency.

8. REFERENCES

- [1] Salman Salman, Xinal, Zhouyang WU, "Design of A P-&-O Algorithm Based MPPT Charge Controller for A Stand-alone 200W PV System, "International Journal of Innovation and Scientific Research, Volume 40, Issue 1, Dec. 2018
Volume 39, Issue 2, Nov. 2018
- [2] Rayyan Azam Khan, Liaquat Ali Khan, Farzan Majeed Noori, Zareena Kausar, And Aaqib Majeed, "Design and Simulation of a Sine Wave Inverter with PID Control for Nonlinear Load Applications," International Journal of Innovation and Scientific Research, Vol. 26, No. 2, Pp. 672-683, September 2016.
- [3] Vamsikrishna Patchava, Hari Babu Kandala, P Ravi Babu, ' A Digital Home Automation Strategy with Rasp-berry Pi Using Iot, ' International Mobile Sensors and Systems Meeting, 2015.
- [4] B. Charitha, "An IOT Based Smart Inverter", IEEE International Conference on Recent Trends in Electronic Information Communication Technology, 2017
- [5] 600-Watt Pure Sine Wave Inverter donrowe.Com December 14, 2006

9. BIOGRAPHIES

MS. M. ABINAYA is a final year student of Department of Electrical and Electronics Engineering, SRM Valliammai Engineering College, Kattankulathur.

Ms. C.V. CHAARU NISHA is a final year student of Department of Electrical and Electronics Engineering. SRM Valliammai Engineering College, Kattankulathur.

Mr. K. ADITHYAN is a final year student of Department of Electrical and Electronics Engineering. SRM Valliammai Engineering College, Kattankulathur.

Mr. V. DHINAKARAN is a final year student of Department of Electrical and Electronics Engineering. SRM Valliammai Engineering College, Kattankulathur.

Dr. R. ARIVALAHAN is an Associate professor of Department of Electrical and Electronics Engineering. SRM Valliammai Engineering College, Kattankulathur.