

Design, And Manufacturing of Automatic Sheet Metal Bending Machine

Amar Khot¹, Bhushan Satpute², Amit Jambhale³, Arjun Jadhav⁴, R.K.Shirsat⁵

⁵Professor, Dept. of mechanical Engineering, Dr.D.Y Patil. Pratisthan College of Engineering Salokhenagar, Kolhapur, Maharashtra, India.

¹²³⁴Students of D.Y.Patil.Pratisthans College of Engineering Salokhenagar, Kolhapur-416001

ABSTRACT – Bending machine is a common tool in machine shop that is use to bend a piece of metal. It is widely used in various industrial operation such as bending a tube to make coil or sheet metal to make certain shape such as V- shape there are many kind of bending machines that can be found in small scale industry which are not feasible for bending smaller sheet metal, here “Design and development of sheet metal bending machine”. Is taken as a project.

By conducting literature review, it was identified that there is no machine available to bend that small job and also identified the cost of machine as too height. To understand the user and has environment, data collection project was carried of with small scale industries. Some of the problems were revealed such as to bending easily, attachment of multiple fixture, metal strip guide and also reducing the cost.

1. INTRODUCTION

Currently sheet bending is carried out manually on bench vice by using hammers. Hydraulic press will reduce the human efforts involved and also give a higher dimensional accuracy of job.

In bending operation the bend has been made with the help of punch which exerts large force on the work clamped on the die. The bending machine is designed in such a way that, it works automatically. The machine is designed by observing the factors to improve the efficiency and to reduce the cycle time by producing quality output. Automation of machine is achieved with the help of pneumatic system. This involves the design of an efficient system which reduces the human effort and help to increase production output. It also includes pneumatic system, pneumatic component and shearing die and bending die.

The hydraulic cylinder have to forces which are the piston force in the forward direction and the cylinder force in the back direction. Those forces are equal in magnitude, but opposite in direction and collinear to each other. The piston force is used for the purpose of bending while the cylinder force is exerted on the cylinder support that have no function simply lost without any function but it cause failure on cylinder support.

In this machine developed a simple mechanism that handle and maximize the hydraulic cylinder and piston force for the purpose of bending as a result the machine become light in weight and low in cost.

2. DESIGN AND DEVELOP

2.1 Calculations for Hydraulic press

Bending Force: -

The force required to bend the sheet in to required dimensions is called as bending force.

- Bending force

$$F_b = \frac{c \times b \times t^2 \times \sigma_y}{w}$$

Where,

c: die opening factor (1.33 for 'v' bending)

b: width of sheet (100 mm)

t: thickness of sheet (2 mm)

σ_y : yield strength of mild steel (276 Mpa or N/mm)

w: width of die opening (8*t for 'v' bending)

Therefore,

$$F_b = \frac{1.33 \times 100 \times 2^2 \times 276}{8 \times 2}$$

- $F_b = 9177 \text{ N}$

- $F_b = \frac{9177}{9.8} = 936.5 \text{ kg} \approx 1 \text{ ton}$

- Maximum thickness of sheet that can be bent by 3000kg load = 6.4 mm

2.2 Deflection of beam-

The design of such beams can be complex but is essentially intended to ensure that the beam can safely carry the load it is intended to support. The beam in this hydraulic press is the important factor. The sheet bending machine has two beams. The upper beam has a punch welded on it while the lower beam has the die. The minimum width of die opening for 'V-Bending' is given by 8 x thickness of sheet= 16mm. Therefore the 16

mm groove was made on the beam carrying die (lower beam) with milling tool of tool angle 90° in our workshop.

$$\square \text{ Deflection of Beam} = \frac{1}{48} \times \frac{WL^3}{EI}$$

Where,

W = total load,

$$I = \text{Moment of inertia} = \frac{bd^3}{12} \\ = \frac{300 \times 40^3}{12} = 1.6 \times 10^6 \text{ mm}^4$$

E = Youngs Modulus (200 GPa or 200 x 10⁹ N/mm)

L = length of beam (300 mm)

The Allowable deflection of beam is given by

$$\begin{aligned} \text{Allowable deflection} &= (1/325) \times \text{length of beam,} \\ &= (1/325) \times 300 \\ &= 0.923 \text{ mm} \end{aligned}$$

Therefore, I have to choose the appropriate beam dimensions such that the deflection of selected beam would not exceed 0.923 mm. Also, the fact should be kept in mind that the lower beam (the beam with die) is a moving beam, therefore a proper sliding surface is to be provided in order to make the movement of beam with die properly in the C-columns. Thus, a beam of 300mm length, 40 mm width and 40 mm depth are selected.

For beam of 300x40x40, deflection = 51.67 x 10⁻³ mm. Hence, the deflection for selected beam is almost half of the allowable deflection. Therefore, the design of beam is safe and accepted.

2.3 Specification of Motor:

1. Phase -3
2. Amb-45°
3. Duty-S1
4. Efficiency-66%
5. Frame-71
6. Hz-50 ±5%
7. Velocity-415 ±10%
8. Kw/HP-0.37/0.50
9. A-1.05
10. Rpm-1440
11. Pf-0.74
12. Ratio-7
13. Fr-71
14. HP-0.5

3. CONSTRUCTION

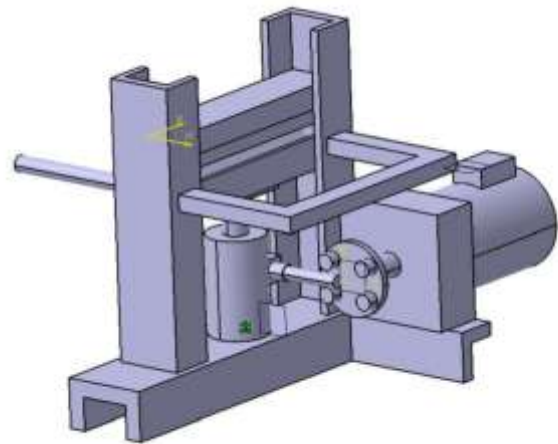

Fig 1- 3D Working Model

4. FUTURE SCOPE

- Automation for pumping action using electronic circuit and motor.
- The above measures would increase the productivity of press as time and efforts involved would become less.
- By increasing capacity of hydraulic jack we can bend metal sheet more than 6 mm.

5. CONCLUSION

In this machine the whole operation is controlled by hydraulic cylinder then the machine become simple in feature and operation as well as low in cost and light in weight machine. Hydraulic cylinder backward force is handled for the purpose of bending. The piston forward and cylinder backward force are multiplied by the mechanical advantage of right angle lever.

6. REFERENCES

1. P. S. Thakare, P. G. Mehar, Dr. A. V. Vanalkar and Dr. C. C. Handa, "Productivity Analysis of Manually Operated and Power Operated Sheet Bending Machine: A Comparative Study", International Journal of Engineering Research and Applications (IJERA), ISSN: 2248-9622, Vol. 2, Issue 2, Mar-Apr 2012, PP.111-114.
2. V. Senthil Raja, R. Maguteeswaran, C. Karthik, S. Rajarajan and D. ShanmugaVadivel, "A New Model in Design and Manufacturing of Mobile Hydraulic Pipe Bending Machine in Industry", International Journal of Engineering Research &

Technology (IJERT), ISSN: 2278-0181, Vol. 3
Issue 1, January – 2014 PP 2706-2713.

3. H. A. Hussain, M. Sohail Pervez, Md. NaushadAlam and Atul. P. Ganorkar, "Design and Development of Bicycle Integrated Pipe Bending Machine", IOSR Journal of Mechanical and Civil Engineering (IOSRJMCE), e-ISSN: 2278-1684, p-ISSN: 2320-334X, 2014, PP 24-28.
4. Gum/AR d E. EABERG' Patented Apr. 6, 1954
UNITED STATES PATENT OFFICE PLATE
BENDING MACHINE Application February 19,
1953, Serial No. 337,808