

LANDMINE DETECTION AND MARKING ROBOT

Sayali Ranaware¹, Rushabh Pahade², Diksha Sable³, Prof. Shruti Danve (Guide)⁴

^{1,2,3,4,5}Dept. of Electronics and Telecommunication Engineering, MIT College Pune, Maharashtra, India

Abstract - The landmine is very serious problem as it creates lots of catastrophic situations. Primarily landmine is big problem for soldiers because enemy countries use this technique to injure the soldiers or destroy the military vehicles. Landmines are not just limited to destroying military troops but they can also be used to take the lives of civilians. Hence because of all these issues the government needs to take proper actions which can help in controlling this problem. The technologies which are developed until now are not reliable and also dangerous for humans. This includes biological technique where dogs are used to search landmine. Other one is stick which has landmine detector on it. The person needs to take the stick near the landmine prone area and search for landmine but if that stick fails to detect landmine it can take the life of the person. So, the basic concern of our project is to develop a landmine detection robot which will be able to detect a landmine buried inside land and mark the location and send this location to the central station so the person can come to know about landmine. The whole system is operated wirelessly without any human involvement on landmine field.

1.1 System Architecture-

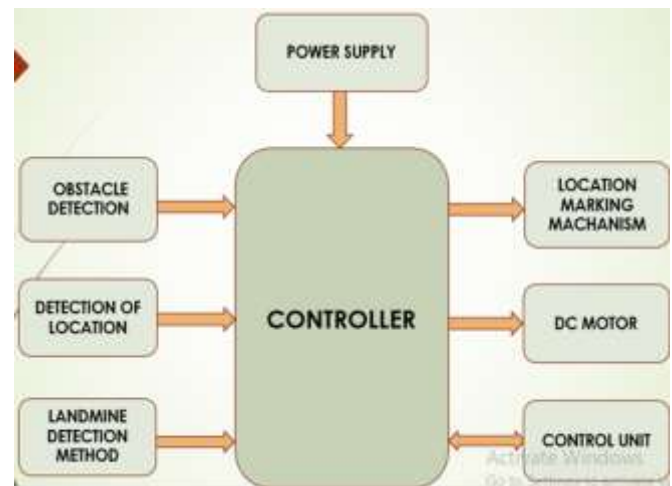

Fig -1: Block Diagram

1.2 Robot design

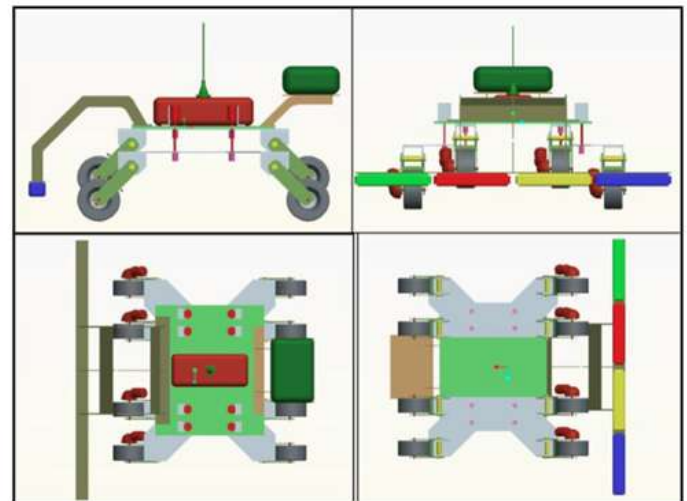

Fig-2: Robot Design

1. INTRODUCTION

The main problem faced is to find out the landmine because they are buried. So, detecting and destroying them is not an easy task and it needs lot of accuracy and precaution. Small mistake can lead to serious damage to the human life. So, for solving this problem we have come with the solution. One can detect and destroy landmine without going near to the landmine prone area. For this robot is used. So firstly, Power is supplied to turn on the system. The Bluetooth terminal application is used to navigate the robot. DC motor is used for the movement of wheels of the robot. Ultrasonic sensor is used to detect the obstacles in the way so we can move the robot accordingly. Metal detector is attached at a distance of 5 meters from the robot by using an arm. The metal detector will scan for landmines in close proximity. When the landmine is detected the robot will stop automatically. Buzzer will be activated and the sprinkler motor will spread colored water on that portion. The location of the landmine is transmitted to the user using GPS. After this we maneuver the robot to avoid it from stepping on the landmine. If the landmine is not found then the metal detector keeps scanning until the next landmine is found.

2. COMPONENT

OBSTACLE DETECTION-

Ultrasonic Sensor (also known as an ultrasonic transducer) is based on a transmitter and a receiver. It is mainly used to determine the distance from the any obstacle. This distance can be used to determine any big stone/tree present in front of the robot, so it can be moved safely without any damage. The amount of time the sensor takes to send and receive waves will determine how far the object is present from the sensor. It mainly depends on the sound

waves working on “non-contact” technology. The required distance of the target object is measured without any damage, giving you accurate and precise details.

DETECTION METHODOOD-

Non-contact metal detector module is used for the prototype. This is a module specifically designed to detect metal. The module operates by inducing currents in metal objects and responding when it occurs. For the past decade, landmines are made in metal casings. Therefore, the detection of landmine by using metal detectors is a reliable and workable method. Moreover, the metal detectors can give out false signals upon sensing every presence of metal piece instead of only when detecting the real mine. Due to the above reasons, this method is used for the prototype. In actual implantation Acoustic-Seismic method is the best. This, though, is a very costly method for mine detection. Due to budget constraints, the idea of employing and experimenting with the Acoustic Laser Sensor is neglected in this project. The same applies for other better options since the equipment is expensive and requires military clearance in order to purchase one. Hence, even though metal detectors may seem inferior in performance, they are the most suitable to be used in this small-scale project.

LOCATION MARKING MECHANISM

This is 550 Diaphragm Pump 12V Water Pump for Water Spray Fish Tank Reflux Pump. When motor gets signal it will spray colored water. At the time of the scanning of the entire landmine field, if there is landmine present then this will be detected by metal detector and after that the location will be marked by using the sprinkler motor.

ROBOT MOVMENT

DC Motor 300RPM 12Volts geared motors are generally a simple DC motor. They can be used in robots and variety of robotic applications. These motors have a 3 mm threaded drill hole in the middle of the shaft thus making it simple to connect it to the wheels or any other mechanical assembly. Dc motor is used for wheel of the robot along with its driver circuitry, This wheel is controlled by Bluetooth. By giving proper commands it can be moved in any direction. Hence robot can easily operate from specific distance.

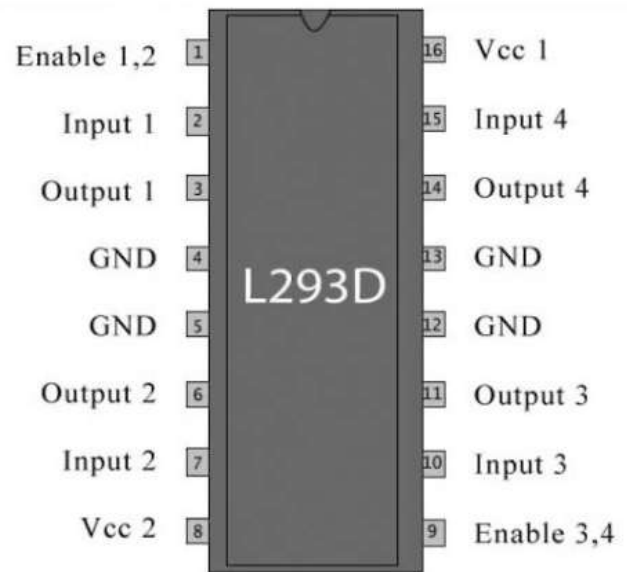

Fig-3: DC Motor Driver IC

DETECTION OF LOCATION

NEO-6MV2 GPS Module is one of most popular GPS modules in the market and is also cheap to buy. The location data provided by it is accurate enough to satisfy most applications. This module is placed along with metal detector for getting accurate data of the location. When landmine is detected then that specific location is known.

CONTROL MECHANISM

All units of this project is controlled by using HC-05 Bluetooth module. Bluetooth allows us to operate Robot from specific distance. For the prototype we are using Bluetooth terminal application. By using this application it is possible to send and receive data easily. This application is used to send the command to the robot wheel so that the robot can be moved in left/right/backward/forward directions. Also, when landmine is detected that location is available on this application.

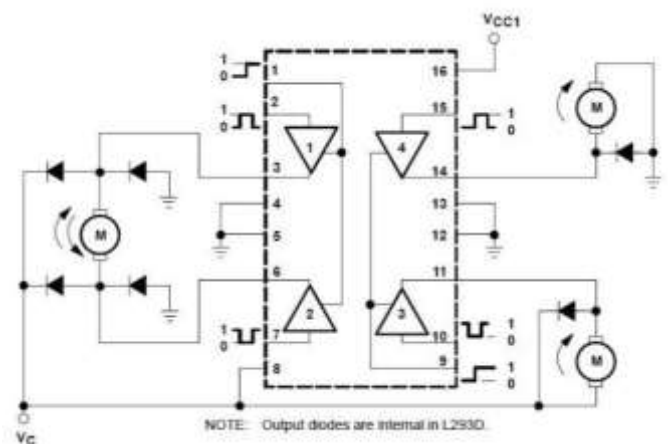

Fig-4: Internal Circuitry of Driver

Four motors can be operated on single L293D driver IC. The arrangement made in such a way that two motors are connected to left side and another two motors on right side. In figure-4 pin 1 and 9 are enable pins. To activate left side then +5V supply is given to pin 1 and to activate right side +5V supply is given to pin 9, and pin No 16 required to operate internal circuitry of given IC.

When we apply logic 1 to the pin No 2 and logic 0 to the pin No 7 then diode D1 is in forward bias and diode D2 in reverse bias condition.

When logic 0 present on pin No 7 then diode D3 is in reverse bias and diode D4 is in forward biased, therefore motor voltage is applied on pin No 8. In this case one end of motor has high potential and other end of motor has low potential so it turns.

At the time when same logic is present on both the inputs then all motor will remain off because both terminals have same potential.

SYSTEM FLOW-

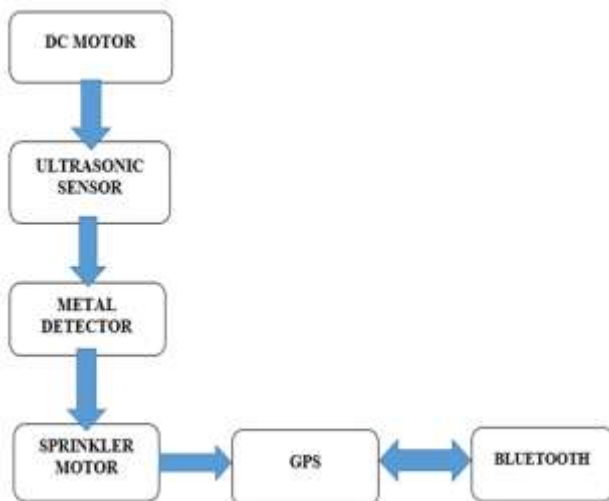

Fig-5: System Flow

3. CONCLUSIONS

Landmine contamination remains a major problem worldwide. Thousands of injuries and death result from landmine, despite the fact that they have been banned in warfare for 20 years. Landmines are not a problem that will disappear anytime soon, and current methods of clearing minefields are too expensive, or unacceptably risky. Mine clearance is exhausting, dangerous, repetitive work so they are poorly suited for humans, but perfect for a robotic solution. The purpose of this project is to find and mark the landmine. Our robot will continuously scan the given minefield and if the landmine is detected then it will report to the station and location is recorded. This project shows

that a robotic solution to the problem of landmine detection and removal is a practical alternative to current solutions.

ACKNOWLEDGEMENT

With all respect and gratitude, we would like to thank our project guide and project in charge Prof. Shruti Danve, Head of department Prof. V.V. Shete, Principal Dr. Prof. Hiwale for their guidance. This project wouldn't have been conceivable without their help. We take this opportunity to express our sincere thanks to other faculty members for their valuable suggestions and encouragement during the course of the project. We feel it was their experience and inspiration that kept us improving and grasping for perfection. Finally, we thank all teachers for their endless help for us to accomplish our task with great efficiency.

REFERENCES

- [1] Aoyama, H., Ishikawa, K., Seki, J., Okamura, M., & Ishimura, S, "Development of mine detection robot system", Fuji Heavy Industries Co. Ltd, pp. 229-236, 2006.
- [2] Arnott, W. P., & Sabatier, J. M., "Doppler vibrometer measurements of acoustic to seismic coupling", Applied Acoustics, Vol. No 30, pp. 279-291, 1990.
- [3] Cassinis, R., "Landmines detection methods using swarms of simple robots", Brescia, Italy, 2000.
- [4] Chann N., "Mine detection and marking robot", National University of Singapore, 2000.
- [5] Mcaslan, A. R., & Bryden, A. C., "Humanitarian demining in South Eastern Europe- An analysis of capability shortfalls and user needs", The Geneva International Center for Humanitarian Demining, 2000.
- [6] Robledo, L., Carrasco, M., & Mery, D., "A survey of landmine detection technology. International Journal of Remote Sensing", pp. 2399-2410, 2009.
- [7] Sutin, A., Johnson, P., Tancate, J., & Savazyan, A., "Time reversal acousto-seismic method for land mine detection", Stevens Institute of Technology, pp. 706-716, 2012.
- [8] Making landmine detection and removal practical <http://www.llnl.gov/str/Azevedo.html>
- [9] Use of Unmanned Aerial Vehicles (UAVs) for Land Mine Detection <http://www.mondialogo.org/129.html>