

Design and Fabrication of Smart Braking System

S.V.Borkar¹, Aniket A. Kamdi², Himanshu V. Kale³, Aman G. Dhanvijay⁴, Akash A. Wanjari⁵,
Akash D. Goswami⁶

¹Asst. Professor, Dept. of Mechanical Engineering, PBCOE, Nagpur, Maharashtra, INDIA

^{2,3,4,5,6}Student 8th sem, Mechanical Department, PBCOE, Nagpur, Maharashtra, INDIA

Abstract - The purpose of the paper is to Design Smart hand braking system is to reduce the chances of accidents on the road. The paper gives you the detail about the parts and working of the smart braking system for long time by reducing collision of vehicles, which can adversely affect the safety and its assurance of quality. By accomplishing the aim of the project everyone can drive safely also which can be easily acceptable in the market. If the parking brake content is present manually in the braking system then it is not suitable for safe drive and further process. If the driver have lot of hectic driving schedule then it can increase the chances of accidents because of his tiredness. This paper gives the solution for the limitation of manually operating hand braking system or manually operated parking brake system which is time consuming process or operation. The parking brake or hand brake is a conventional method to apply the parking brake, as it takes much time, more space and more efforts. At the very start, When the vehicle is started or ignition is ON, This sends a signal to the control unit such that it reverse the high torque motor and parking brake will get remove. High torque motor releases automatically When the engine ignition is off, the motor works in the reverse direction to lock the hand brake. whenever driver will get distracted or sleep during the driving the sensor senses the distance between two vehicle and give one buzzer sound for the driver when the vehicle is too close And Similarly vehicle will get slow down.

Key Words:- High Torque Motor, E.C.U(Microcontroller), Ignition, Battery, Brake Cable, Sensor.

1. INTRODUCTION

In road vehicles, the emergency and place on referred to as a emergency or emergency could even be a mechanism accustomed keep the vehicle firmly static once set. historically, it had been place on accustomed facilitate perform associate emergency stop have to be compelled to the foremost hydraulic brakes fail. Parking brakes generally contains a cable connected to two wheel brakes, that's then connected to a pull mechanism. In most vehicles, the emergency operates alone on the rear wheels, that have reduced traction whereas braking. The mechanism is also a manual lever, a straight pull handle located on the aim of the steering column or a foot-operated pedal located with the alternative pedals.

As safety rules became exacting inside the 19 Eighties, trendy and stylish and classy brake systems became further reliable fashionable brakes not cause emergencies in ancient

contexts; a brake red light-weight appears on the dashboard if there was a problem. it isn't as necessary for a driver to use this brake for emergencies, if it were to be used, the emergency lever have to be compelled to be slowly engaged to help shrink speed.

In manual and transmission vehicles, the emergency can also be used for numerous driving things that require the vehicle to be momentarily stopped. as associate example, the brake unit aiming to be engaged once moving off associate uphill slope, as this allows the thrust to hold the accelerator and clutch pedals steady whereas not the vehicle rolling backwards. various common things is once the vehicle is stopped at a stoplight, a path, or simply waiting to purpose before oncoming traffic. The emergency would certify the automotive is secure, have to be compelled to another vehicle get physical contact from behind, inflicting the automotive to jolt forward. it isn't urged to use the emergency once the vehicle is in-motion, unless there is a agent with the foremost brakes, as this might lock the rear wheels and cause a skid. this will be referred to as a handbrake flip, that's usually performed in street athletics and cross-country rally athletics to initiate rear wheel drift

In vehicles with rear disc brakes, the emergency brake either actuates the disc calipers or a tiny low hydraulic brakes housed within the hub assembly Hudson cars used degree uncommon hybrid hydraulic-mechanical dual-brake system that operated the rear brakes through the otherwise typical mechanical emergency brake system once a failure of the mechanism allowed the pedal to travel on the so much facet its ancient limit. A number of production vehicles, light-weight and medium duty trucks, and motor homes are created with a separate hydraulic brakes on the driveline; mentioned as a transmission brake.

This features a and of being totally freelance of other braking systems. typically this can be often effective once there unit of measurement multiple driving axles, all driven wheels unit of measurement braked directly. A line lock is also a brief emergency brake that produces use of the vehicles customary hydraulic brakes. they are usually used for off road conditions or once stopping on steep grades is required. By trappings hydraulic pressure among the brake lines, all four wheels is barred.

2. LITERATURE SURVEY

- ❖ **DESIGN & ANALYSIS OF PARKING BRAKE SYSTEM - Amit B. Maske, S.B Tuljapure, P.K Satav:-**This paper describe the new parking brake system also referred to as brake by-wire, replace conventional parking brake hand lever with a electronic switch. By the replacement of conventional linkages with electric motor-driven units. The braking force is generated by high power DC motors and gear reduction by which parking brake is applied.
- ❖ **AUTOMOTIVE BRAKING SYSTEM FOR PASSENGER VEHICLE TO ENHANCE SAFETY - Dineshkumar C, Subramanian M:-** In this research paper we have studied The IR sensor is placed in front bumper The signal from the IR sensor which is connected to the stepper motor through control unit which make the braking system to control at this situation. The speed sensor senses the speed of the vehicle and stepper motor is activated depends on the speed of the vehicle. The braking is activated by programmed in the control unit.
- ❖ **REVIEW PAPER ON IGNITION SWITCH OPERATED PARKING BRAKE SYSTEM - Mulik Vishal Shamrao, Chavan Akshay Shivaji, Chavan Akshay kumar Nanaso, Bagade Ravindra Jalindar:-** This paper describes the study of design of Hand brake is one of the most important components in vehicles. some of the case hand brake is operated manually. in our project we are developing the Ignition Switch Operated Automatic Parking Brake System for safety purpose.
- ❖ **CIRCUIT OPERATED parking brake - Anup Sonawane, Dinesh Panchal, Karan Tekwani, Omkar Garud, Ashutosh Joglekar:-**This paper is delineated In circuit operated parking brake the brake are engaged and disengaged with the assistance of electrical motor and small controller. the electrical motor are operated by the command given by the microcontroller. Microcontroller is programmed such as electric switch is turned Off then the microcontroller can rotate in opposed dextrorotary direction inflicting the parking brake to have interaction and the other way around.
- ❖ **A REVIEW ON VEHICLE COLLISION shunning SYSTEM - Mir Insha Mushtaq, Manish Kansal:-**during this analysis paper we've studied the "Vehicle Collision shunning System" in Associate in Nursing automobile system could be a safety system that's designed to cut back the possibilities of collision. to trace the objects and to require any action to avoid risk of collision "Vehicle collision shunning System" is employed. Once the detection

is completed concerning the collision these systems give a warning to the motive force either by braking or steering.

3. DESIGN OF PROJECT

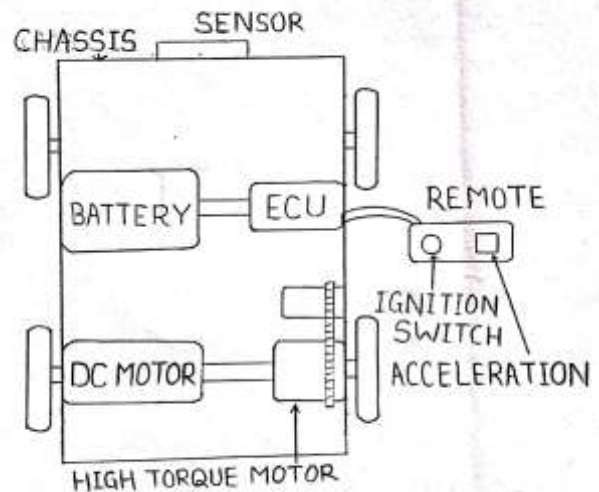

4. COMPONENTS

- ❖ **HIGH TORQUE MOTOR:** A DC motor is any of a class of rotary electrical motor that converts direct current electrical energy into mechanical energy. The sequence of turning a particular coil on or off dictates what direction the effective electromagnetic fields are pointed. By turning on and off coils in sequence a rotating magnetic field can be created. These rotating magnetic fields interact with the magnetic fields of the magnets in the stationary part of the motor to create a torque on the armature which causes it to rotate. In some DC motor designs the stator fields use electromagnets to create their magnetic fields which allow greater control over the motor. DC motors were the first form of motor widely used, as they could be powered from existing direct-current lighting power distribution systems. Larger DC motors are currently used in propulsion of electric vehicles, elevator and hoists, and in drives for steel rolling mills.
- ❖ **SONAR SENSOR:** This sensors work by emitting sound waves at a frequency too high for humans to hear. They then wait for the sound to be reflected back, calculating distance based on the time required. This is similar to how radar measures the time it takes a radio wave to return after hitting an object.
- ❖ **MICROCONTROLLER(E.C.U):** A microcontroller is a small computer on a single metal-oxide-semiconductor (MOS) integrated circuit chip. A microcontroller contains one or more CPUs along with memory and programmable input/output peripherals.

Program memory in the form of ferroelectric RAM, NOR flash or OTP ROM is also often included on chip, as well as a small amount of RAM. Microcontrollers are designed for embedded applications, in contrast to the microprocessors used in personal computers or other general purpose applications consisting of various discrete chips

❖ **BRAKE CABLE:** Fan and heating element used to provide hot air to the grain. high speed RPM fan is used to provide the air in the machine & heating element is used to provide warm air into the machine.

❖ **BATTERY:** The power required to drive the dc motors and to assembly of the desired project.

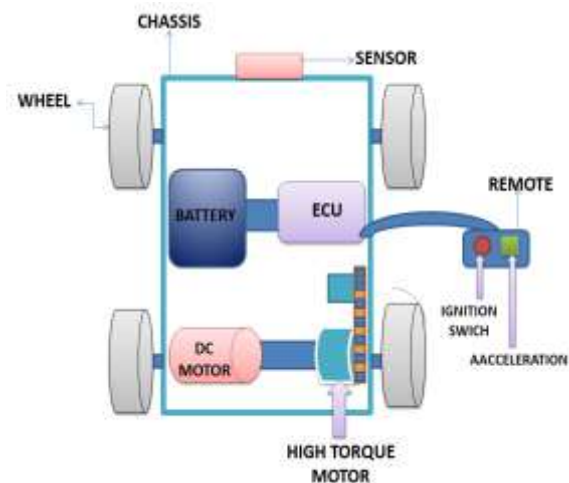

5. WORKING METHODOLOGY

It is a system which is designed for automobiles using hand brake. In cars, the parking brake, also called hand brake is a latching brake usually used to keep the vehicle stationary. Hand brake is used to prevent a vehicle from rolling down when parked in an inclined road or when the operator needs to start from a slant road.

Most of the driver forget to apply hand brake when they leaves their car. Due to this accidents happen. Sometimes driver does not apply hand break and they leave their car in gear engage position, due to this there is a play In gears and load is apply on it in stationary condition.

There is no automatic hand brake system available for middle range car segment. High torque motor releases automatically whenever the key is in ignition state. When the engine ignition is off, the motor works in the reverse direction to lock the hand brake.

When the vehicle is started or ignition is ON, This sends a signal to the control unit such that it reverse the high torque motor and parking brake will get remove. For the safety reason we include intelligent braking system, whenever driver will get distracted or sleep during the driving the sensor senses the distance between two vehicle and give one buzzer sound for the driver when the vehicle is too close And Similarly vehicle will get slow down.

6. APPLICATION

The main applications are that it can be used in Automobile industry, smart brake to reduce chances of accident also used in automobile industry for drying safety concern. Smart parking brake system is quick responding system. The smart parking brake, it can be easily acceptable in market & it gives good value in market. The government norms has facing trouble in bulk quantity it is very hard task to reduce the number of quantity of accidents & that to safely so the project will ultimately help the government as well as owner of the vehicle so that they may not face the loss especially during monsoon season. Due to unexpected rainfall, rainstorms the driver is unable to drive properly and due to this the vehicle will get crashed or collide and we prevent vehicle and driver from accident by using our smart hand braking system.

7. ADVANTAGES

- [1] The smart hand brake system design is economical for Automobile Industry and vehicle owner.
- [2] The vehicle can be get protected from accidents due to collision avoidance system present in the vehicle.
- [3] The Smart Parking brake system is not dependent on weather condition so that it can work in any season.
- [4] For the process of smart parking brake system of vehicle less effort is required.
- [5] Better control over a braking and collision content over a accident.
- [6] Operating procedure of the system is very simple.

8. CONCLUSION

From this paper we have conclude that it is very hard task to prevent collision from that much of quantity & that to safely so the project will ultimately help the government as well as passenger so that they may not face the loss. The project is prevent the vehicle from accidents by adding

smart parking brake system to vehicle within less time, less space, & cheap cost. The whole system is quick responding and beneficial for the both driver and passenger.

9. REFERENCES

- [1] Amit B. Maske¹, S.B Tuljapure², P.K Satav³
- [2] Dineshkumar C1 Subramanian M2
- [3] Mulik Vishal Shamrao¹, Chavan Akshay Shivaji², Chavan Akshaykumar Nanaso³, Bagade Ravindra Jalindar⁴
- [4] 1 Anup Sonawane , 2 Dinesh Panchal , 3 Karan Tekwani , 4 Omkar Garud , 5 Ashutosh Joglekar
- [5] Mir Insha Mushtaq¹, Manish Kansal²

BIOGRAPHIES



S.V.BORKAR is working as an Assistant Professor in M.E Department in Priyadarshini Bhagwati College of Engineering under Rashtrosant Tukdoji Maharaj Nagpur University, having 13 years of Teaching experience. Her research areas include Fluid Mechanics, Hydraulic machines, Automobile engineering, Refrigeration and Air conditioning, Engineering Heat Transfer and Energy conversion. Graduated in Bachelors of Mechanical Engineering, and done M. tech in Heat Power Engineering. also she pursuing PHD in Mechanical Engineering. She has guided more than 50 students for UG Projects. she has published more than 15 Research papers in National and International Journal and Conferences. And also she is a professional body member of Indian Society For Technical Education.



ANIKET A. KAMDI are the students of 8th semester, Mechanical engineering of priyadarshini bhagwati college of engineering and presently working on the project of Design and Fabrication of Smart Hand Braking System.



HIMANSHU V. KALE are the students of 8th semester, Mechanical engineering of priyadarshini bhagwati college of engineering and presently working on the project of Design and Fabrication of Smart Hand Braking System.



AMAN G. DHANVIJAY are the students of 8th semester, Mechanical engineering of priyadarshini bhagwati college of engineering and presently working on the project of Design and Fabrication of Smart Hand Braking System.



AKASH A. WANJARI are the students of 8th semester , Mechanical engineering of priyadarshini bhagwati college of engineering and presently working on the project of Design and Fabrication of Smart Hand Braking System



AKASH D. GOSWAMI are the students of 8th semester , Mechanical engineering of priyadarshini bhagwati college of engineering and presently working on the project of Design and Fabrication of Smart Hand Braking System