

# LUBRICATING OIL CONDITION MONITORING SYSTEM IN DASHBOARD

DR.K. Senthilkumar<sup>1</sup>, S.S. Aakash<sup>2</sup>, R. Raghul kishan<sup>3</sup>, N.Nithin<sup>4</sup>, T.Vijay<sup>5</sup>

<sup>1</sup>Professor of Head, Automobile Engineering, SNS College of technology, Coimbatore,  
<sup>2,3,4,5</sup>students, Automobile Engineering, SNS College of technology, Coimbatore.

\*\*\*

**Abstract** - Automobile industry is a growing industry which necessitates the importance of lubrication. Lubrication is mainly done for the proper functioning of machine and frictionless working of components of various parts such as engines, gearbox, differentials, etc. Maintenance of proper viscosity reduces the wear and tear of the component, it also increases the life of the component. During the maintenance of a vehicle the engine oil is drained even when the engine oil might be good condition. There is no proper system to monitor the engine oil. In order to eliminate such kind of draining of the engine oil, A System has been developed to monitor the oil quality which can be fixed in the vehicle and indicates the condition of the oil in dash board system by using InfraRed sensor coupled with color pigment sensor, so that the owner of the vehicle can easily know the condition of the engine oil and alarming the driver to change the oil. This engine oil condition monitoring system is named as "LUBSTER".

**Key Words:** Lubrication, Oil monitoring, Color pigment sensor, Infrared sensor

## 1. INTRODUCTION

India has one of the largest two and four wheeler markets in the world and every day, hundreds of people here buy a four wheelers (cars, truck etc)., As in this case with every machine, cars and heavy vehicles demand care and attention time to time in order to have proper functioning. The most common issue is that the parts in your engine will become too hot. This can cause the engine to run less efficiently, and as time goes on, it can cause the engine wear components to wrap and wear out and we know that lubricating oil plays major role in automobile industries it is the main property of good functioning of gears, engine components etc., it reduce the friction between tow parts and act as anticorrosion agent. After over usage of the oil it damages the internal components. So it is used with the combination of colour pigment sensor and turbidity sensor to determine the oil condition by sensing in the oil sump and indicates in the dash board .The indication is shown by the colour signals and it determines the condition of the oil and it will reminds to change the oil .it makes an awareness and helps to maintain the vehicle in good condition and smooth running of the vehicle. The Engine oil degrades in quality when it used for a period of time, so in order to find out its end period we have designed an instrument to find out. A turbidity sensor is used to determine the usage of the engine oil. A three-engine oil sample of 4T 10W30 is taken from starting of the engine oil and the second sample is taken at 2000 kms and third sample is taken at 3000 kms. This makes this instrument a convenient to measure the condition of the engine oil.

### 1.1 Definition

Lubricating oil can also be defined simply as lubricant/lube, is a class of oils used to reduce the friction, heat, and wear between mechanical components that are in contact with each other. The use of lubricating oils in vehicles is vital to their operation. When an engine is properly lubricated, it needs to put less work into moving pistons as the pistons glide easily. In the long run, this means that the car is able to operate while using less fuel and run at a lower temperature. Overall, the proper use of lubricating oil in a vehicle improves efficiency and reduces the amount of wear and tear on moving engine parts.

Turbidity is defined as the optical property that causes light to be scattered and absorbed rather than transmitted in straight lines through a sample. Models of light scattering can be divided into three domains based on a dimensionless size parameter,  $\alpha$  which is defined as

Where  $\pi D_p$  the circumference of the particle and  $\lambda$  is the wavelength of incident radiation. Based on the value of  $\alpha$ , these domains are:

$\alpha \ll 1$ : Raleigh scattering (small particle compared to wavelength of light)

$\alpha \approx 1$ : Mie scattering (particle about the same size as wavelength of light, valid only for spheres);

$\alpha \gg 1$ : geometric scattering (particle much larger than wavelength of light).

### 1.1.1 IR SENSOR

The wavelengths of these regions and their applications are shown below

- Near infrared region — 700 nm to 1400 nm —IR sensors, fiber optic
- Mid infrared region — 1400 nm to 3000 nm —Heat sensing
- Far infrared region — 3000 nm to 1 mm —Thermal imaging

For optical sensing and optical communication, photo optics technologies are used in the near infrared region as the light is less complex than RF when implemented as a source of signal. Optical wireless communication is done with IR data transmission for short range applications.

The basic concept of an Infrared Sensor which is used as Obstacle detector is to transmit an infrared signal, this infrared signal bounces from the surface of an object and the signal is received at the infrared receiver. There are five basic elements used in a typical infrared detection system: an infrared source, a transmission medium, optical component, infrared detectors or receivers and signal processing. Infrared lasers and Infrared LED's of specific wavelength can be used as infrared sources. The three main types of media used for infrared transmission are vacuum, atmosphere and optical fibers. Optical components are used to focus the infrared radiation or to limit the spectral response. Optical lenses made of Quartz, Germanium and Silicon are used to focus the infrared radiation. Infrared receivers can be photodiodes, phototransistors etc. some important specifications of infrared receivers are photosensitivity, detectivity and noise equivalent power. Signal processing is done by amplifiers as the output of infrared detector is very small.

### 1.1.2 TYPES OF IR SENSOR

Infrared sensors can be passive or active. Passive infrared sensors are basically Infrared detectors. Passive infrared sensors do not use any infrared source and detects energy emitted by obstacles in the field of view. They are of two types: quantum and thermal. Thermal infrared sensors use infrared energy as the source of heat and are independent of wavelength. Thermocouples, pyroelectric detectors and bolometers are the common types of thermal infrared detectors.

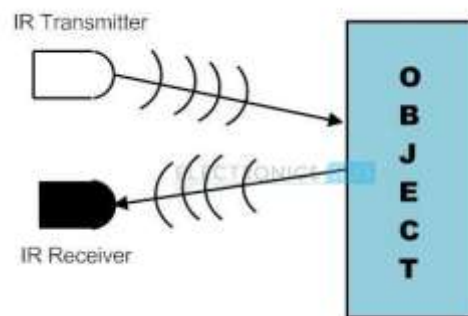

Fig:1.1.2

Quantum type infrared detectors offer higher detection performance and are faster than thermal type infrared detectors. The photosensitivity of quantum type detectors is wavelength dependent. Quantum type detectors are further classified into two types: intrinsic and extrinsic types. Intrinsic type quantum detectors are photoconductive cells and photovoltaic cells. Active infrared sensors consist of two elements: infrared source and infrared detector. Infrared sources include an LED or infrared laser diode. Infrared detectors include photodiodes or phototransistors. The energy emitted by the infrared source is reflected by an object and falls on the infrared detector.

The working of any Infrared sensor is governed by three laws: Planck's Radiation law, Stephen – Boltzmann law and Wien's Displacement law.

Planck's law states that "every object emits radiation at a temperature not equal to 00K". Stephen – Boltzmann law states that "at all wavelengths, the total energy emitted by a black body is proportional to the fourth power of the absolute temperature". According to Wien's Displacement law, "the radiation curve of a black body for different temperatures will reach its peak at a wavelength inversely proportional to the temperature".

1.1.3 A typical infrared receiver circuit using a phototransistor is shown below

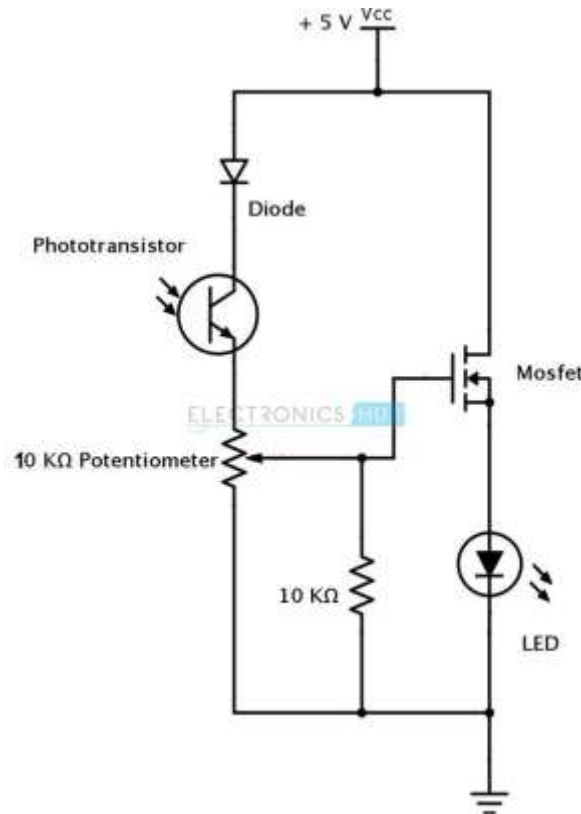

Fig:1.1.3

It consists of an IR phototransistor, a diode, a MOSFET, a potentiometer and an LED. When the phototransistor receives any infrared radiation, current flows through it and MOSFET turns on. This in turn lights up the LED which acts as a load. The potentiometer is used to control the sensitivity of the phototransistor.

2. LITERATURE REVIEW

**EXPERIMENTAL RESEARCH ON THE IMPACT OF LUBRICATING OILS ON ENGINE FRICTION AND VEHICLE FUEL ECONOMY.** Authors-Yimin Moa, Junping Wangb , Jun Wangc, Tuo Dongd and Wenjun Zhou: In this paper the lubricating oil co-relates to the friction of the engine.They have used some modifier to enhance the performance of engine oil.

**INVESTIGATING THE EFFECT OF ENGINE LUBRICANT VISCOSITY ON ENGINE FRICTION AND FUEL ECONOMY OF A DIESEL ENGINE.** Authors- Devendra Singh

They have tested the property of the engine oil with respect to temperature, speed and load. They also monitored the changes in lubrication changes in the engine.

**ENGINE OIL WEAR RESISTANCE.**

**Authors-**Masuhiko Kawamura, kenji fujita and kiyoshi Ninomiya The lubricating properties of the oil samples were tested based upon the type of fuel used in the engine.The load carrying condition were also tested.

**COMPARATIVE STUDY OF USED AND UNUSED ENGINE OIL (PEROQUA GENUINE AND CASTROL MAGNATEC OIL) BASED ON PROPERTY ANALYSIS BASIS.**

**Authors-** Syarifah Yunusa, Amirul Abd Rashida, Syazuan Abdul Latipa, Nik Rosli Abdullaha, Mohamad Ali Ahmada, Abdul Hakim Abdullaha. In this article they have tested two different types of lubricating oil based on kinematic viscosity.They also tested it upon wear element and changes in temperature condition.

**EFFECTS OF OIL PROPERTIES ON SPARK-IGNITION GASOLINE ENGINE FRICTION.**

**Authors-** MartinSkjoedt, RyanButts, Dennis N. Assanis, Stanislav V. Bohac. They tested the lubricating oil in the bases of friction,oil and viscosity grade based engine friction.They also analysed the difference in the synthetic and conventional oil based on viscosity grade.

**VISCOSITY SENSORS FOR ENGINE OIL CONDITION MONITORING APPLICATION AND INTERPRETATION OF RESULTS.**

**Authors-** A. Agoston a, C. Otsch a, B. Jakoby They monitored the thermal aging of lubricating oil. They have used micro-acoustic sensor and viscosity sensor.

**MONITORING OF THE PHYSICAL AND CHEMICAL PROPERTIES OF A GASOLINE ENGINE OIL DURING ITS USAGE .**

**Authors-**

Behnam Rahimi, Abolfazl Semnani, Alireza Nezamzadeh-Ejhi,Hamid Shakoori Langeroodi, andMassoud Hakim Davood.

They tested the lubricating oil based on flash point, viscosity index , specific gravity and density.They also monitored the contamination rate of the lubricating oil.

**DESIGN AND DEVELOPMENT OF LOW COST SMART TURBIDITY SENSOR FOR MONITORING WATER QUALITY IN FARMS.**

**Authors-** Lorena parra, javier rocher, Julia escriba,jaime lloret. In this paper we referred about the turbidity sensor and how it works and perform in checking the quality of the water .so we learned about the basic liquid condition

**DESIGN IS ABOUT CONTAMINANT SENSOR AND BASED ON THE NANO BIO SENSOR. Authors-**Niha mohan kulshreshtha, divya shrivatsava, prakash singh bisen. From this paper we just learned about the contamination sensor which Detects the particles and color change of a liquid.

**DEVELOPMENT OF AN INSTRUMENTATION SYSTEM FOR MEASURING OF DEGRADATION OF LUBRICATING OIL USING OPTICAL FIBER SENSOR. Authors-** S.Laskar, S.Bordoloi

In this paper we have learn that degradation of lubricating oil using optical sensor, how to monitor the oil condition.

**OPTICAL SYSTEM OF AUTOMATIC COLOUR MONITORING IN HETEROGENEOUS MEDIA DURING VINIFICATION PROCESSES. Authors-** Salvador Terrades , Simon Wagner , Jose Vicente.

In this paper we have learn about the colour pigment sensor.

**STUDY OF MICRO -STRUCTURAL , OPTICAL AND ELECTRICAL PROPERTIES OF TIO2 FILMS OBTAINED FROM MICRO CONTROLLER BASED SILAR METHOD. Authors-** Ashith V.K., Gowrish K.Rao Studied about the micro controller.**STABILIZED MICRO GRID USING ENHANCED ANFIS-PID WITH SVPWM CONTROLLER THROUGH HAPSO OPTIMISED SELECTIVE HARMONIC ELIMINATION. Authors-** Yuvaraj T , Ramya K, Gopinath M.

Studied about the PID with SVPWM.

**THERMAL ANALYSIS OF OIL SUMP Authors-**

hongyan shijianhua w

In this study, the temperature distribution, heat- transfer mechanism, and heat balance of the oil sump and compression.

**LUBRICATING OIL CONDITION SENSOR Authors-**

xiaoliang zhu,chong zhong.

Analysis of lubricating oil is an effective approach in judging machine's health condition and providing early warning of machine's failure

**ENGINE OIL WEAR RESISTANCE. Authors-** A.N. Farhanah, M.Z. Bahak

They tested the lubricating oil of SAE 10W30 with different temperatures of different manufacturers. They also tested the lubricating oil with different speed.

**THE LUBRICATING PROPERTIES OF USED ENGINE OIL.**

**Authors-** masuhiko kawamura, kenji fujita and kiyoshi ninomiya

The lubricating properties of the oil samples were tested based upon the type of fuel used in the engine. The load carrying condition were also tested.

**LOW-COST CONDITION MONITORING Authors-** surapol raadnuri

The sensor is designed as a direct measurement of the overall quality of the used oil as compare to that of the un-used oil. The system detects the relative variation of lubricant degradation .

**EFFECTS OF OIL PROPERTIES ON SPARK- IGNITION GASOLINE ENGINE FRICTION. Authors-** Martin Skjoedt, Ryan Butts, Dennis N. Assanis, Stanislav V. Bohac

They tested the lubricating oil in the bases of friction, oil and viscosity grade based engine friction. They also analysed the difference in the synthetic and conventional oil based on viscosity grade.

**3. WORKING PRINCIPLE**

The principle of an IR sensor working as an Object Detection Sensor can be explained using the following figure. An IR sensor consists of an IR LED and an IR Photodiode; together they are called as Photo – Coupler or Opto – Coupler.

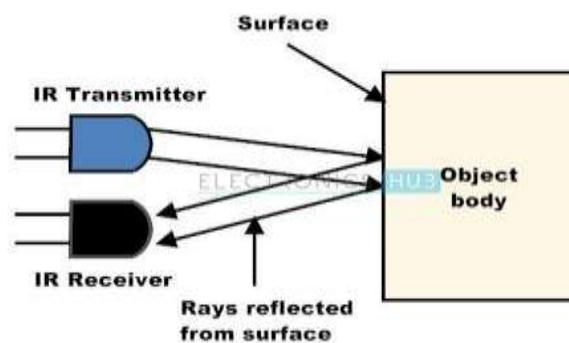

**Fig:3**

When the IR transmitter emits radiation, it reaches the object and some of the radiation reflects back to the IR receiver. Based on the intensity of the reception by the IR receiver, the output of the sensor is defined.

**3.1 OBSTACLE SENSING CIRCUIT OR IR SENSOR CIRCUIT**

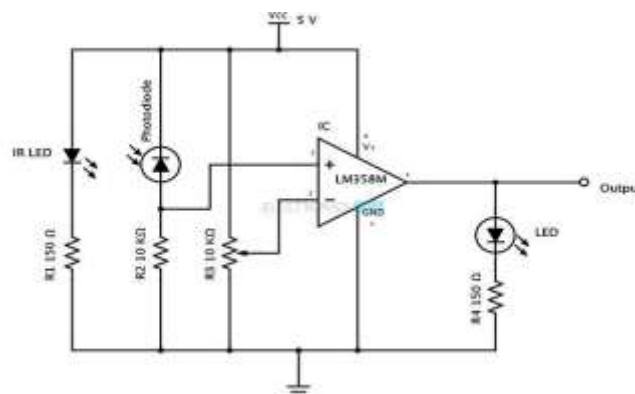

**Fig:3.1**

It consists of an IR LED, a photodiode, a potentiometer, an IC Operational amplifier and an LED.

IR LED emits infrared light. The Photodiode detects the infrared light. An IC Op – Amp is used as a voltage comparator. The potentiometer is used to calibrate the output of the sensor according to the requirement.

When the light emitted by the IR LED is incident on the photodiode after hitting an object, the resistance of the photodiode falls down from a huge value. One of the input of the op – amp is at threshold value set by the potentiometer.

The other input to the op-amp is from the photodiode’s series resistor. When the incident radiation is more on the photodiode, the voltage drop across the series resistor will be high. In the IC, both the threshold voltage and the voltage across the series resistor are compared. If the voltage across the resistor series to photodiode is greater than that of the threshold voltage, the output of the IC Op – Amp is high. As the output of the IC is connected to an LED, it lightens up. The threshold voltage can be adjusted by adjusting the potentiometer depending on the environmental conditions.

**3.2 Working Of LUBSTER (Engine oil condition monitor)**

The Engine oil degrades in quality when it used for a period of time, so in order to find out its end period we have designed an instrument to find out (Lubster).

An Infrared sensor is used to determine the usage of the engine oil.

A three-engine oil sample of 4T 10W30 is taken from starting of the engine oil and the second sample is taken at 2000 kms and third sample is taken at 3000 kms.

- An LCD display is used to indicate the condition of the engine oil like Pure for pure oil, Heavy for completely used bad oil and medium for partially used oil.
- This makes this instrument a convenient to measure the condition of the engine oil.
- The power supply is from the 12 v battery and is connected to the Arduino uno which is a microcontroller that acts as a ECU in cars which controls the sensors and other electronic components.

The Lubster will find whether the oil condition is good or bad by the coding feeded to the Arduino.

- The IR sensor senses the colloidal particles present in the engine oil by penetrating light via oil and receiver receives the signal and passes to the Arduino board.

The tested input signals of Various oil conditions are taken in account by IR sensor and we take the repeated values of results indicating the oil pure, medium or bad as finalized output.

The Lubster device is fixed in the drain cap of the sump and it senses the engine oil condition and the programming feeded to the Arduino board indicates whether the oil is good or bad in the dashboard of the vehicle.

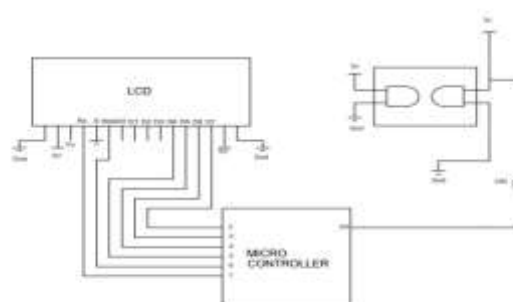

**Fig:3.1.1**

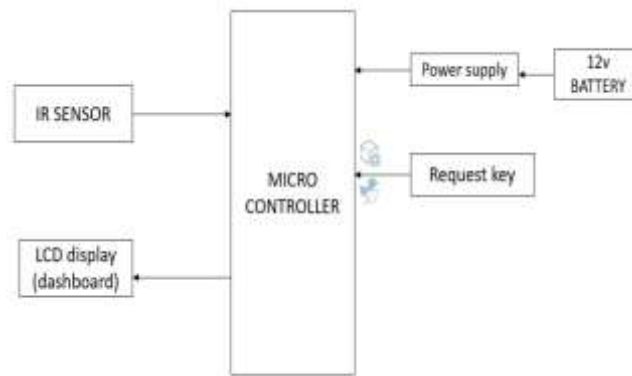

**Fig:3.1.2 Block Diagram of Oil condition monitoring system**

#### 4. ADVANTAGES OF LUBSTER

- We can use this device even as an equipment in service stations.
- Convenient method of identifying oil condition by the customers or users.
- We can fix this device in four wheelers and also with slight modification we can use it in two wheelers.
- The fixation of sensor is in drain can so that it can be easily repairable and replaceable.

#### 4.1 DISADVANTAGES OF LUBSTER

- Improper fixation of device after servicing can cause malfunction of the sensor.
- This device only indicates the property of the oil, the viscosity of the oil is not possible to find by this device.

#### 5. CONCLUSION

In this test analysis the Arduino is trained by using IR sensor which passes the light rays in the oil samples (normal, medium, heavy) oils and the oil is checked and noted for the exact values and accuracy by the test results taken by various conditions of oil in both dark and bright areas. The repeated values are taken as the best result and feed the values to the program. Thus the values helps in identifying the oil condition by the values noted by the Arduino. The light principles helps in check for the variations of values at different circumstances and regions. The values or displayed in the led display as numerical values to digital. This process helps to build the dash board indication that oil condition is good or bad and warning lights for changing the oil. It is easy to identify the condition of the engine oil by the users in a more convenient way.

#### 6. REFERENCES:

- [1] Sreten Perić<sup>1</sup>, Bogdan Nedić, Dragan Trifković<sup>1</sup>, and Mladen Vuruna<sup>1</sup>, 2013, An Experimental Study of the Tribological Characteristics of Engine and Gear Transmission Oils, *Strojnikivestnik - Journal of Mechanical Engineering* 59(2013)7-8, 443-450.
- [2] Yousef Alholli, Adel G alshammri, Ahmed I Abed, and Sobah Abdulrahman Alali, 2015, Mathematical Modeling of Engine New and Used Oils, *International Journal of Research in Advanced Engineering and Technology*, Volume: 1, Issue: 1, 16-19 Oct 2015.
- [3] Al-Araji, N. And Hussein, S., 2011. Effect of temperature on sliding wear mechanism under lubrication conditions. *International Journal of Engineering*, 5, 176-184.
- [4] ASTM D445-10. Standard test method for kinematic viscosity of transparent and opaque liquids (and calculation of dynamic viscosity).
- [5] Barton DB, Lowther HV, Rogers TW. Advantages of synthetic automotive lubricants. SAE Pap 1981;811413.
- [6] Black AL, Dunster RW, Sanders JV, mctaggart FK. Molybdenum disulphide deposits—their formation and characteristics on automotive engine parts. *Wear* 1967;10:17-32
- [7] D. Kornack and P. Rakic, "Cell Proliferation without Ne Saurabh, K., Mukherjee, P.S, 2005. Additives Depletion and Engine Oil Condition – A Case Study. *Industrial Lubrication and Tribology*, 57, p. 69-72.

- [8] Amit, K.S., Mukherjee, P.S, 2006. Interrelationship Among Viscosity, Temperature And Age Of Lubricant. *Industrial Lubrication and Tribology*, 58, p. 50-55.
- [9] Elvis, A., Shahrir, A., Kamal, A.A., Andanastuti, M., Khairuddin, 2009. Comparative Study of Characteristic of Lubricants Oils in Gasoline and Compressed Natural Gas
- [10] Nobuo Ushioda, Trevor W. Miller, Carrie B. Sims, et al. Effect of Low Viscosity Passenger Car Motor Oils on Fuel Economy Engine Tests, SAE Paper, 2013-01-2606, 2013.
- [11] Thomas tauber SAE technical paper series 1983. AIR 1828-a guide to gas turbine engine oil system monitoring.
- [12] Brij B.Seth SAE Technical Paper Series 1984.oil pressure signatures for engine lubrication system monitoring.
- [13] M.f.m Idros 2014 IEEE international conference on semiconductor electronics(ICSE2014)2014.condition based engine oil degradation monitoring system, synthesis and realizing on ASIC.
- [14] R.d.Somers IEEE conference on systems readiness technology, 'Advancing Mission Accomplishment'.
- [15] Bernardo tormos encyclopaedia of tribology 2013.engine condition monitoring based on oil analysis.