

# COMPARATIVE ANALYSIS FOR POWER QUALITY IMPROVEMENT OF CASCADED AND CAPACITOR CLAMPED MULTILEVEL INVERTER

Yadnesh V. Kingaonkar<sup>1</sup>, Amol B. Rane<sup>2</sup>, Dipak K. Warbhe<sup>3</sup>, Prakash P. Nakade<sup>4</sup>

<sup>1,2,3,4</sup>Students, Dept. of Department of Electrical Engineering, DMIETR, Wardha, Maharashtra, India

**Abstract** - The industrial revolution has been increased promptly at all over the world. With required suitable current, voltage and frequency for industrial purposes, multilevel inverter provides efficient power quality and continuous power supply for large industrial. Multilevel inverter is strongly known as an unconventional voltage medium, which converts DC power to AC power. However, the occurrence of harmonics would degrade the inferiority of the voltage produce by the inverter. This paper consists of comparative analysis of three phases Cascaded multilevel Inverter with Separate dc Source and Capacitor Clamped (Neutral Point Clamped) Inverter which eliminates the harmonics by two different levels. The switching technique used in this topology is sinusoidal pulse width modulation (SPWM). MATLAB/Simulink was used to generate the pulses to initiate harmonics. The percentage of harmonics produced will decrease in higher level. Three (3) and five (5) level was selected to simulate the circuit topology by using MATLAB software. The results obtain in this paper will be compared with respect to number of level, Total harmonic distortion and number of power semiconductor devices used.

**Key Words:** Fast Fourier Transform (FFT), Sinusoidal Pulse Width Modulation (SPWM), Total Harmonics Distortion (THD), Multilevel Inverter (MLI), Cascade H-Bridge (CHB).

## 1. INTRODUCTION

The power electronic device which has ability to convert the DC power into AC power is called as inverter. The inverters were used to drive mostly the lightening load When the grid gets off. But, nowadays due to increased advancement in technology inverters enhances their horizon of applications. Switch more DC to AC motor drives and uninterruptable AC power supplies where the objective is to produce a sinusoidal AC output whose magnitude and frequency can be controlled. Industrial applications of inverters for adjustable speed AC drives, HVAC transmission lines etc. DC power inputs that inverters can use are power supply network or rotating alternator through a rectifier, fuel cell, photovoltaic array. A power inverter or inverter, is a power electronic device or circuitry that changes direct current (DC) to alternating current (AC). The input voltage, output voltage frequency, and overall power handling depend on the design of the specific device or circuitry. The inverter does not produce any power; The power is provide

by the DC source. A power inverter can be entirely electronic or may be a combination of mechanical effects and electronic circuitry. Static inverters do not use moving parts in the conversion process. Power inverters are primarily used in electrical power applications where high currents and voltage are present.

In earlier days only two level inverter were used and produces the output with two different voltage levels but it has high switching losses and harmonic voltage causes the flow of the harmonic current in the circuit and produces the losses. So, to overcome the disadvantages certain advancement takes place in existing inverter such that levels can be increased more than two so that pure sinusoidal waveform is produced at the output voltage and harmonics in the output can be suppressed and percentage of losses can be decreased and this topology is named as multilevel inverter topology.

In this paper includes two topologies which are Cascaded H-bridge and Capacitor clamped (flying capacitor) multilevel inverter comparison of these two topologies. The switching technique used in this topology is sinusoidal pulse width modulation (SPWM). MATLAB/Simulink was used to generate the pulses to initiate harmonics. The percentage of harmonics produced will decrease in higher level. The operation of the proposed topology has been verified with computer simulation using MATLAB Simulink. These topologies were compared in terms of their merits and demerits, MATLAB simulation has been carried out for all three Topologies and compared with each other the number of power electronics components being utilized and the Total Harmonics Distortion. Fast Fourier Transform (FFT) analysis carry out. Comparison of this two topology was observed with respect to nature of voltage waveform and Total Harmonics Distortion was observer.

## 2. CASCADED MULTILEVEL INVERTER

The cascaded inverter uses series string of single phase inverter to construct the multilevel phase legs with separate DC sources. A single H-BRIDGE is a three level inverter. A single H-BRIDGE shown in fig. The CHB multilevel inverter requires a number of isolated dc supplies, each of which feeds an H-bridge power cell. For the seven- and nine-level inverters, 18- and 24-pulse diode rectifiers can be employed, respectively, to achieve low line-current harmonic distortion

and high input power factor. The output voltage of each H-BRIDGE can have three discrete level: +V<sub>dc</sub>, 0, -V<sub>dc</sub> which results into a staircase waveform. The four switches S<sub>1</sub>, S<sub>2</sub>, S<sub>3</sub> and S<sub>4</sub> are controlled to generate the three level output. In this Paper, the single-phase H-bridge power cell, which is the building block for the CHB inverter, is reviewed. A staircase modulation with selective harmonic elimination is also presented.

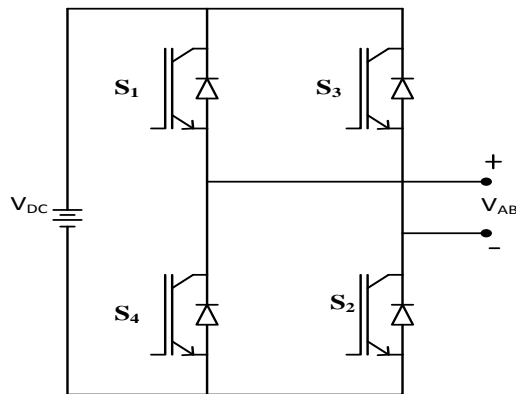

Fig. 1. 3-level cascaded H-Bridge multilevel inverter

TABLE 1. SWITCHING TABLE OF THREE LEVEL CASCADED-H BRIDGE INVERTER

Voltage	S1	S2	S3	S4
0	1	0	1	0
+V <sub>DC</sub>	1	1	0	0
-V <sub>DC</sub>	0	0	1	1
0	0	1	0	1

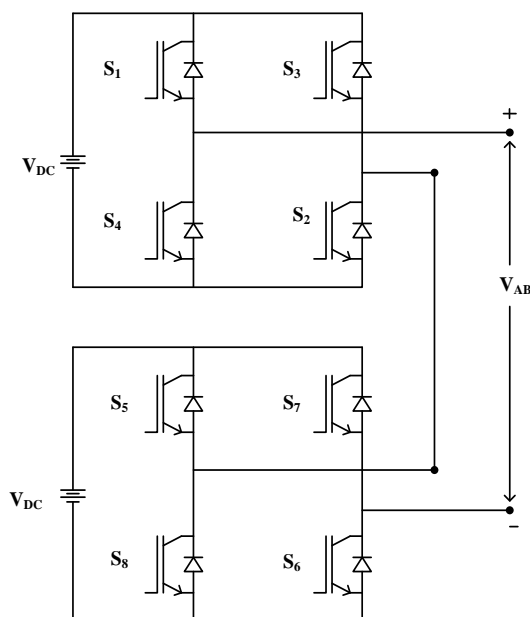

Fig. 2. 5-level cascaded H-Bridge multilevel inverter

TABLE 2. SWITCHING TABLE OF THREE LEVEL CASCADED-H BRIDGE INVERTER

voltage	S1	S2	S3	S4	S5	S6	S7	S8
0	0	1	0	1	1	0	1	0
V <sub>dc</sub>	1	0	0	1	0	1	0	1
2V <sub>dc</sub>	1	1	0	0	1	1	0	0
-V <sub>dc</sub>	0	1	0	1	1	0	0	1
-2V <sub>dc</sub>	0	0	1	1	0	0	1	1

### 3. CAPACITOR CLAMPED MULTILEVEL INVERTER

The main concept of this inverter is to use capacitors. It is of series connection of capacitor clamped switching cells. The capacitor transfer the limited amount of voltage to electrical devices. In this inverter switching state are like in the diode clamped inverter. It also has the switching redundancy within phase balance to flying capacitors. But due to high frequency switching, switching losses will takes place.

The topology consist of diodes, capacitors and switching devices. Although theoretically this topology has been designed to give infinite levels, but due to practical limitations this only give six level of voltage . Each leg consist of switching devices which are generally transistors. Capacitors nearer to the load have lower voltage. Capacitor nearer to the source voltage (V<sub>dc</sub>) have higher voltage. The number of level depends upon the number of conducting switches in each limb.

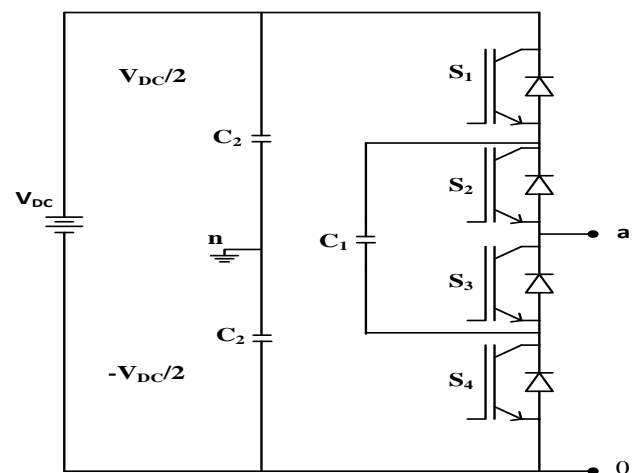

Fig 3. 3- Level Capacitor Clamped Multi level Inverter

TABLE 3. COMPARISION OF INVERTER ON THE BASIS OF POWER COMPONENTS

Inverter Configuration	Flying- capacitor	Cascade-inverter
Main switching device	2(m-1)	2(m-1)
Main diode	2(m-1)	2(m-1)
Clamping diode	0	0

DC bus capacitors	(m-1)	(m-1)/2
Balancing capacitors	(m-1)(m-2)/2	0

TABLE 4. APPLICATION OF DIFFERENT INVERTER

Cascade H-Bridge multilevel inverter	Flying Capacitor Multilevel Inverter
<ul style="list-style-type: none"> <li>Motor Drives</li> </ul>	<ul style="list-style-type: none"> <li>Induction Motor Using DTC</li> </ul>
<ul style="list-style-type: none"> <li>Active Filter</li> </ul>	<ul style="list-style-type: none"> <li>Static var generation</li> </ul>
<ul style="list-style-type: none"> <li>Electric Vehicle Drives</li> </ul>	<ul style="list-style-type: none"> <li>Both AC- DC And DC-AC Conversion Applications</li> </ul>
<ul style="list-style-type: none"> <li>DC Power Source Utilization</li> </ul>	<ul style="list-style-type: none"> <li>Converter With Harmonic Distortion Capability</li> </ul>
<ul style="list-style-type: none"> <li>Power Factor Compensators</li> </ul>	<ul style="list-style-type: none"> <li>Sinusoidal Current Rectifiers</li> </ul>

TABLE 5. ADVANTAGES AND DISADVANTAGES OF DIFFERENT INVERTERS

Advantages	Flying capacitor inverter	Cascade H-bridge inverter
	Low cost and less components due to less number of capacitors.	We get same switching frequencies for all the switches. Modular structure is easier to analyze.
Disadvantage	Pre-charging capacitors is difficult.	Separate DC sources are required.

TABLE 6. INPUT AND OUTPUT VOLTAGE OF INVERTER

Name Of Inverter	Input Voltage	Output Voltage Levels
Cascade H-Bridge Inverter	200V	+200V,+100V,0V. -100V,-200V
Flying Capacitor Inverter	200V	+100V,+50V,0V. -50V,-100V

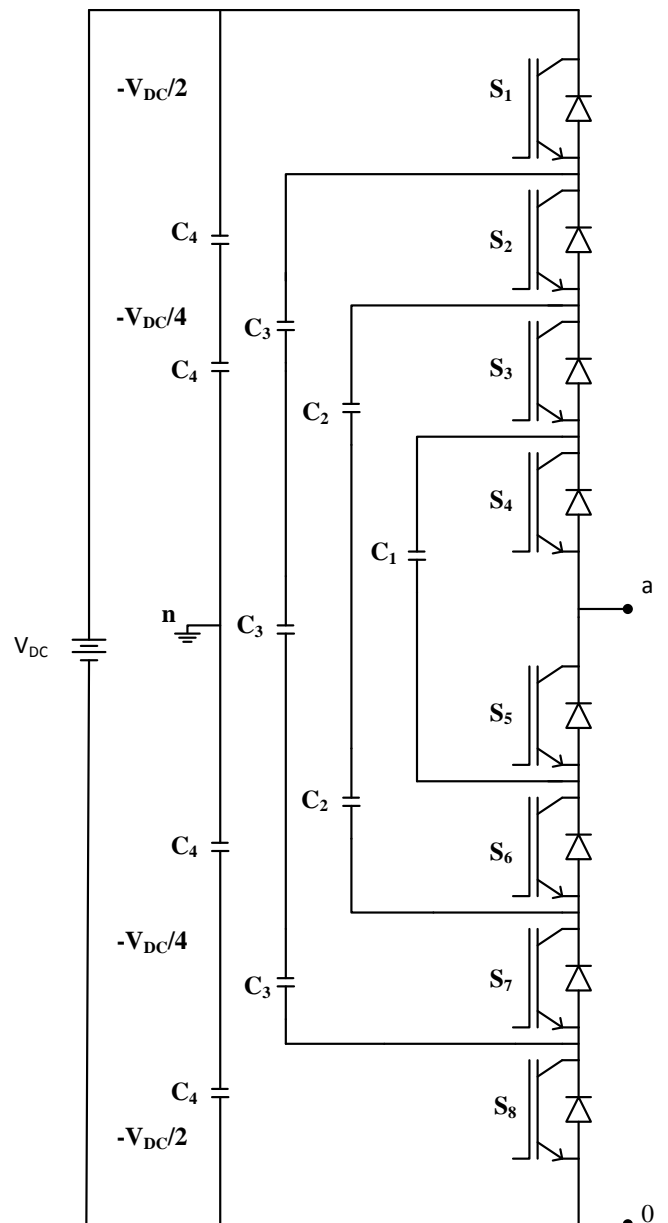

Fig 4. 5- Level Capacitor Clamped Multi level Inverter

#### 4. RESULTS AND DISCUSSION

In this section all obtained results discuss with step by step manner, where output voltage of cascaded and capacitor clamped inverter with their waveform and FFT shown.

##### A. RESULTS OF CASCADED MULTILEVEL INVERTER

As the Simulation is the done in MATLAB and output voltage waveform of the inverter obtained for three level and five level, also the nature of waveform as well as the level for phase voltage and line voltage for both level three and five was observed.

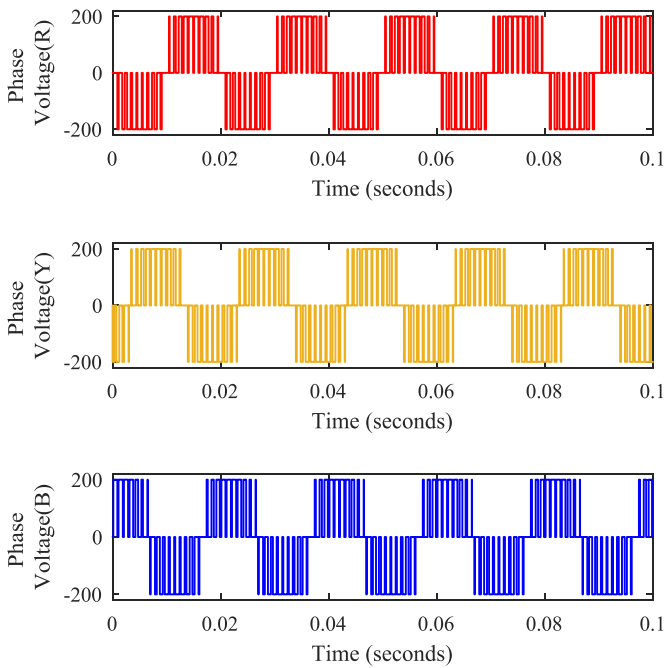

Fig.5. 3-Level Cascaded H-Bridge (Phase Voltage)

In above fig shown the output phase voltage waveform of cascaded multilevel inverter where it is clearly observing the three different level of output voltage -200V, 0V,+200V, where input voltage is 200V DC

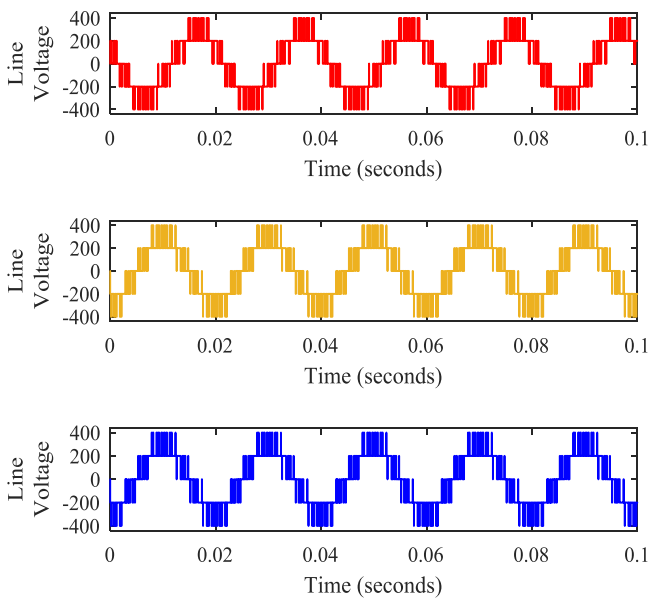

Fig.6. 3-Level Cascaded H-Bridge (Line Voltage)

In above fig shown the output phase voltage waveform of cascaded multilevel inverter where it is clearly observing the three different level of output voltage -400V, 0V, +400V, where input voltage is 200V DC

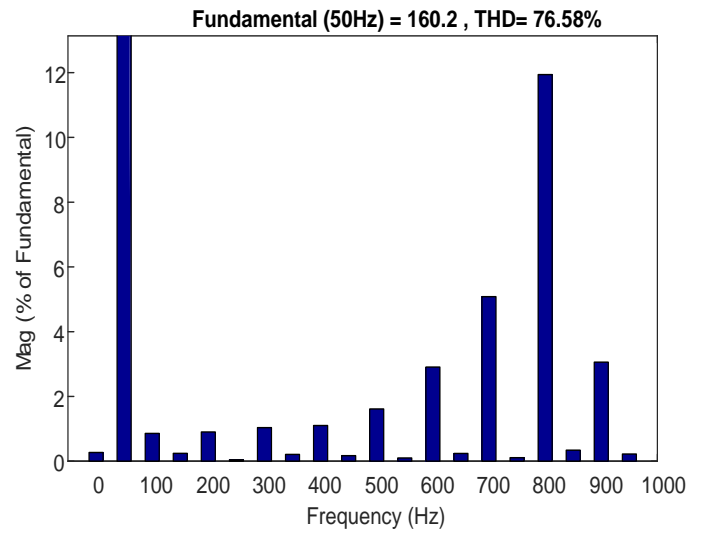

Fig.7. FFT Analysis of 3-Level Cascaded H-Bridge Inverter

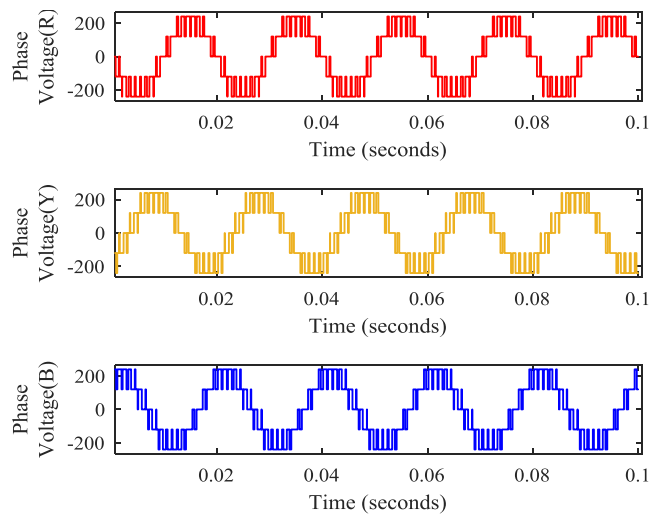

Fig.8. 5-Level Cascaded H-Bridge (Phase Voltage)

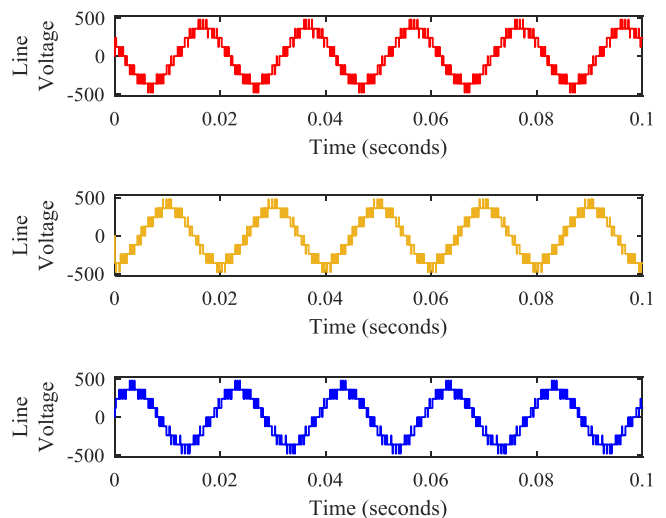

Fig.9. 5-Level Cascaded H-Bridge (Line Voltage)

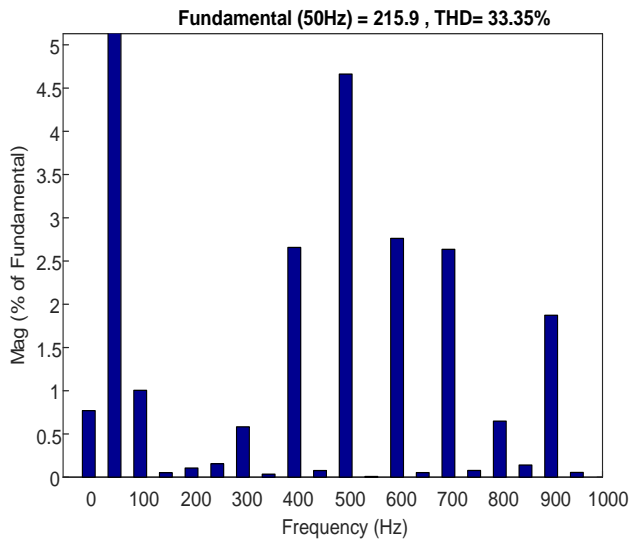

Fig.10. FFT Analysis of 5-Level Cascaded H-Bridge

As the fig. 6 shown the output line voltage waveform of 3-level inverter where we get 5 level for line voltage (-400V, -200V, 0V, +200V, +400V) and the Fig7 shows the FFT Analysis of 3-level cascaded H-Bride inverter where fundamental component is 160.2 and THD IS 76.58%. As the number of level increase the THD will reduced, which is clearly observable in the Fig10 which shows the FFT analysis for 5-level inverter having Fundamental component (50Hz) 215.9 and THD is 33.35%. Fig 8 shows the five level output phases voltage -200V, -100V, 0V, +100V, +200V.

**B. RESULTS OF CAPACITOR CLAMPED MULTILEVEL INVERTER**

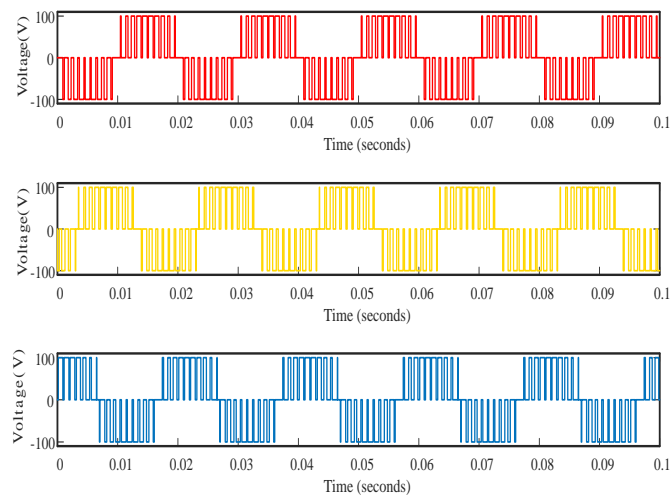

Fig.11. 3-Level Capacitor Clamped (Phase Voltage)

In above fig shown the output phase voltage waveform of capacitor clamped multilevel inverter where it is clearly observing the three different level of output voltage -100V, 0V, +100V, where input voltage is 200V DC

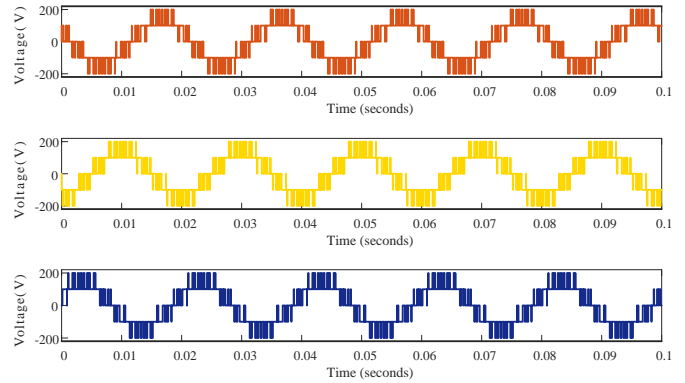

Fig.12. 3-Level Capacitor Clamped (Line Voltage)

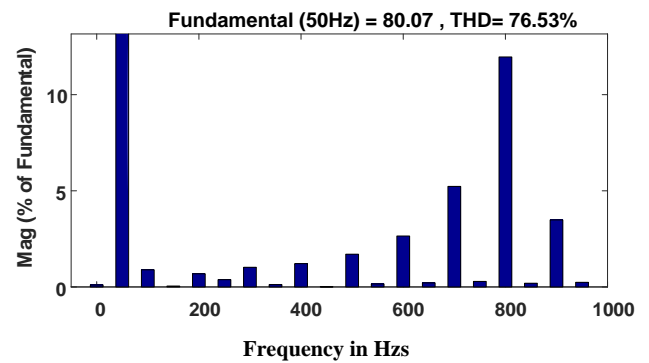

Fig.13. FFT Analysis of 3-Level Capacitor Clamped

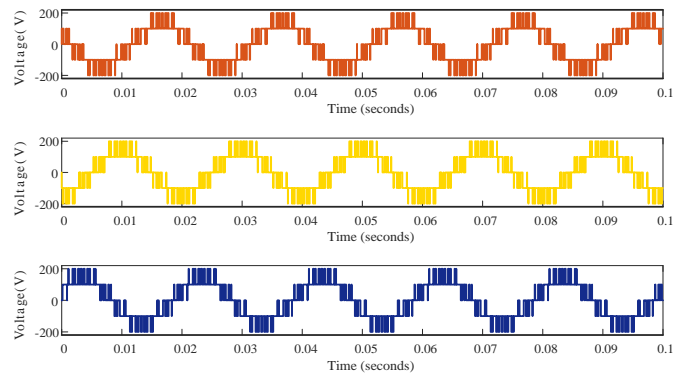

Fig.14. 5-Level Capacitor Clamped (Phase Voltage)

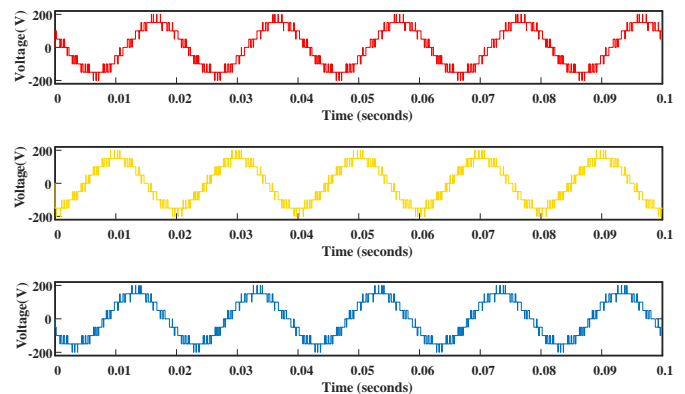

Fig.15. 5-Level Capacitor Clamped (Line Voltage)

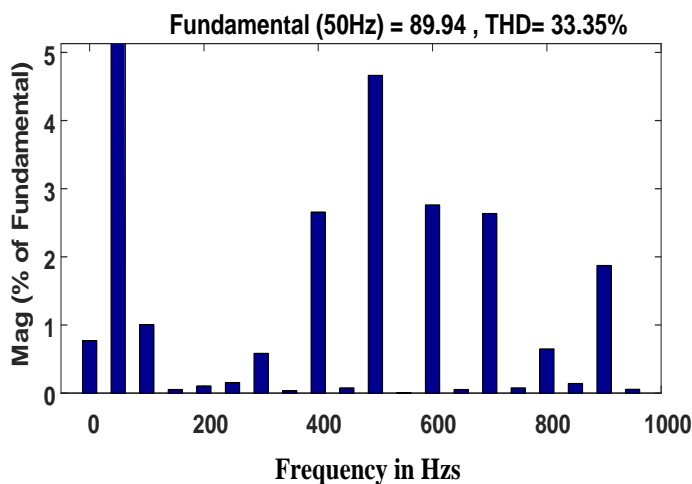

Fig.16. FFT Analysis of 5-Level Capacitor Clamped

## CONCLUSION

Two topologies (Cascaded and Capacitor Clamped) of three level and five level inverter are studied and simulated in MATLAB /Simulink. These topologies were compared in terms of their merits and demerits and the number of power electronic components beings utilized. Balancing of capacitor voltage is a primary issue in diode clamping topologies, But H-Bridge doesn't have above issue but it needs separate DC sources for each phase. Since the output voltage is twice compared to other two topologies, Cascaded H-Bridge can be very much useful for high power applications. With the increased level of output waveform THD decreased, filtering problem decreases. As the number of level increases the total harmonics distortion is decreases.

## REFERENCES

- [1] J. Rodriguez, Jih -Sheng Lai and Fang Zheng Peng, "Multilevel Inverters: A Survey of Topologies, Controls, and Applications", IEEE transactions on industrial electronics, vol. 49, no. 4, august 2002
- [2] M. P. Steimer and J. K. Steinke, "Five level GTO inverters for large induction motor drives," in Conf. Rec. IEEE-IAS Annu. Meeting, Oct.1993,
- [3] J. S. Lai and F. Z. Peng, "Multilevel converters—A new breed of power converters," IEEE Trans. Ind. Applicat., vol. 32, pp. 509–517, May/June 1996.
- [4] L. Tolbert, F.-Z. Peng, and T. Habetler, "Multilevel converters for large electric drives," IEEE Trans. Ind. Applicat., vol. 35, pp. 36–44, Jan./Feb.1999.
- [5] R. Teodorescu, F. Beaabjerg, J. K. Pedersen, E. Cengelci, S. Sulistijo, B. Woo, and P. Enjeti, "Multilevel converters — A survey," in Proc. European Power Electronics Conf. (EPE'99), Lausanne, Switzerland, 1999, CD-ROM.
- [6] A. Nabae, I. Takahashi, and H. Akagi, "A new neutral-point clamped PWM inverter," IEEE Trans. Ind. Applicat., vol. IA-17, pp. 518–523, Sept./Oct. 1981.

- [7] B. Urmila and D. Subbarayudu., "Multi level inverter: a comparative study of pulse width modulation techniques," International Journal of Scientific and Engineering research, Vol. 1, Issue. 3, pp. 2-5, 2010.
- [8] G. Prakash, B. M and U. S, "A New Multilevel Inverter with Reduced Number of Switches", International Journal of Power Electronics and Drive Systems (IJPEDS), vol. 5, no. 1, 2014.
- [9] W. McMurray, "Resonant snubbers with auxiliary switches," IEEE Trans. Ind. Applicat., vol. 29, pp. 355–362, Mar./Apr. 1993.
- [10] J. S. Lai and F. Z. Peng, "Multilevel converters—A new breed of power converters," IEEE Trans. Ind. Applicat., vol. 32, pp. 509–517, May/June1996.
- [11] K. A. Corzine, J. R. Baker, and J. Yuen, "Reduced parts-count multilevel rectifiers," in Conf. Rec. IEEE-IAS Annu. Meeting, Chicago, IL, Sept. 2001, CD-ROM.