

# Arduino based Single Phase Fault Detection System using IoT

Kanchan D. Sase

M.Tech Scholar, National Institute of Electronics & Information Technology (NIELIT), Aurangabad. Maharashtra.

**Abstract** - This Paper Deals with new method of single phase fault detection and also Auto switching based on arduino displayed over the internet. Our detection system deals with the current flowing through cables. Each cable will have its maximum current capacity. When short circuit fault occurs, current suddenly increases. Also in case of open circuit, current will be zero. Current transformers are used to detect current level, this output current will be given to I to V converter unit so as to make in readable in terms of voltage. This voltage is then fed to ADC pin of Arduino, which convert it into digital and take appropriate action if any fault condition (SC or OC) occurs. This fault is displayed on LCD display & on LEDs. Relay driver and relay circuit is used to switch single phase load of city electricity distribution system on other ok phase to provide end user an uninterrupted power supply. Fault clearing switch is provided for manually tell the system about fault clearing. Then only load will be switched to regular phase.

**Key Words:** Arduino UNO R3, LCD, Node MCU, IOT,

**Transformer**

## 1. INTRODUCTION

Power supply networks are growing continuously and their reliability getting more important than ever. The complexity of the whole network comprises numerous components that can fail and interrupt the power supply for end user. For most of the worldwide operated low voltage and medium voltage distribution lines, some faults are as follow,

### 1.1. Open Circuit Fault

Open circuit means the discontinuation of electron path or Open circuit fault is type of fault that occurs as opening in the circuit. In this type there is no current flow which can occurs as result of wire breakage. It means maximum resistance is present between two contacts.

### 1.2. Short Circuit Fault

When two conductors of a multi-core cable come in electrical contact with each other due to insulation failure, it is called short-circuit fault. a short circuit is type of current that result in over current flowing in circuit. In short circuited system the resistance of circuit reduced so excessive current to flow in the circuit.

### 1.3. Overload fault

Overload faults are the type of fault that device doing work more than rated capacity ,when this happens device or

machine will drawing current more than its rated capacity as a result device or machine may damaged ,this is overload fault.

## 2. LITERATURE SURVEY

This section provided the list of some significant works carried out by different investigators for cable fault detection. Sectionalizing is procedure reduces cable reliability, because it depends on physically cutting and splicing the cable. Dividing the cable into successively smaller sections and measuring both ways with an ohmmeter or high-voltage insulation resistance (IR) tester enable to narrow down search for a fault. This laborious procedure normally involves repeated cable excavation. Thumping is when high voltage is supplied to faulty cable; the resulted high current arc makes a noise loud enough to hear above ground. While this method eliminates the sectionalizing method's cutting and splicing, it has its own drawback. Thumping requires a current on the order of tens of thousands of amps at voltages as high as 25 kV to make an underground noise loud enough to hear above ground. The heating from this high current often causes some degradation of the cable insulation. The limit of damage can be reduced by passing minimum required power to conduct the test. The Time domain reflectometer (TDR) is an electronic instrument that uses time domain reflectometry to characterize and locate faults in metallic cables. The TDR sends a low energy signal through the cable, causing no insulation degradation. A theoretically perfect cable returns that signal in a known time and in a known profile. Impedance variations in a "real-world" cable alter both the time and profile, which the TDR screen or printout graphically represents. One weakness of TDR is that it does not pinpoint faults. Blavier Test is When a ground fault occurs in a single cable and there is no other cable, then blavier test can be performed to locate the fault in a single cable. In other words, in the absence of a sound cable to locate fault in the cable, then measurement of the resistance from one side or end is called blavier test. Ground fault of a single cable can be located using Blavier's test. In this kind of test, low voltage supply, an ammeter and voltmeter are used in a bridge network. Resistance between one end of the cable (Sending End) and earth is measured while "Far End" is isolated from the earth.

Arc Reflection Method is often referred to as a high voltage radar technique that overcomes the 200  $\Omega$  limitation of low-voltage radar. In addition to the TDR, an arc reflection filter and surge generator is required. The surge generator is used to create an arc across the shunt fault which creates a momentary short circuit that the TDR can display as a

downward-going reflection. The filter protects the TDR from the high voltage pulse generated by the surge generator and routes the low-voltage pulses down the cable. Arc reflection is the most accurate and easiest pre location method. The fault is displayed in relation to other cable landmarks such as splices, taps and transformers and no interpretation is required. Arc reflection makes it possible for the TDR to display “before” and “after” traces or cable signatures. The “before” trace is the low-voltage radar signature that shows all cable and marks but does not show the downward reflection of a high resistance shunt fault. The “after” trace is the high-voltage signature that includes the fault location even though its resistance may be higher than 200 Ω. This trace is digitized, stored and displayed on the screen and the cursors are positioned in order to read the distance to the high resistance fault.

### 3. System Description

The system deals with the current flowing through cables. Each cable will have its maximum current capacity. There are different types of fault occurs at cable like high voltage, low voltage, open circuited, short circuited. and our system is used to detect and auto correct fault using Arduino and system is operated using IOT and we can show fault on LCD display When short circuit fault occurs, current suddenly increases. Also in case of open circuit, current will be zero. This principle is used in our project and also high voltage and low voltage technique. Current transformers are used to detect fault of open circuit and close circuits using bulb. When fault is open circuited then then current is zero that is  $I=0$ . when current is short circuited then out Short circuit fault:- In this fault output voltage is zero but current is same. And also there are to detect high voltage and low voltage detection method .This project is to detect the of Single phase wire fault and also Auto switching based on arduino displayed over the internet. Our detection system deals with the current flowing through cables. Each cable will have its maximum current capacity. When short circuit fault occurs, current suddenly increases. Also in case of open circuit, current will be zero. This principle is used in our project. Current transformers are used to detect current level, this output current will be given to I to V converter unit so as to make in readable in terms of voltage. This voltage is then fed to ADC pin of Arduino, which convert it into digital and take appropriate action if any fault condition (SC or OC) occurs. This fault is displayed on LCD display & on LEDs. Relay driver and relay circuit is used to switch single phase load of city electricity distribution system on other ok phase to provide end user an uninterrupted power supply. Fault clearing switch is provided for manually tell the system about fault clearing. Then only load will be switched to regular phase.

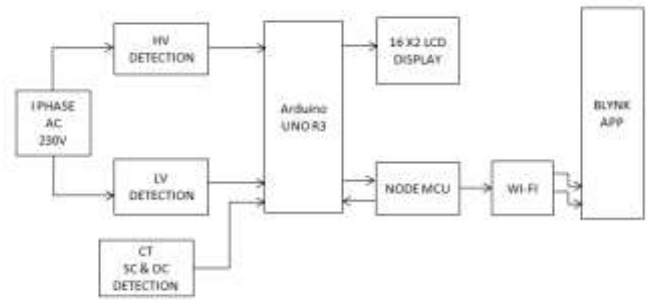

Fig-1: Block Diagram of System

### 4. COMPONENT

The elements have been selected due free hardware and software, and another, looks for functionalities that we pretend to give to the device. With these preambles, selected materials are listed below:

#### 4.1. Arduino UNO R3

Arduino Uno R3 is Microcontroller board based removable, dual in line package ATmega328 AVR microcontroller .It has 20 digital input/output pins (of which 6 can be used as PWM outputs, 6 analog inputs), a 16 MHz resonator, a USB connection, a power jack, an ICSP header, and a reset button. It contains everything needed to support the microcontroller; simply connect it to a computer with a USB cable or power it with an AC-to-DC adapter or battery to get started. This is third version of Uno (R3), which has a number of changes that is USB controller chip changed from ATmega8U2 (8k flash) to ATmega16U2 (16k flash) this does not increase the flash or RAM available to sketches, second is three pins were added, all of which are duplicates of previous pins. And the reset button is now next to the USB connector, making it more accessible when shield is used.

#### 4.2. Current transformer

The Current Transformer ( C.T. ), is a type of “instrument transformer” that is designed to produce an alternating current in its secondary winding which is proportional to the current being measured in its primary. *Current transformers* reduce high voltage currents to a much lower value and provide a convenient way of safely monitoring the actual electrical current flowing in an AC transmission line using a standard ammeter. The principal of operation of a basic current transformer is slightly different from that of an ordinary voltage transformer.

#### 4.3. ESP 8266

ESP8266 offers a complete and self-contained Wi-Fi networking solution, allowing it to either host the application or to offload all Wi-Fi networking functions from another application processor. When ESP8266 hosts the

application, and when it is the only application processor in the device, it is able to boot up directly from an external flash. It has integrated cache to improve the performance of the system in such applications, and to minimize the memory requirements.

#### 4.4. Node MCU

NodeMCU is a development board with the ESP8266 mounted on it. It also has a USB to Serial convertor chip on board. This removes the need of the FTDI USB to Serial Converter. Also, it has a voltage converter on board for converting the 5V supplied by the USB port to 3.3V input required by the ESP8266. So all you have to do is plug the USB cable from the computer right into the micro-usb slot of the Node MCU dev board, and you can start with your ESP8266 programming / prototyping right away. The Node MCU also provides many pins for use in your projects. It's just an easier way to program the ESP8266 module.

#### 4.5. 16X 2 LCD Modules

16 $\times$ 2 LCD is named so because; it has 16 Columns and 2 Rows. There are a lot of combinations available like, 8 $\times$ 2, 8 $\times$ 10 $\times$ 2, 16 $\times$ 2, etc. but the most used one is the 16 $\times$ 2 LCD. So, it will have (16 $\times$ 2=32) 32 characters in total and each character will be made of 5 $\times$ 8 Pixel Dots. Operating Voltage is 4.7V to 5.3V Current consumption is 1mA without backlight Alphanumeric LCD display module, meaning can display alphabets and numbers Consists of two rows and each row can print 16 characters. Each character is built by a 5 $\times$ 8 pixel box Can work on both 8-bit and 4-bit mode It can also display any custom generated characters Available in Green and Blue Backlight.

#### 4.6. ULN2003

The ULN2003 is a monolithic high voltage and high current Darlington transistor arrays. It consists of seven NPN Darlington pairs that feature high-voltage outputs with common-cathode Clamp diode for switching inductive loads. The collector-current rating of a single darlington pair is 500mA. The Darlington pairs may be paralleled for higher current capability. Applications include relay drivers, hammer drivers, lamp drivers, display drivers (LED gas discharge), line drivers, and logic buffers. The ULN2003 has a 2.7k $\Omega$  series base resistor for each darlington pair for operation directly with TTL or 5V CMOS devices.

### 5. CONCLUSIONS

In this project, the faults are detected Using Arduino Uno R3 and also message is displayed on LCD. There is one Arduino UnoR3 used to detect the fault like over current, high voltage, low voltage, also controller is used to switch the relays. Relays are used to operate supply to switch off all the loads in case of short circuit. When there is short circuit in the circuit then current transformer is used to detect and control the load

### 6. FUTURE SCOPE

In future following modifications can be done:

In next some years GSM service can be added in this system to know Consumer, when fault occurred.

The fault is automatically detected but by extending this we can automatically clear the fault in future.

In Future any fault occurs can be auto corrected. So accident occurs due to wire fault can be reduces.

### Acknowledgement

We are sincerely thankful to our institute National Institute of Electronics & Information Technology (NIELIT), Aurangabad. Maharashtra for providing us the world class infrastructure for the developing of the project. We are expressing our sincere thanks to our respected Executive Director Dr. Sanjeev Kumar Gupta and Scientist A.K. Joshi for permitting us to present this paper and also to Scientist Saurabh Bansod for their continuous encouragement, suggestions and support during the tenure of the paper & research work. We hereby also acknowledge the literature which helped us directly or indirectly in the preparation of this paper & research work.

### REFERENCES

- [1] Zoolnasri Bin Abu Harun, University Malaysia Pahang, "Over Current Protection Relay Using PIC Micro Controller", Project report. PP 1-24
- [2] "Microcontroller based fault detection", International Journal of Advancements in Research & Technology, Volume 1, Issue 5, October-2012 1 ISSN 2278-7763
- [3] Fault detection and protection of induction motors using sensors", 2008, Ramazan Bayindir, Ibrahim Sefa, İlhami Colak, and Askin Bektas
- [4] M. E. H. Benbouzid, "Bibliography on induction motors faults detection and diagnosis," IEEE Trans. Energy Convers., vol. 14, no. 4, pp. 1065-1074, Dec. 1999.
- [5] Anderson PM. Analysis of faulted power systems. New York (USA): IEEE; 1995.
- [6] "INDUCTION MOTORS - PROTECTION and STARTING by VIV COHEN" Circuit Breaker Industries, P.O. Box 881, Johannesburg 2000, South Africa.
- [7] Muhammad Ali Mazidi, Rolin D. McKinlay, Danny Causey "PIC Microcontroller and Embedded system using Assembly and C for PIC18".

**BIOGRAPHIES**

Ms. Kanchan D. Sase Completed Graduation From PES College of Engineering ,Aurangabad In The Year 2011 and Pursuing For The Post Graduation In Electronics Design And Technique From National Institute Of Electronics And Information Technology (NIELIT), Aurangabad