

Introduction of STATCOM in PV grid system

Arti Pandey¹, Bhupendra singh Niranjana², Chandra Shekhar Azad³, Umesh Maurya⁴

¹Assistant Professor, Dept. of EEE, MGIMT, Lucknow, UP, India

²Assistant Professor, Dept. of EEE, MGIMT, Lucknow, UP, India

³Associate Professor, Dept. of EEE, MGIMT, Lucknow, UP, India

⁴UG Scholar, Dept. of EEE, MGIMT, Lucknow, UP, India

Abstract – Due to fast reduction of conventional energy, the power demand escalating every passing day. This paper focuses on the photo voltaic (PV) system integrated to a three phase four wire system at the distribution level with power quality improvement features. The power quality measurements and the norms followed according to the guiding principle specified in the International Electro technical Commission standard, IEC61400 are the active and reactive power variations, variation of voltages, flicker, harmonics and electrical behavior of switching operations. The paper describes overall good functional characteristics, better performance and faster response than existing systems. The proposed system of having STATCOM is smaller in size and less costly when compared to the existing system.

Key Words: PV Grid, STATCOM, Power Quality Measurement, power quality etc.

1. INTRODUCTION

Power is the very essential input for the growth of any economy. Therefore, it is considered as a core industry as it facilitates development across a variety of sectors, such as agriculture, manufacturing, railways, education, commercial etc. to expel economic development. To meet the high GDP rates the energy needs of the country are unavoidable. To have sustainable growth and social evolution, it is necessary to meet the energy demand by utilizing the non-conventional energy resources like wind, biomass, hydro, co-generation, etc. The need to incorporate the renewable energy like wind energy into power system is to make it possible to reduce the environmental impact on conventional plants [1].

The integration of wind energy into on hand electrical power system induces power quality problems like voltage regulation, stability, harmonic distortion, voltage sag/swell and poor power factor. The power quality is primarily customer-focused measure and is significantly affected by the operation of a distribution and transmission network. In this proposed scheme one of the Flexible AC transmission system (FACTS) device i.e., STATCOM is connected at point of common coupling (PCC) with a battery energy storage system (BESS) to mitigate power quality problems. Since, STATCOM connected to the grid provides reactive power support to wind generator as well as to loads. The BESS is integrated to sustain real power source under changeable wind or solar power.

In the event of sudden load change or change in voltage profile during short circuit at point of common coupling STATCOM responds fast and stabilises the voltage and also helps to maintain power quality norms during such sudden and unexpected challenges.

This proposed PV cell STATCOM control scheme for grid connected wind energy generation for power quality improvement has following objectives.

- Unity power factor at the source side.
- Reactive power support only from STATCOM to wind Generator and Load.
- Simple bang-bang controller for STATCOM to achieve fast dynamic response.

1.1 Problems related to power quality:

Utility should make sure that the power matches the customer requirements and should not violate the limits that are specified for the parameters which define the power quality. From the customer point of view the voltage variations and large amount of harmonics in the grid power are extremely undesired as they affect the performance of the end equipments. For the IIP's who have planned the wind power project, the voltage profile of evacuating substation and nearby substations is of prime concern.

1.1.1 Voltage variation:

Discontinuous nature of wind power causes numerous problems and one is variation of voltage of buses in the region of high RE penetration. Wind generators generally employed induction generators and power electronic circuits which requires reactive power for operation. Voltage sag/swell is observed where unproductive methods of reactive power management are employed. If voltage increases beyond the controllable limit, forced tripping of lines carried out, cascaded tripping may strike at the foundations of a weak power system. Generally the power factor of evacuating substation is maintained near to unity preferably slightly lagging.

1.1.2 Voltage Transient:

Fault in the power system network, capacitor switching and HVDC systems are the main cause of voltage transients. Voltage transients are responded well by STATCOM.

1.2 Power quality issues:

In wind energy generating system the power quality primarily concerned with the quality of current waveform which is being drawn or generated by the wind turbine. Poor power quality affects the performance of the loads connected to the grid.

1.2.1 Reactive Power Consumption:

Induction generators draw reactive power to produce its working flux while generate active power at the same time. As induction generators are most widely preferred in wind turbine generators, collectively a wind farm demand huge amount of reactive power.

As the wind speed is not constant, the use of electronic power conversion devices in wind turbine generators becomes inevitable to achieve a rotor speed for maximum extraction of energy from wind. The operation of power electronic devices also requires reactive power. To avoid voltage stability problem either STATCOM or capacitor arrangement is used to supply this demand of reactive power.

1.2.2 Current Harmonics Generation:

Capacitors are used as an essential part of the wind turbine generators for supplying reactive power demand. Capacitor switching may cause large voltage transient. The frequency and amplitude of such transient are enormous, particularly when back to back switching is involved, for instance capacitor bank switching. The over voltages may damage the insulation, Moreover, electronic equipments such as controllers are very sensitive to these transients, may produce incorrect commands. In addition, lightning strikes will cause an over voltage in the electrical system of wind turbine.

2. TOPOLOGY FOR POWER QUALITY IMPROVEMENT:

The PV cell STATCOM based current control voltage source inverter injects the current into the grid in such a way that the source current are harmonic free and their phase-angle with respect to source voltage has a desired value. The injected current will cancel out the reactive part and harmonic part of the load and induction generator current, thus it improves the power factor and the power quality. To accomplish these goals, the grid voltages are sensed and are synchronized in generating the current command for the inverter. The proposed grid connected system is implemented for power quality improvement at point of common coupling (PCC), as shown in Figure 1. The grid connected system in Fig. 1, consists of wind energy

generation system and battery energy storage system with PV cell and Statcom.

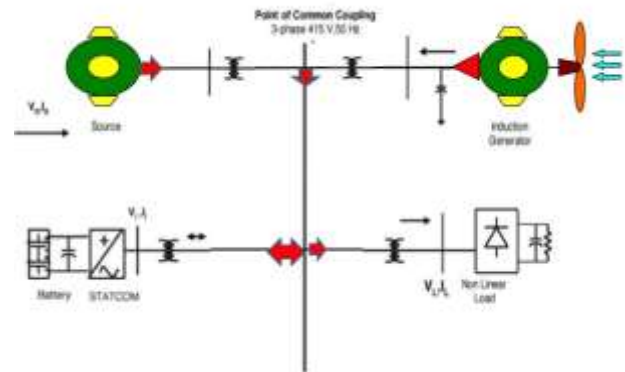

Figure 1: Grid Connected system for Power Quality improvement

2.1 Static Synchronous Compensator (STATCOM):

A Static Synchronous Compensator (STATCOM) also known as Static Synchronous Condenser. STATCOM is a regulating device used on alternating current (AC) electricity transmission network. It is based on power electronic voltage source or sink of reactive AC power to an electricity network. STATCOM is shunt connected compensation device having the ability of injecting or absorbing the reactive power.

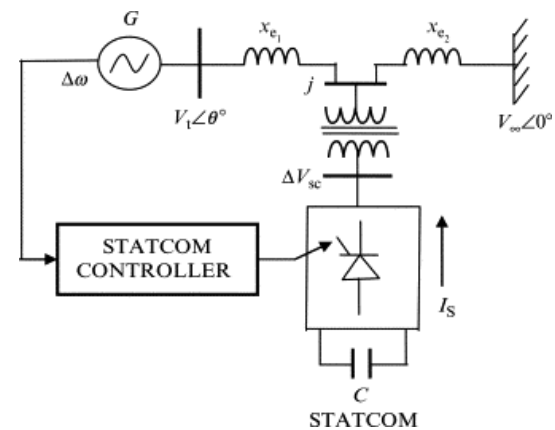

Figure 2: Circuit Diagram of STATCOM

2.2 BESS-STATCOM:

The battery energy storage system (BESS) is used as an energy storage element to support the wind farm during intermittencies it also support grid during any disturbance and loss of generation. The BESS will naturally maintain dc capacitor voltage constant and is best suited in STATCOM since it readily manages demand and supply of real power and also injects or absorbed reactive power to stabilize the grid system. It also controls the distribution and transmission system at a very fast rate. When power fluctuations occur in the system, the BESS can be used to

level the power fluctuations by charging and discharging operation. The BESS system is connected in parallel to the dc capacitor of STATCOM [2]–[6].

The applications of the BESS-STATCOM are as following,

- Power quality improvement
- Load shifting
- Peak power shaving
- Uninterrupted power supply
- Intermittency mitigation
- Frequency regulation

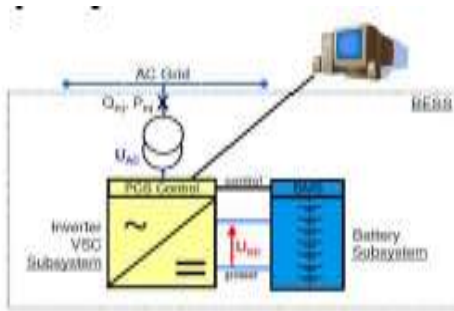

Figure 3: Battery Energy Storage System

STATCOM comes from the family of FACTS devices. These are basically solid-state devices which are having the capability to respond to the reactive power demand. STATCOM have the edge over the SVC's as the former have constant current characteristics while in the SVC's the capacitive current drops linearly with the voltage. STATCOM can easily be interfaced with real power sources like the battery systems, fuel cells etc. STATCOM effectively control the system voltage and avoid voltage collapse. [8]

STATCOM are solid state shunt connected devices. STATCOM's strategically placed in the power system to make the grid robust to the disturbances. STATCOM are finding applications in the renewable energy integration.

2.3 System operation:

In the system under study STATCOM is interfaced with the BESS system. The STATCOM-BESS system is then connected to the PCC in the grid where non-linear loads and induction generator based wind turbine are also interfaced. Current control strategy is adopted to control the STATCOM –BESS system. The control strategy controls the output of STATCOM in such a manner so as to achieve power quality norms in the electrical grid. The STATCOM is intended here to support both reactive as well as real power demand of the other sub-systems. [7]

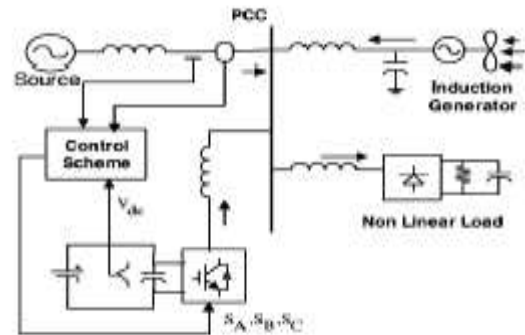

Figure 4: System Operation

3. Control scheme:

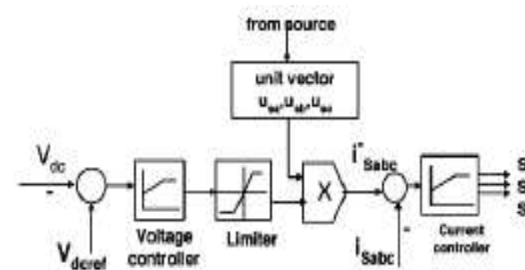

Figure 5: Control System Scheme

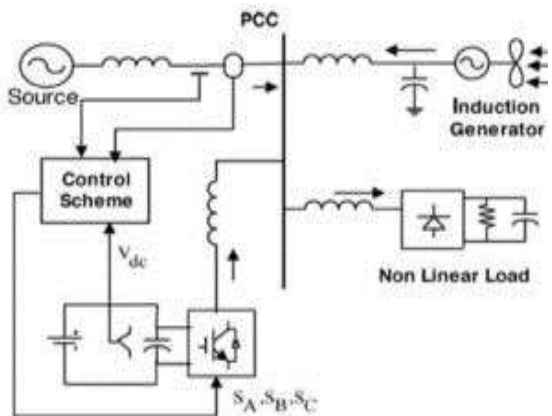

Figure 6: Statcom Operation in Power System

The charged capacitor C dc provides a DC voltage, U_{dc} to the converter, which produces a set of controllable three-phase output voltages, U_{in} in synchronism with the AC system. The synchronism of the three-phase output voltage with the transmission line voltage has to be performed by an external controller. The amount of desired voltage across STATCOM, which is the voltage reference, U_{REF} , is set manually to the controller. The voltage control is thereby to match U_T with U_{REF} which has been elaborated. This matching of voltages is done by varying the amplitude of the output voltage U , which is done by the firing angle set by the controller. The controller thus sets U_T equivalent to the U_{REF} .

The control scheme approach is based on injecting the currents into the grid using “bang-bang controller.” The controller uses a hysteresis current controlled technique. Using such technique, the controller keeps the control system variable between boundaries of hysteresis area and gives correct switching signals for STATCOM operation.

3.1 Bang-Bang Current Controller:

In control theory, a bang-bang controller (on-off controller), also known as a hysteresis controller, is a feedback controller that switches quickly between two states. These controllers may be realized in terms of any element that provides hysteresis. They are often used to control a plant that accepts a binary input, for example a furnace that is either completely on or completely off. Most common residential thermostats are bang-bang controllers. The Heaviside step function in its discrete form is an example of a bang-bang control signal. Due to the discontinuous control signal, systems that include bang-bang controllers are variable structure systems, and bang-bang controllers are thus variable structure controllers.

Thus the ON/OFF switching signals for IGBT of STATCOM are derived from hysteresis controller.

3.2 Voltage Source Current Control:

The three phase injected current into the grid from

STATCOM will cancel out the distortion caused by the nonlinear load and wind generator. The IGBT based three-phase inverter is connected to grid through the transformer. The generation of switching signals from reference current is simulated within hysteresis band of 0.08. The choice of narrow hysteresis band switching in the system improves the current quality.

The choice of the current band depends on the operating voltage and the interfacing transformer impedance. The compensated current for the nonlinear load and demanded reactive power is provided by the inverter.

4. CONCLUSION

The paper presents the STATCOM-based control scheme for power quality improvement in grid connected system and with non linear load. The power quality disturbances and its consequences on the consumer and electric utility are presented. It has a capability to cancel out the harmonics parts of the load current. It maintains the source voltage and current in phase and support the reactive power demand, thus it gives an opportunity to enhance the utilization factor of a transmission line. Thus the proposed scheme in the grid connected system fulfills the power quality norms as per the IEC standard 61400-21.

5. REFERENCES

- [1] A. Sannino, “Global power systems for sustainable development”, in IEEE General Meeting, Denver, CO, Jun. 2004.
- [2] Z. M. Salamah, M. A. Casacca, and W. A. Lynch, “A mathematical model for lead-acid batteries,” IEEE Trans. Energy Conversion, vol. 7, no. 1, pp. 93–97, Mar. 1992.
- [3] Z. Yang, C. Shen, L. Zhang, M. L. Crow, and S. Atcitty, “Integration of a STATCOM and battery energy storage,” IEEE Trans. Power Syst., vol. 16, no. 2, pp. 254–260, May 2001.
- [4] M. Black and G. Strbac, “Value of bulk energy storage for managing wind power fluctuations,” IEEE Trans. Energy Conversion, vol. 22, no. 1, pp. 197–205, Mar. 2007.
- [5] E. Spahic, G. Balzer, and A. D. Shakib, “The impact of the ‘wind farm battery’ unit on the power system stability and control,” in Proc. IEEE Power Tech., Lausanne, Jul. 2007, pp. 485–490.
- [6] S. W. Mohod and M. V. Aware, “Grid power quality with variable speed wind energy conversion,” in Proc. IEEE Int. Conf. Power Electronic Drives and Energy System (PEDES), Delhi, Dec. 2006.
- [7] C. Han, A. Q. Huang, M. Baran, S. Bhattacharya, and W. Litzemberger, “STATCOM impact study on the integration of a large wind farm into a weak loop power system,” IEEE Trans. Energy Conv., vol. 23, no. 1, pp. 226–232, Mar. 2008.
- [8] R. S. Bhatia, S. P. Jain, D. K. Jain, and B. Singh, “Battery energy storage system for power conditioning of renewable energy sources,” in Proc. Int. Conf. Power Electron Drives System, Jan. 2006, vol. 1, pp. 501–506.
- [9] Ganesh.Harimanikyam1, S.V.R. Lakshmi Kumari2 “Power Quality Improvement of Grid Connected Wind Energy System by Statcom for Balanced and Unbalanced Linear and Nonlinear LoadsGa” International Journal of Engineering Research and Development, Volume 3, Issue 1 (August 2012), PP. 09-17.
- [10] K. Sheshu Kumar, K. Suresh Kumar, SkBaji “A New Control Scheme for Power Quality Improvement with STATCOM” IJERA Vol. 3, Issue 4, Jul-Aug 2013, pp.2555-2561.
- [11] P. Ramanathan “A Statcom-Control Scheme for Grid Connected Wind Energy System for Power Quality Improvement” Middle-East Journal of Scientific Research, 57-61, 2014.
- [12] Yuvaraj,Dr.S.N.Deepa N.D. (2011), “Improving grid power quality with FACTS device on integration of wind energy system”, student pulse, april 2011, vol.3, issue 4, www.studentpulse.com